

Product Description:

- Metal casing, 3m or 4m laser BGS diffuse reflection detection distance.
- Suitable for automotive manufacturing, metallurgical industry, non-standard equipment, textile machinery, etc

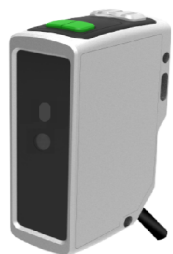

Product features:

- BGS function greatly improves detection performance
- Long detection distance
- Adjust sensitivity by adjusting the knob
- IP67 protection rating
- Relay output mode

Type	Distance	light source	Output	Connection	Wiring
OSM70-AKL3000VR5 *M ¹⁾	0.1m...3m	Infrared VCSEL	Relay	Cable	Fig.1
OSM70-AKL4000VR5 *M ¹⁾	0.1m...4m	Infrared VCSEL	Relay	Cable	Fig.2

Note 1): * M refers to the cable length in meters. If there is no * M in the model, the default cable length is 2 meters.

TECHNICAL SPECIFICATION

OPERATING VOLTAGE	24...240 V DC ±10% 24...240 V AC ±10% 50/60Hz	AMBIENT TEMPERATURE OPERATION	-25°C...+55°C
DETECTION LIGHT SOURCE	Infrared VCSEL Laser(940nm)	AMBIENT TEMPERATURE STORAGE	-40°C...+70°C
INDICATOR LIGHT SOURCE	Red Laser(655nm)	CIRCUIT PROTECTION	Short-circuit protection, Reverse polarity protection
OUTPUT CHARACTERISTICS	Relay Output:1c Contact 250 V AC 3A(cosφ=1)below	PROTECTION DEGREE	IP67
CONSUMPTION CURRENT	≤55mA	HOUSING	Die-Casting Zinc
REPEATABILITY	20mm	CONNECTING TYPE	Cable
POWER INDICATION	Green LED	RESPONSE FREQUENCY	20-50Hz
OUTPUT INDICATION	Yellow LED		

DIMENSIONS

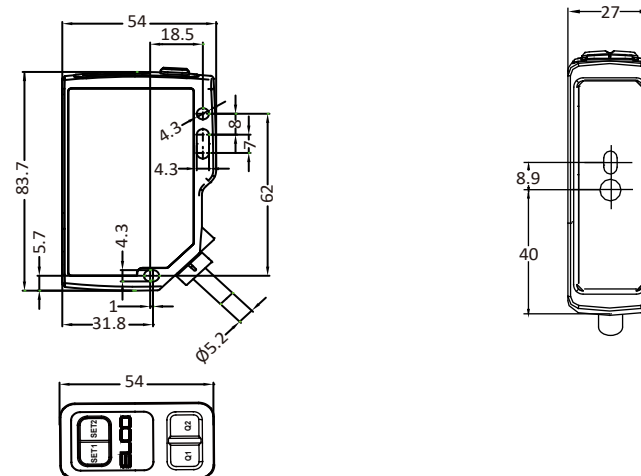

INDICATORS

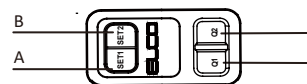

A	SET1		
B	SET2		
C	Power indicator	Green	
D	Output indicator	Yellow	

ELECTRICAL CONNECTION

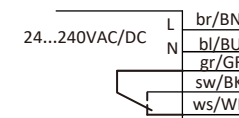

Fig.1

ELSAFETY WARINGS

- Safety warning

All the safety electrical and mechanical regulations and laws have to be respected during sensor operation. The sensor has to be protected against mechanical damages. Do not look directly into the laser beam! Do not point the laser beam towards people!

- Installation Tips

Please keep the window clean to ensure the accuracy of measurement.

Before setting the mode, please ensure that the detection objects are placed correctly.

If Q1 flickers once and Q2 flickers continuously after setting, it means that there is an error in setting please reset the Settings according to the operation method after Q2 flicker stops.

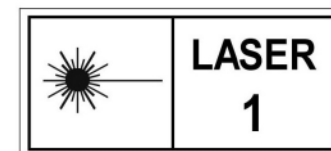

IEC 60825-1:2014
EN 60825-1:2014+A11:2021

MODE SETTING: use in the background suppression mode, please refer to the following installation and operation method

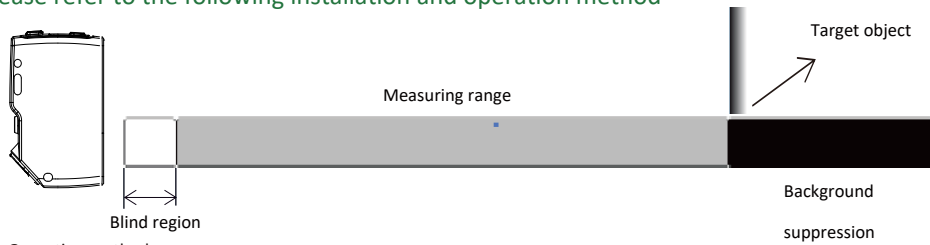

Operation method

Prior to entering the teaching mode, the buttons did not work.

● Mode1:Background suppression mode settings

1.1 At the same time press SET1 and SET2 more than 2s, Q1 and Q2 flashes at the same time, you can lift the button.

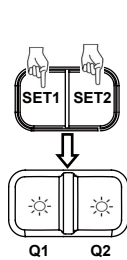

1.2 Verify that the target test object is placed in the desired location.

①

1.3 Press SET1, Q1 off, Q2 LED flashes one time. Entering the selection state of background suppression threshold.

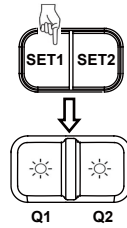

1.4 Press SET2 to select the distance value at this time. Wait Q1 flashes once, it means that the setting is successful, the setting mode of background suppression and the teaching mode is withdrawn. If there is no operation within 1 minutes, the teaching mode will be withdrawn.

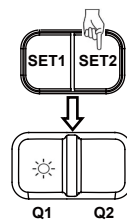

MODE SETTING: use in the foreground suppression mode, please refer to the following installation and operation method

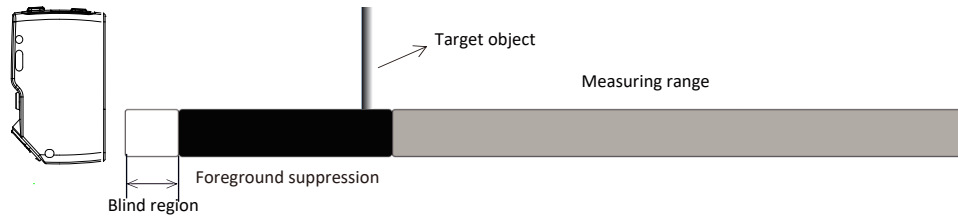

Operation method

Prior to entering the teaching mode, the buttons did not work.

● Mode2:suppression suppression mode settings

2.1 At the same time press SET1 and SET2 more than 2s, Q1 and Q2 flashes at the same time, you can lift the button.

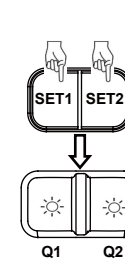

2.2 Verify that the target test object is placed in the desired location.

②

2.3 Press SET1 twice continuously Q2 flashes twice, and enter the foreground suppression value selection state.

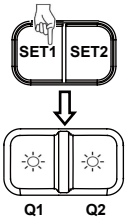

2.4 Press SET2 to select the distance value at this time. Wait Q1 flashes once, it means that the setting is successful, the setting mode of foreground suppression and the teaching mode is withdrawn. If there is no operation within 1 minutes, the teaching mode will be withdrawn.

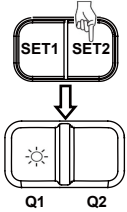

MODE SETTING: use in the window operation mode, please refer to the following installation and operation method

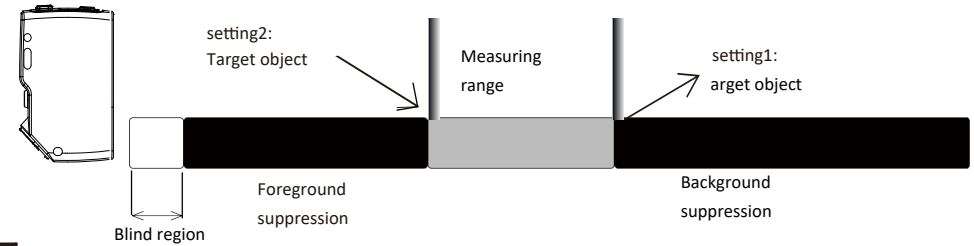

Operation method

Prior to entering the teaching mode, the buttons did not work.

● Mode 3:Window operating mode settings

3.1 At the same time press SET1 and SET2 more than 2s, Q1 and Q2 flashes at the same time, you can lift the button.

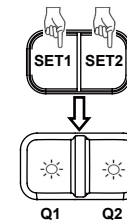

3.2 Verify that the target test object is placed at the setting1 location.

3.3 Three continuous press SET1, Q1 off, Q2 flashes three times threshold state. and enter the window

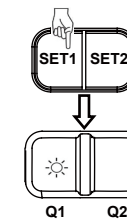

③

3.4 Press SET2 to select the distance value as the maximum value. Wait Q1 flashes once, it means that the setting is successful. If there is no operation within 1 minutes, the teaching mode will be withdrawn.

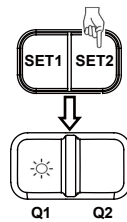

3.5 Verify that the target test object is placed at the setting 2 location.

3.6 Press SET2 to select the distance value as the minimum value. Wait Q1 flashes once, it means that the setting is successful, the setting mode of window operation and the teaching mode is withdrawn. If there is no operation within 1 minutes, the teaching mode will be withdrawn.

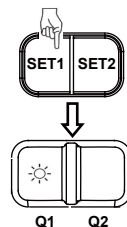

产品说明:

- 金属外壳, 3m/4m激光BGS漫反射检测距离。
- 适用于汽车制造、冶金行业、非标设备、纺织机械等应用

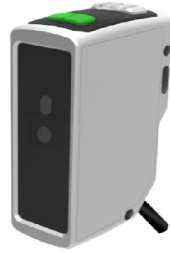

产品特点:

- BGS功能极大提升检测效果
- 检测距离长
- 通过按键调节灵敏度
- IP67防护等级
- 继电器输出

型号	检测距离	光源	输出方式	连接方式	接线图
OSM70-AKL3000VR5 *M ¹⁾	0.1m...3m	红外激光Class I	继电器	线缆	图1
OSM70-AKL4000VR5 *M ¹⁾	0.1m...4m	红外激光Class I	继电器	线缆	图1

注1): *M表示线缆长度, 单位米, 型号中无*M默认线缆长度为2米。

技术参数

工作电压	24...240 V DC ±10% 24...240 V AC ±10% 50/60Hz	工作环境温度	-25°C...+55°C
检测光源	红外VCSEL光源 (940nm)	储存环境温度	-40°C...+70°C
指示光源	红光激光(655nm)	保护电路	短路保护 反极性保护
输出特性	继电器输出: 1c触点 250 V AC 3A(cosφ=1)以下	防护等级	IP67
消耗电流	≤55mA	外壳	压铸件
重复精度	20mm	连接方式	线缆式
电源指示灯	绿色LED	响应频率	20-50Hz
输出状态指示灯	红色LED		

外形尺寸

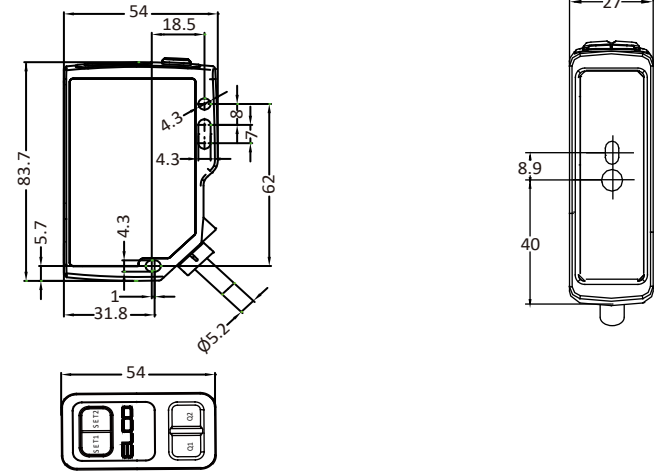

操作指示

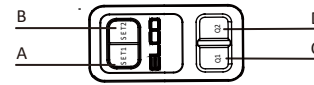

A	设置1	
B	设置2	
C	电源指示灯	绿色
D	输出状态指示灯	黄色

接线图



图1

安全警示

所有传感器功能必须符合电子和机械安全规定的法律法规
禁止直视激光束;
禁止把激光指向人;

请保持窗口面清洁, 以保证测量精度

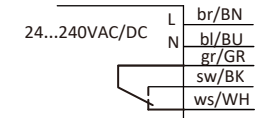
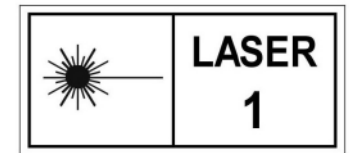

IEC 60825-1:2014
EN 60825-1:2014+A11:2021

模式设置：使用在背景抑制模式时，请参看以下安装及操作方法

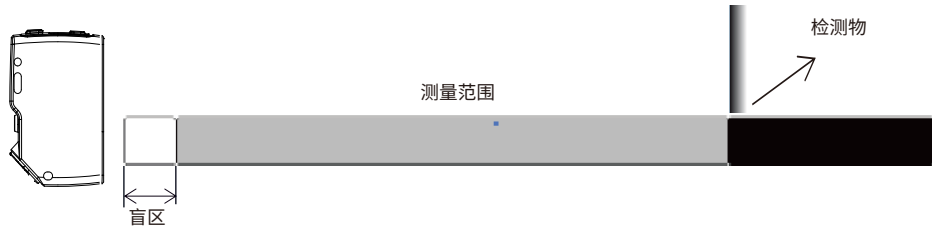

操作方法

在进入示教模式之前，按键不起作用

● 模式1：背景抑制模式设定

1.1同时按下SET1和SET2大于2s，Q1、Q2同时闪烁，即可抬起按键

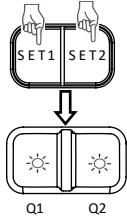

1.2确认目标测试物放置到所需位置

①

1.3按下SET1，Q1熄灭，Q2单次频闪，进入背景抑制阈值选取状态

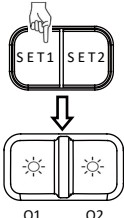

1.4 按下SET2，选取此时距离值，等待Q1闪烁一次，即设置成功，退出背景抑制设置模式，同时退出示教模式。如果1分钟内未进行操作，则退出示教模式。

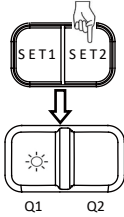

模式设置：使用在前景抑制模式时，请参看以下安装及操作方法

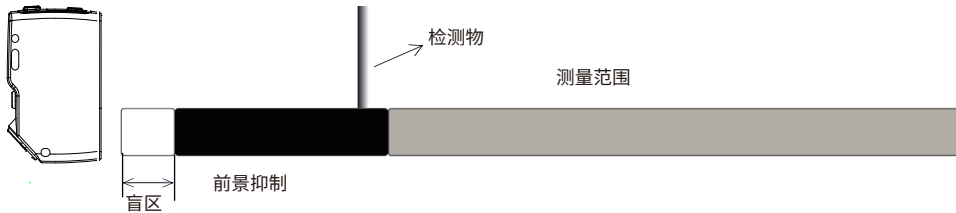

操作方法

在进入示教模式之前，按键不起作用

● 模式2：前景抑制模式设定

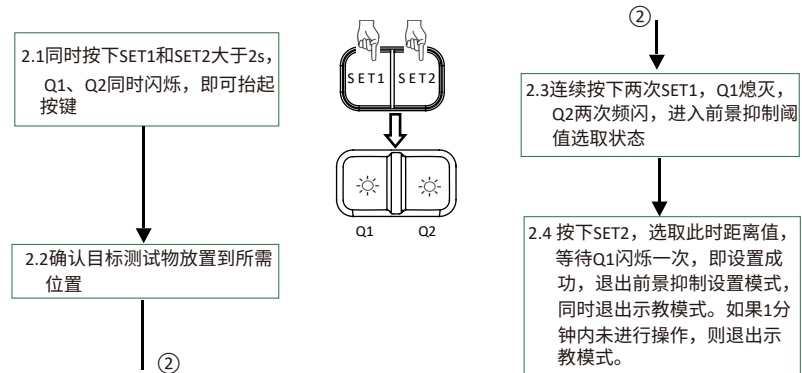

模式设置：使用在窗口模式时，请参看以下安装及操作方法

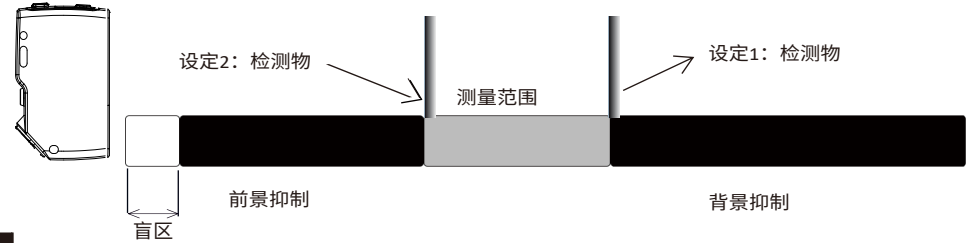

操作方法

在进入示教模式之前，按键不起作用

● 模式3：窗口模式设定

3.1同时按下SET1和SET2大于2s，Q1、Q2同时闪烁，即可抬起按键

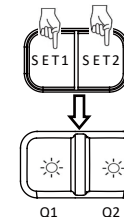

3.2确认目标测试物放置到设定1的位置

3.3连续按下三次SET1，Q1熄灭，Q2三次频闪，进入窗口阈值选取状态

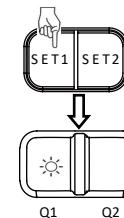

3.4 按下SET2，选取此时距离值作为最大值，等待Q1闪烁一次，即设置成功。如果1分钟内未进行操作，则退出示教模式。

3.5确认目标检测物防止到设定2的位置

3.6 按下SET2，选取此时距离值作为最小值，等待Q1闪烁一次，即设置成功，退出窗口设置模式，如果1分钟内未进行操作则退出示教模式。

