

Product Description

- Laser displacement sensor ,655nm laser source,FULL Metal JACKET,durable,better protective performance,small light spot,high precision,LED display and key setting,displacement ranging from 50 mm to 400 mm center point. Suitable for dispensing machine,packing,automobile AGV and other industries.



Product features:

- Short,medium and long distances are available.
- Support switch output,NPN/PNP can be set.
- Support analog output,current output/voltage output can be set.
- Support laser light source control through external input.
- Support ECO mode setting.
- Four white digital tubes,clear and bright
- Strong ambient light resistance and compact size
- Support multiple detection modes,multi-scene applications.



Type	Measurement range	Measurement center distance	Beam diameter	Repeatability	Linearity	Resolution
OSM41-KL30CBLIU6*M	25...35mm	30mm	0.2mm @50mm	10μm	±0.1%F.S.	0.001mm
OSM41-KL30CBLIU6-*-Q12.1						
OSM41-KL50CBLIU6*M	35...65mm	50mm	0.5mm @50mm	30μm	±0.1%F.S.	0.01mm
OSM41-KL50CBLIU6-*-Q12.1						
OSM41-KL100CBLIU6*M	65...135mm	100mm	0.5mm @100mm	70μm	±0.1%F.S.	0.01mm
OSM41-KL100CBLIU6-*-Q12.1						
OSM41-KL200CBLIU6*M	120...280mm	200mm	1mm @200mm	200μm	±0.2%F.S.	0.1mm
OSM41-KL200CBLIU6-*-Q12.1						
OSM41-KL400CBLIU6*M	200...600mm	400mm	1mm @150mm 2mm @600mm	0.5mm(≤400mm) 1mm(≤600mm)	±0.2%F.S.(≤400mm) ±0.3%F.S.(≤600mm)	0.1mm
OSM41-KL400CBLIU6-*-Q12.1						
OSM41-KL1500CBLIU6*M	150...1500mm	400mm	1mm @150mm 2mm @600mm	0.3mm (200mm~400mm)	±0.2%F.S. (200mm~400mm) ±0.3%F.S. (400mm~600mm) ±0.5%F.S. (600mm~1500mm)	1mm
OSM41-KL1500CBLIU6-*-Q12.1				2mm (600mm~800mm) 5mm (800mm~1500mm)		

Note 1: This product is a laser product, which can be used after 10 minutes of preheating after power-on.

Note 2: For breakout products, *M represents the cable length; if not specified, the default is 2 meters.

For pigtail products, * represents the cable length in meters. If there is no Wei connector product

We reserve the right to make technical alterations without prior notice. | EN & CN | Creation date: 25.12.04 | UM_SP_OSM41-LIU_V1.0_EN&CN

TECHNICAL SPECIFICATION

OPERATING VOLTAGE	10...30 V DC , Class 2	WORKING TEMPERATURE	-10°C ... +50°C
POWER SUPPLY	<1W	AMBIENT ILLUMINANCE	Under 3000lux
LIGHT SOURCE TYPE	Laser class 2, 655nm	PROTECTION DEGREE	IP67
CONTROL OUTPUT	NPN/PNP can be set	HOUSING MATERIAL	Die-cast zinc
ANALOG OUTPUT	Current : 4~20mA (beyond,0mA) Voltage : 0~5V (beyond,5.2V) 0~10V (beyond,10.2V)	WINDOWS MATERIAL	Glass
		CONNECTIONS	Cable/Pigtail Cable
		RESPONSE TIME	15ms/5ms/1.5ms
		LASER LABEL	pasting on packing bag
		MAINTAIN	disassemble; please return to ELCO
		MAXIMUM HUMIDITY	Max.85%Rh
		ALTITUDE	Up to 2000m
		POLLUTION DEGREE	3



DIMENSIONS

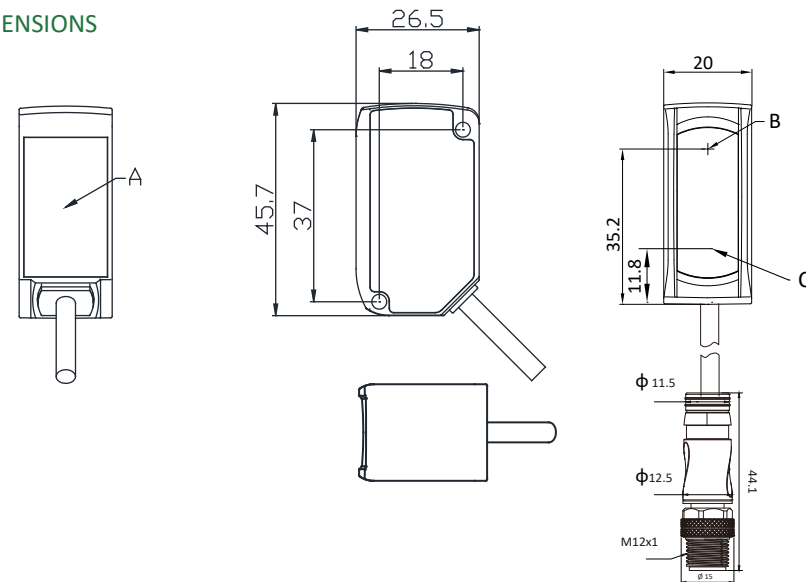

A:Button
B:Transmitter
C:Receiver

产品说明:

- 激光位移传感器, 655nm激光光源, 全金属外壳, 坚固耐用, 防护性能更好, 体积小, 光斑小, 精度高, LED显示和按键设置, 50mm~400mm中心点的位移型测距。适用点胶机、包装、汽车、AGV等行业应用。

产品特点:

- 短、中、长三种检测距离可选
- 支持开关量输出, NPN/PNP可设定
- 支持模拟量输出, 电流输出/电压输出可设定
- 支持激光光源通过外部输入控制
- 支持ECO模式设定
- 四位白色数码管, 明亮清晰
- 抗环境光能力强, 紧凑尺寸
- 支持多种检测模式, 多场景应用



型号	检测距离	测量中心距离	光束直径	重复精度	线性度	分辨率
OSM41-KL30CBLIU6*M	25...35mm	30mm	0.2mm@50mm	10μm	±0.1%F.S.	0.001mm
OSM41-KL30CBLIU6-0.3-Q12.1						
OSM41-KL50CBLIU6*M	35...65mm	50mm	0.5mm@50mm	30μm	±0.1%F.S.	0.01mm
OSM41-KL50CBLIU6-0.3-Q12.1						
OSM41-KL100CBLIU6*M	65...135mm	100mm	0.5mm@100mm	70μm	±0.1%F.S.	0.01mm
OSM41-KL100CBLIU6-0.3-Q12.1						
OSM41-KL200CBLIU6*M	120...280mm	200mm	1mm@200mm	200μm	±0.2%F.S.	0.1mm
OSM41-KL200CBLIU6-0.3-Q12.1						
OSM41-KL400CBLIU6*M	200...600mm	400mm	1mm@150mm 2mm@600mm	0.5mm(≤400mm) 1mm(≤600mm)	±0.2%F.S.(≤400mm) ±0.3%F.S.(≤600mm)	0.1mm
OSM41-KL400CBLIU6-0.3-Q12.1						
OSM41-KL1500CBLIU6*M	150...1500mm	400mm	1mm@150mm 2mm@600mm	0.3mm(200mm~400mm) 0.8mm(400mm~600mm) 2mm(600mm~800mm) 5mm(800mm~1500mm)	±0.2%F.S.(200mm~400mm) ±0.3%F.S.(400mm~600mm) ±0.5%F.S.(600mm~1500mm)	1mm
OSM41-KL1500CBLIU6-0.3-Q12.1						

注1: 本产品为激光类产品, 上电预热十分钟后使用。

注2: 出线产品*M代表线长, 如无为默认2M长度。pigtail产品*代表线长, 单位为米, 若无为接插件产品。

技术参数

工作电压	10...30VDC, Class2	工作温度	-10°C...+50°C
功率	<1W	环境照度	3000lux以下
光源	激光 II 级, 655nm	防护等级	IP67
控制输出	NPN/PNP可选	外壳	压铸锌
模拟量输出	电流: 4~20mA(超出时, 0mA) 电压: 0-5V(超出时, 5.2V) 0-10V(超出时, 10.2V)	窗口	玻璃
		连接形式	线缆式/pigtail线缆
		反应时间	15ms/5ms/1.5ms可选
		激光标签	包装袋粘贴
		维护信息	异常返厂宜科处理
		最高湿度	最高85%相对湿度
		海拔	高达2000米
		污染程度	三级

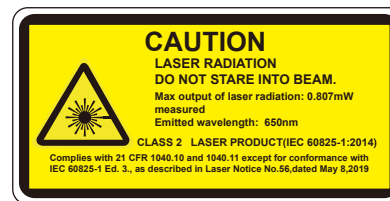

外型尺寸

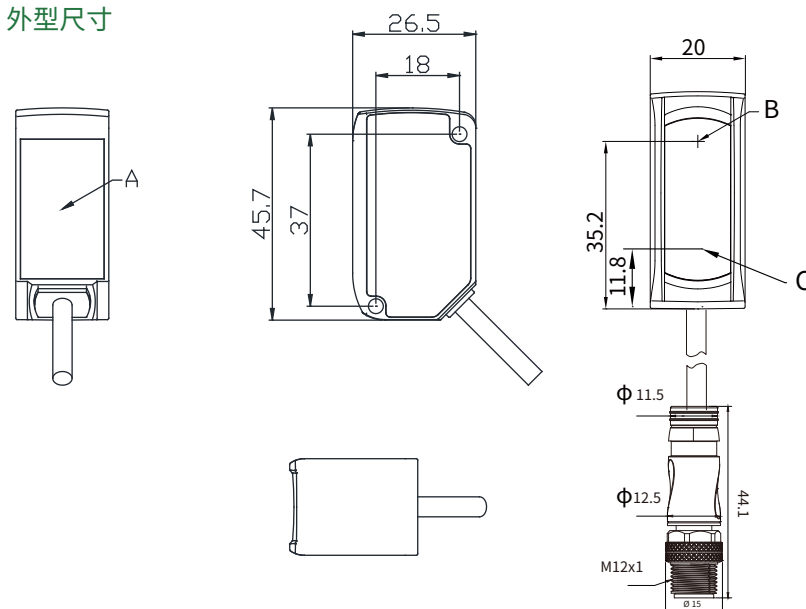

A: 按键
B: 发射端
C: 接收端

INTERFACE DEFINITION AND WIRING DIAGRAM

	Function	Cabel product core color
1	Positive power supply	Brown
2	Analog output	Gray
3	Power negative	Blue
4	NPN/PNP	Black
5	External input/set to 0	Pink
6	AGND	Shielded wire

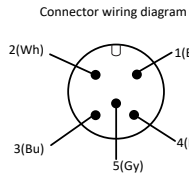

	Function	Pigtail cable product core color
1	Positive power supply	Brown
2	Analog output	Gray
3	Power negative	Blue
4	NPN/PNP	Black
5	External input/set to 0	Pink

Wiring diagram (NPN)

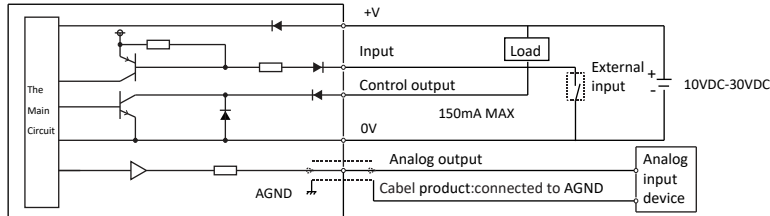

Wiring diagram (PNP)

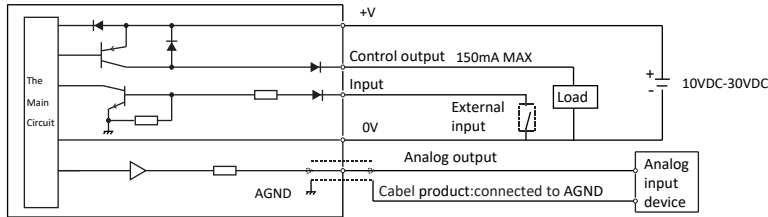

SAFETY PRECAUTIONS

⚠ DANGEROUS	<p>This product is for the purpose of object detection only. Do not use this product for the purpose of protecting human body or human body parts. This product should not be used as an explosion-proof product. Do not use this product in dangerous places or in the environment of potentially explosive gases.</p> <p>Faillure to use the control or adjustment device or perform the steps in accordance with this regulation may result in harmful radiation exposure.</p> <p>Ce produit est à des fins de détection d'objets seulement. N'utilisez pas ce produit dans le but de protéger le corps humain ou des parties du corps humain. Ce produit ne doit pas être utilisé comme produit antidéflagrant. Ne pas utiliser ce produit dans des endroits dangereux ou dans l'environnement de gaz potentiellement explosifs.</p> <p>La non-utilisation du dispositif de commande ou de réglage ou l'exécution des étapes conformément au présent règlement peut entraîner une exposition aux rayonnements nocifs.</p>
⚠ WARN	<p>This product is a sensor with DC power supply. Please do not apply AC power supply. If AC voltage applied, the product may explode or catch fire.</p> <p>Ce produit est un capteur avec alimentation cc. Veuillez ne pas appliquer d'alimentation en courant alternatif. En cas de tension, le produit peut exploser ou prendre feu.</p>
NOTICE	<p>Do not use the same wiring with the power cord and high-voltage line, otherwise the main module may fail or be damaged due to noise. When using a commercially available switching regulator, be sure to ground the housing ground terminal and the ground terminal.</p> <p>Please do not use this product outdoors.</p> <p>N'utilisez pas le même câblage avec le cordon d'alimentation et la ligne à haute tension, sinon le module principal peut tomber en panne ou être endommagé en raison du bruit. Lorsque vous utilisez un régulateur de commutation disponible dans le commerce, assurez-vous de mettre à la terre le terminal d'habitation et le terminal de terre. Veuillez ne pas utiliser ce produit à l'extérieur.</p>

TEACHING MODE DESCRIPTION

Teach

Detection mode setting description:
It is necessary to set the "Detection Mode Setting" in the menu to the corresponding function mode in advance.

1. Normal detection mode

In the menu, select the "□" mode, automatically enter the detection interface; Select the target object(*) within the effective detection distance and press the TEACH key, and prompt "GOOD" to complete the setting. The location of the target object is the judgement distance.

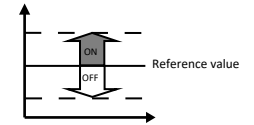

2. 1-point teaching window comparison mode

In the menu, select the "_N_1" mode, first enter the window size setting interface; The default setting value is 0.5mm, press UP/DOWN to adjust the window size setting value. Press the TEACH key to enter the measurement interface; within the effective measurement distance, select the target object(*), press TEACH key, prompt "GOOD", complete the setting. The position of the target object is the center, plus and minus setting value as window edge, and perform window mode judgement.

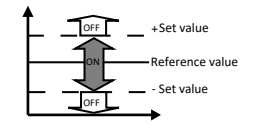

3. 2-point teaching window comparison mode

In the menu, select the "_N_2" mode, automatically enter the measurement interface. Select the target object 1(*) within the effective detection distance and press the TEACH key, and prompt "LP1" to complete p-1 setting. Select the target object 2(*) within the effective detection distance and press TEACH key, prompt "GOOD" to complete the p-2 setting. Use the distance between the location of target object 1 and target object 2 as the window to determine the window mode.

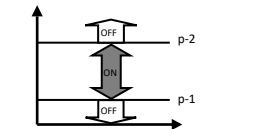

4. 3-point teaching window comparison mode

In the menu, select the "_N_3" mode, automatically enter the measurement interface. Select the target object 1(*) within the effective detection distance and press the TEACH key, and prompt "LP1" to complete p-1 setting. Select the target object 2(*) within the effective detection distance and press TEACH key, prompt "LP2" to complete the p-2 setting. Select the target object 3(*) within the effective detection distance and press TEACH key, prompt "GOOD" to complete the p-3 setting. Take the middle distance between p-1 and p-2 as window edge 1, and the middle distance between p-2 and p-3 as window edge 2, and perform window mode judgement.

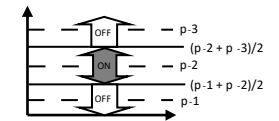

5. midpoint teaching mode

In the menu, select the "Nid" mode, automatically enter the measurement interface. Select the target object 1(*) within the effective detection distance and press the TEACH key, and prompt "LP1" to complete p-1 setting. Select the target object 2(*) within the effective detection distance and press TEACH key, prompt "GOOD" to complete the p-2 setting. Take the middle distance between p-1 and p-2 as the judgement distance.

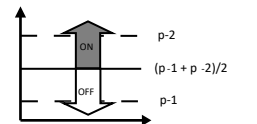

*Represents fine adjustment: After selecting the target object, you can fine-tune the distance of the target object with the UP/DOWN key, and then press the TEACH key to confirm.

接口定义和接线图

功能	出线式线芯颜色
1 电源正	棕
2 模拟量输出	灰
3 电源负	蓝
4 NPN/PNP	黑
5 激光使能输入/置零	粉
6 AGND	屏蔽线

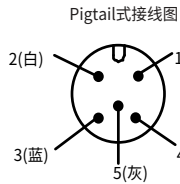

功能	Pigtail式线芯颜色
1 电源正	棕
2 模拟量输出	白
3 电源负	蓝
4 NPN/PNP	黑
5 激光使能输入/置零	灰

接线图 (NPN)

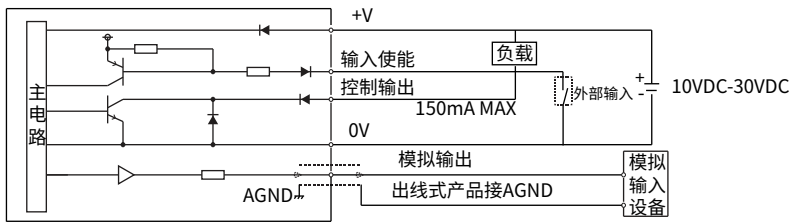

接线图 (PNP)

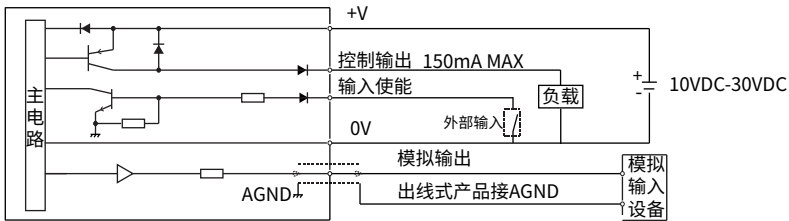

安全注意事项

⚠ 危险	本产品仅用于物体检测。请勿将本产品用于保护人体或人体部位。本产品不得用作防爆产品。请勿在危险场所或可能存在爆炸性气体的环境中使用本产品。本装置控制或调节装置的未使用或未按本规定执行步骤, 可能导致有害辐射暴露。未按照本规定使用控制或调节装置或未执行相应步骤, 可能导致有害辐射暴露。
⚠ 警告	该产品为直流电源传感器。请勿使用交流电源。如接入交流电压, 产品可能会爆炸或起火。
ℹ 通知	请不要将电源线与高压线路使用同一布线, 否则主模块可能会因噪声而故障或损坏。在使用市售的开关稳压器时, 请确保将外壳接地端子和地线端子接地。请勿在户外使用本产品。

教导模式说明

教导 检测模式设定说明: 需事先在Menu中将“检测模式设定”设为对应功能模式。	
1. 通常检测模式 在菜单中, 选定“ $\lfloor _ \rfloor$ ”模式, 自动进入测量界面; 在有效测量距离内, 选定目标物体(*), 按TEACH键, 提示“GOOD”, 完成设置; 目标物体所在位置即为判定距离。	
2. 1点教导模式 在菜单中, 选定“_N_1”模式, 先进入窗口大小设置界面; 设置值默认为0.5mm, 按UP/DOWN调整窗口大小设置值, 按TEACH键确认后进入测量界面; 在有效测量距离内, 选定目标物体(*), 按TEACH键, 提示“GOOD”, 完成设置; 目标物体所在位置为中心, 上下加减设置值为窗口, 进行窗口模式判定;	
3. 2点教导模式 在菜单中, 选定“_N_2”模式, 自动进入测量界面; 在有效测量距离内, 选定目标物体1(*), 按TEACH键, 提示“LP1”, 完成p-1设定; 在有效测量距离内, 选定目标物体2(*), 按TEACH键, 提示“GOOD”, 完成p-2设定; 以目标物体1和目标物体2所在位置之间的距离为窗口, 进行窗口模式判定;	
4. 3点教导模式 在菜单中, 选定“_N_3”模式, 自动进入测量界面; 在有效测量距离内, 选定目标物体1(*), 按TEACH键, 提示“LP1”, 完成p-1设定; 在有效测量距离内, 选定目标物体2(*), 按TEACH键, 提示“LP2”, 完成p-2设定; 在有效测量距离内, 选定目标物体3(*), 按TEACH键, 提示“GOOD”, 完成p-3设定; 以p-1和p-2的中间距离为窗口边缘1, 以p-2和p-3的中间距离为窗口边缘2, 进行窗口模式判定;	
5. 中点教导模式 在菜单中, 选定“Nid”模式, 自动进入测量界面; 在有效测量距离内, 选定目标物体1(*), 按TEACH键, 提示“LP1”, 完成p-1设定; 在有效测量距离内, 选定目标物体2(*), 按TEACH键, 提示“GOOD”, 完成p-2设定; 以p-1和p-2的中间距离为判定距离;	

*代表微调: 在选定目标物体后, 可通过UP/DOWN键微调目标物体距离, 之后再按TEACH键确定。

INSTRUCTION

1.Menu operation process

STEP

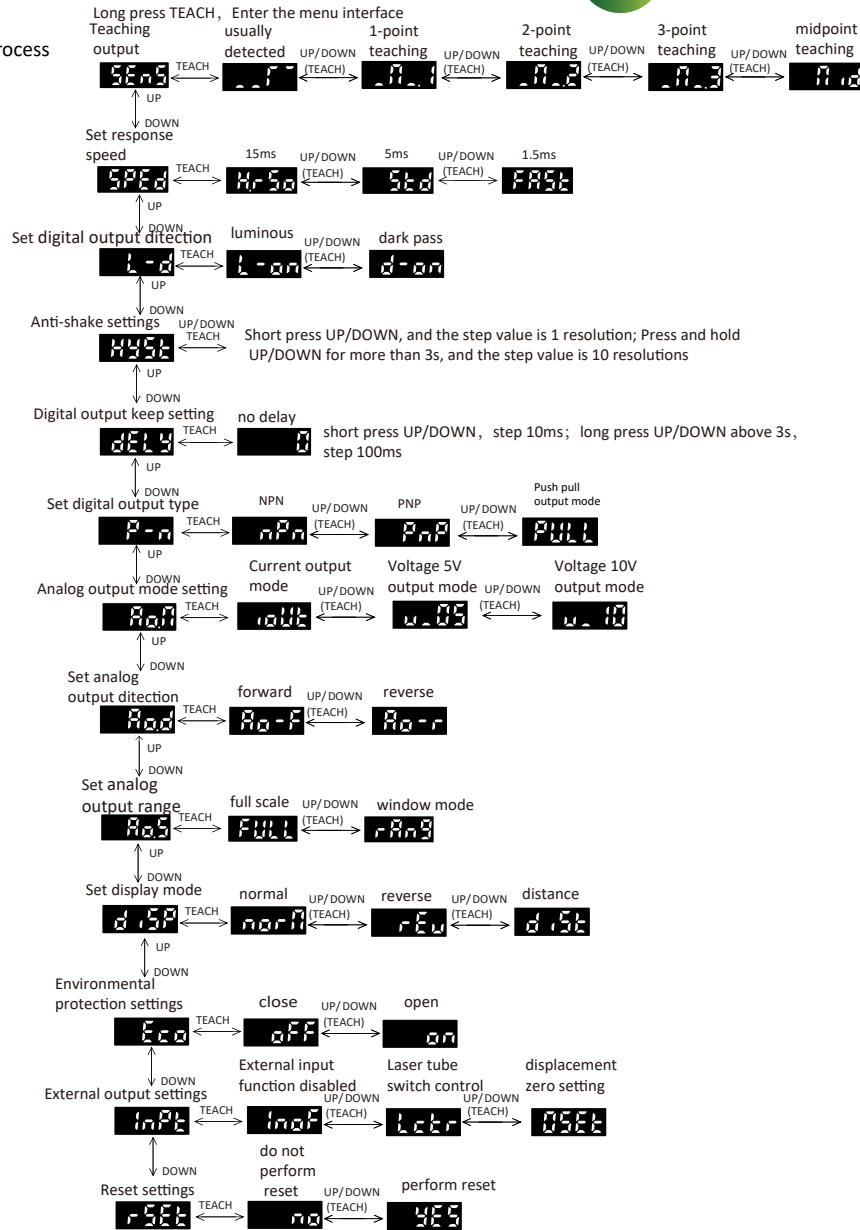

2.Description of button reset function

- 1) Simultaneously press and hold the UP and DOWN keys to reset the button to zero;
- 2) When no reset operation has been performed (key reset operation or external input trigger) and the current display mode is not distance mode, long press and hold the UP and DOWN keys,Then set the current detection position to the displacement zero point, and the red indicator light in the LED display screen remains constant;
- 3) When a reset operation has been performed (key reset operation or external input trigger), long press and hold the UP and DOWN keys again to restore the displacement zero point, and the LED displays the red indicator light in the screen is off;
- 4) When the current display mode is distance mode or the measured value exceeds the actual range of the sensor, long press and hold the UP and DOWN keys, and the LED display screen will display "ErrO";
- 5) When the lock button is turned on, long press and hold the UP and DOWN keys, and the LED display screen will display "Loc";

- 1.Ranging diplay
Measurement interface: Show actual measurement distance, when the distance is out of detected distance,it diplays"-----".
Display description:Take the center distance as 0 point,the distance less than the center is positive,the distance greater than the center is negative,and the displayed value is the offset value.
- 2.Menu and key operation
2.1 Enter the menu: Long presTEACH above 3s when it is in the measurement interface, enter the menu interface;
Exit menu: Long presTEACH above 3s when it is in the menu interface, or no key operation for 20s, return to measurement interface.
2.2 Menu operation
Enter the menu interface,diplay the main menu,switch the menu options by pressing the up/down key.
On the main menu interface,enter the submenu options by short pressing TEACH key.Under the submenu,short press up/down to select the parameter.Short press the TEACH key to confirm and return to the previous main menu.
1)Teaching output
The main menu shows"SEnS", press TEACH to enter the submenu;
Submenu items: "___|" usually detected mode (default) ; "_N_.1"1-point teaching window comparison mode ; "_N_.2"2-point teaching window comparison mode; "_N_.3"3-point teaching window comparison mode. "nid"midpoint teaching mode.
The above teaching modes are detailed in 6.Teaching mode description.
2)Set response speed:
The main menu shows"SPEd", press TEACH to enter the submenu;
Submenu items: "H.rSo"high precision 15ms;"Std"standard 5ms (default) ; "FAST"high speed 1.5ms;
3)Set digital output dtection
The main menu shows" L-d", press TEACH to enter the submenu;
Submenu items: "L-on"luminous (default) ; "d-on"dark pass;
4)Anti-shake settings
The menu displays "HySt". Press TEACH to enter the submenu.
The initial display resolution of the submenu * 10 is the hysteresis distance. When pressing UP/DOWN briefly, the step distance is 1 resolution;Press and hold the UP/DOWN key for more than 3s, and the step distance is 10 resolutions.
5)Digital output keep setting
The main menu shows"dELy", press TEACH to enter the submenu;
Submenu initial diplay" 0",no delay, short press UP/DOWN, step 10ms; long press UP/DOWN above 3s, step 100ms.
Setting range is 0~1000ms, initial value is 0ms.
6)Set digital output type
The main menu shows" P-n", press TEACH to enter the submenu;
Submenu items: " nPn"NPN output mode (default) ; "PnP"PNP output mode ; "PULL" push pull output mode.
7)Analog output mode setting
The main menu shows" Ao.N", press TEACH to enter the submenu;
Submenu items: "ioUt"current output mode (default) ; "v_5v"voltage 5v output mode;"v_10v"voltage 10v output mode.
8)Set analog output dtection
The main menu shows"Ao.d", press TEACH to enter the submenu;
Submenu items: "Ao-F"forward ; "Ao-r"reverse (default) .
Forward direction:short distance corresponds to small current/voltage,long distance corresponds to large current/voltage.The reverse is the opposite.
9)Set analog output range
The main menu shows"Ao.S", press TEACH to enter the submenu;
Submenu items: "FULL"full scale mode (default) ; "rAng"window mode.
When set to window mode,the analog output range can be set through the two-point teaching mode.
10)Set display mode
The main menu shows"diSP", press TEACH to enter the submenu;
Submenu items: "norN"normal displacement mode (default) ; "rEv"reverse displacement mode; "dist"distance mode.
11)Environmental protection settings
The main menu shows" Eco", press TEACH to enter the submenu;
Environmental protection function note: After the function is turned on,the LED will automatically turn off the display in 30s without any button.
12)External output settings
The main menu shows"INPt", press TEACH to enter the submenu;
Submenu items: "InoF"External input function disabled (default) ; "Lctr"laser tube switch control, turn on emission when there is no external input,and stop emission when the external input is low ; "OSet"displacement zero setting, external input connected to low level to trigger once, the current detection position is set as the displacement zero point,in this mode, the red indicator light on the display windoe is always on.The restoration of the displacement zero point is triggered again,and the red indicator light is off.
13)Reset settingssthe
The main menu shows"rSEt", press TEACH to enter the submenu;
Submenu items: " no"do not perform reset; " yES" perform reset, restore default settings.

- 2.3 Key lock function
Turn on key lock:In the measurement interface,press the TEACH and UP keys at the same time for more than 3s, the interface displays "Lc.on", and the menu function is invalid at this time.
Turn off the key lock:After the key lock is turned on,press the TEACH and UP keys at the same time for more than 3s, the interface displays "Lc.FA", press the TEACH and UP keys at the same time for more than 3s again, the interface displays "Lc.oF" and the key function are restored.

操作指南

1. 菜单操作流程



2. 按键归零功能说明

- 1) 同时长按UP和DOWN键进行按键归零;
- 2) 当未进行过归零操作(按键归零操作或外部输入触发),且当前显示模式不为距离模式,长按UP和DOWN键,则将当前检测位置设置为位移零点,此时LED显示屏中红色指示灯常亮;
- 3) 当已进行过归零操作(按键归零操作或外部输入触发),再次长按UP和DOWN键,则还原位移零点,LED显示屏中红色指示灯熄灭;
- 4) 当前显示模式为距离模式或测量值超出传感器实际量程时,长按UP和DOWN键,LED显示屏中将显示“Err0”;
- 5) 当开启按键锁定时,长按UP和DOWN键,LED显示屏中将显示“Loc”;

1. 测距显示

测量界面: 显示实际测量距离, 超出检测范围时显示“---”。
显示说明: 以中心距离为0点, 小于中心距离为正, 大于中心距离为负, 显示值为偏移值。

2. 菜单及按键操作

2.1 进入菜单: 测量界面下长按TEACH键3秒以上, 进入菜单界面;
退出菜单: 菜单界面下长按TEACH键3秒以上, 或20秒无按键操作, 返回测量界面。

2.2 菜单操作

进入菜单界面, 显示主菜单; 通过短按UP/DOWN键切换菜单选项;
主菜单界面, 通过短按TEACH键进入相应的子菜单选项, 子菜单下, 短按UP/DOWN进行参数选择, 在对应选项下短按TEACH键确认并返回上级主菜单;

1) 教导输出

主菜单显示“SEnS”, 按TEACH进入子菜单。

子菜单项: “_” 通常检测模式(默认); “_N_1” 1点教导窗口比较模式;
“_N_2” 2点教导窗口比较模式; “_N_3” 3点教导窗口比较模式; “Nid” 中点教导模式”。以上教导模式详见6.教导模式说明;

2) 设定响应速度:

主菜单显示“SPed”, 按TEACH进入子菜单;

子菜单项: “H.rSo” 高精度15ms; “Std” 标准5ms(默认); “FASt” 高速1.5ms;

3) 数字输出方向设定

主菜单显示“L-d”, 按TEACH进入子菜单;

子菜单项: “L-on” 亮通(默认); “d-on” 暗通;

4) 防抖设定(同回差)

菜单显示“HySt”, 按TEACH进入子菜单。

子菜单初始显示分辨率*10为迟滞距离, 短按UP/DOWN时, 步进距离为1个分辨率;
长按UP/DOWN键3s以上, 步进距离为10个分辨率。

5) 数字输出保持设定

菜单显示“delay”, 按TEACH进入子菜单。

子菜单显示“0” 无延迟, 短按UP/DOWN时, 步进距离10ms;

长按UP/DOWN键3s以上, 步进距离100ms。设置范围0~1000ms, 初始值为0ms。

6) 数字输出类型设定

主菜单显示“P-n”, 按TEACH进入子菜单。

子菜单项: “nPn” NPN输出模式(默认); “PnP” PNP输出模式; “PULL” 推挽输出模式。

7) 模拟输出模式设定

主菜单显示“Ao.N”, 按TEACH进入子菜单。

子菜单项: “ioUt” 电流输出模式(默认); “v_05” 电压5V输出模式; “v_10” 电压10V输出模式。

8) 设定模拟输出方向

菜单显示“Ao.d”, 按TEACH进入子菜单。

子菜单项: “Ao-F” 正向; “Ao-r” 反向(默认)。

正向: 近距离对应小电流/电压, 远距离对应大电流/电压。反向相反。

9) 设定模拟输出范围

菜单显示“Ao.S”, 按TEACH进入子菜单。

子菜单项: “FULL” 全量程模式(默认); “rAng” 窗口模式;

设置为窗口模式时, 可通过两点教导模式设定模拟输出范围。

10) 设定显示模式

菜单显示“diSP”, 按TEACH进入子菜单。

子菜单项: “norN” 正常位移模式(默认); “rEv” 反转位移模式; “dist” 距离模式。

11) 环保设定

菜单显示“Eco”, 按TEACH进入子菜单。

环保功能说明: 该功能打开后, 30s无按键自动熄灭Led显示。

12) 外部输入设定

菜单显示“InPt”, 按TEACH进入子菜单。

子菜单项: “InoF” 外部输入功能禁止(默认); “Lctr” 激光管开光控制, 无外部输入时开启投光, 外部输入为低时停止投光; “OSet” 位移零点设置, 外部输入接低电平触发一次, 则将当前检测位置设置为位移零点, 此模式显示窗红色指示灯常亮, 再次触发还原位移零点, 指示灯灭。

13) 复位设定

菜单显示“rSet”, 按TEACH进入子菜单。

子菜单项: “no” 不执行复位; “yEs” 执行复位, 恢复默认设置。

2.3 按键锁定功能

开启按键锁定: 测量界面下, 同时按下TEACH和UP键3秒以上, 界面显示“Lc.on”, 此时菜单功能失效;

关闭按键锁定: 按键锁定开启后, 同时按下TEACH和UP键3秒以上, 界面显示“Lc.FA”, 再次同时按下TEACH和UP键3秒以上, 界面显示“Lc.oF”, 按键功能恢复。

DIGITAL TUBE DIAPLAY INTERPRETATION

SenS	sens	teaching output
---	_m	usually detected
M_1	_m_1	1-point teaching
M_2	_m_2	2-point teaching
M_3	_m_3	3-point teaching
M_d	_mid	midpoint teaching
SPEd	sped	set response speed
Hr50	h.rso	high precision 15ms
Std	std	standard 5ms
FRSt	fast	high speed 1.5ms
L-d	l-d	set switch output dtection
L-on	l-on	luminous
d-on	d-on	dark pass
Hyst	hyst	anti-shake settings
dELy	dely	switch output keep settings
0	0	no delay
P-n	p-n	set switch output
nPN	nPN	NPN
pNP	pNP	PNP
PULL	pull	push-pull output mode
RoM	rom	set analog output mode
iout	iout	current output mode
v_5V	v-5V	voltage 5V output mode
v_10V	v-10V	voltage 10V output mode
RoD	rod	set analog output direction
ao-f	ao-f	reverse
ao-r	ao-r	forward
RoS	aos	set analog output range
FULL	full	full scale
rRng	rang	window mode(corresponding to two-point teaching mode)
dISP	disp	set diaplay mode
norm	norm	normal displacement mode
rev	rev	reverse displacement mode
dist	dist	distance mode
eco	eco	environmental protection settings
off	off	environmental protection close
on	on	environmental protection open
inpt	inpt	external output settings
inof	inof	external input function disabled
lctr	lctr	laser tube switch control
0set	0set	displacement zero setting
rest	rest	reset settings
no	no	do not perform reset
YES	yes	perform reset

INSTALLATON DIAGRAM

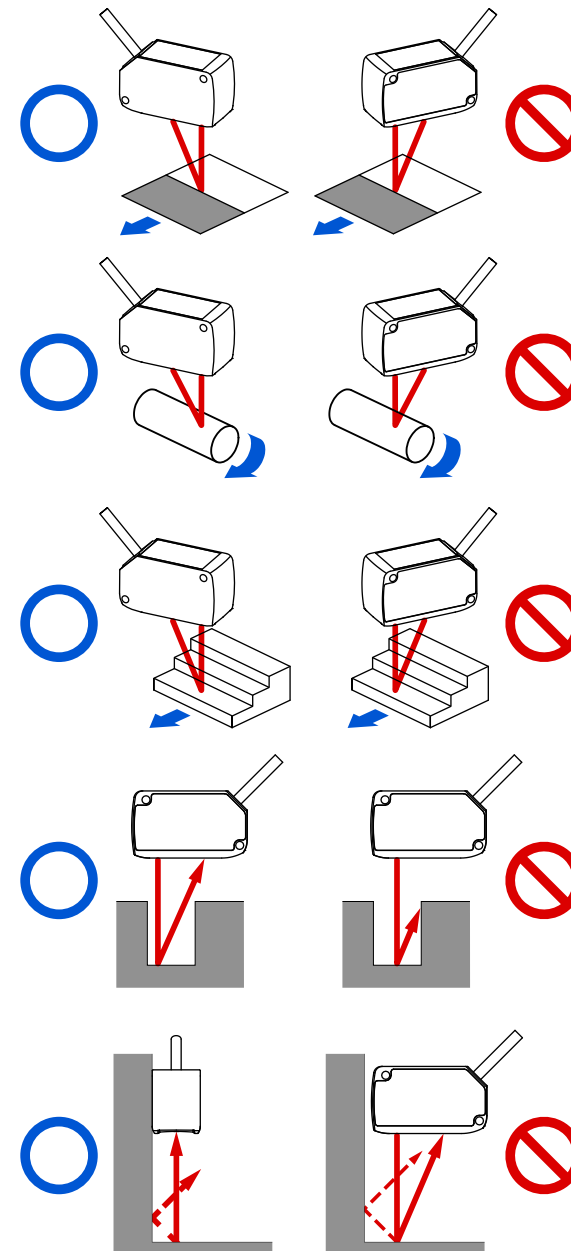

1. In the case of color or material difference
When the material or color of moving object is extremely different, install it in the direction shown on the left to keep the measurement error to a minimum.

2. Detect rotating objects
When detecting a rotating object, install it in the direction shown on the left, which can suppress the influence of the object's vertical vibration and position shift.

3. When there is a step
If there is a step in the moving detection object, install it according to the method shown on the left, so as to suppress the influence of the step edge during measurement.

4. Measure in narrow places and recessed parts
In the case of measuring in a narrow place or hole, please be careful not to block the light path from the light emitting part to the light receiving part when installing.

5. When installed on the wall
Please install according to the method shown on the left to avoid the multiple reflected light from the wall entering the light receiving part.

数码管显示释义

SENS	sens	教导输出
_m	_m	通常检测
_m_1	_m_1	1点教导
_m_2	_m_2	2点教导
_m_3	_m_3	3点教导
_mid	_mid	中点教导
SPED	sped	设定响应速度
H.50	h.rso	高精度速度15ms
50	std	标准速度5ms
FAST	fast	高速1.5ms
l-d	l-d	设定开关量输出方向
l-on	l-on	亮通
d-on	d-on	暗通
HYST	hyst	防抖设定
dely	dely	开关量输出保持设定
0	0	无延迟
P-n	p-n	设定开关量输出类型
nPN	nPN	NPN输出模式
pnp	pnp	PNP输出模式
PULL	pull	推挽输出模式
ROM	rom	设定模拟输出模式
iout	iout	电流输出模式
v-5V	v-5V	电压5V输出模式
v-10V	v-10V	电压10V输出模式
rod	rod	设定模拟输出方向
ao-f	ao-f	正向
ao-r	ao-r	反向
aos	aos	设定模拟输出范围
full	full	全量程模式
rang	rang	窗口模式 (对应两点教导模式)
disp	disp	设定显示模式
norm	norm	正常位移模式
rev	rev	反转位移模式
dist	dist	距离模式
eco	eco	环保设定
off	off	环保关
on	on	环保开
inpt	inpt	外部输入设定
inof	inof	外部输入功能静止
lctr	lctr	激光管开关控制
0set	0set	位移零点设置
rest	rest	复位设定
no	no	不执行复位
YES	yes	执行复位

安装示意图

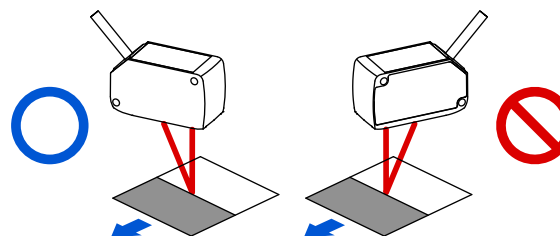

1. 材质、有色差的情况下测量时，移动的检测对象物的材质、颜色极端不同的情况下，按照左图所示方向进行安装，从而可将测量误差控制在最小限度。

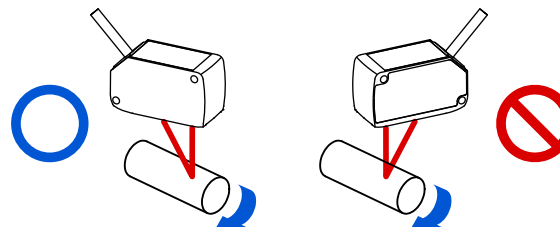

2. 对旋转的对象物进行检测时，按照左图所示方向进行安装，从而可抑制对象物的上下振动和位置偏移等的影响。

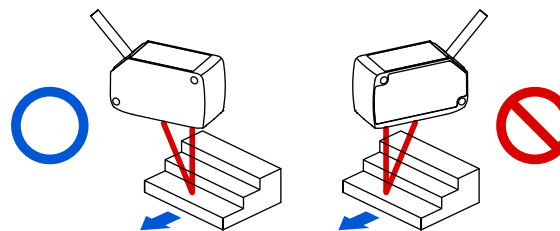

3. 存在段差的情况下移动的检测对象物存在段差的情况下，请按照左图所示方法进行安装，从而可在测量时抑制段差边缘所产生的影响。

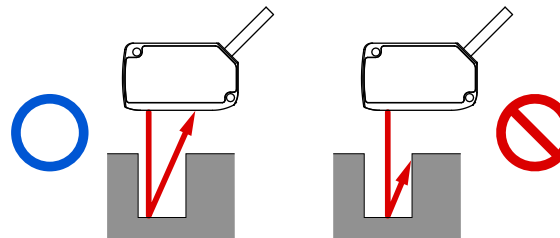

4. 在狭窄场所和凹陷部分进行测量在狭窄场所和孔中进行测量的情况下，安装时，请注意避免遮挡投光部至受光部的光路。

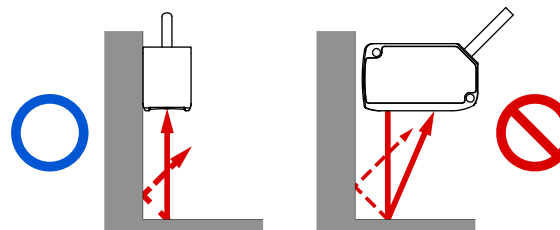

5. 安装在墙上时请按照左图所示方法进行安装，以免墙面产生的多重反射光入光到受光部分。另外墙面反射率较高的情况下，如改成无光泽的黑色，则效果更好。