

### Product Description

- Laser displacement sensor ,680nm laser source,FULL Metal JACKET,durable,better protective performance,small light spot,high precision,LED display and key setting.Suitable for dispensing machine,packing,automobile AGV and other industries.



### Product features:

- Support two-way switch output,NPN/PNP can be set.
- Four white digital tubes,clear and bright
- Strong ambient light resistance and compact size
- Support multiple detection modes,multi-scene applications.

Type	Measurement range	Beam diameter	Repeatability	Absolute accuracy	Resolution
OSM41-KL10C2B6*M	100...9999mm	0.4 divergence angle (10mm@2M 20mm@4M 50mm@10M)	tabula rasa	tabula rasa	1mm
OSM41-KL10C2B6*-Q12			10mm(dis<5m,90%reflection) 30mm(dis<10m,90%reflection) blackboard	10mm(dis<5m,90%reflection) 30mm(dis<10m,90%reflection) blackboard	
			30mm(dis<5m,6%reflection) 50mm(dis<10m,6%reflection)	30mm(dis<5m,6%reflection) 50mm(dis<10m,6%reflection)	

Note 1: This product is a laser product, which can be used after 10 minutes of preheating after power-on.

Note 2: For breakout products, \*M represents the cable length; if not specified, the default is 2 meters.

For pigtail products, \* represents the cable length in meters. If there is no Wei connector product

### TECHNICAL SPECIFICATION

<b>OPERATING VOLTAGE</b>	10...30VDC	<b>WORKING TEMPERATURE</b>	-10°C... +50°C
<b>POWER SUPPLY</b>	<1W	<b>ANTI-AMBIENT LIGHT ABILITY</b>	>8000lux
<b>LIGHT SOURCE TYPE</b>	680nm red laser, class1 grade	<b>PROTECTION DEGREE</b>	IP67
<b>TWO-WAY CONTROL OUTPUT</b>	NPN/PNP can be set	<b>HOUSING MATERIAL</b>	Die-cast zinc
<b>SETTING MODE</b>	BUTTON	<b>WINDOWS MATERIAL</b>	Glass
<b>RESPONSE TIME</b>	10Hz/25Hz 50Hz/100Hz	<b>CONNECTIONS</b>	Cable/Pigtail Cable

### DIMENSIONS

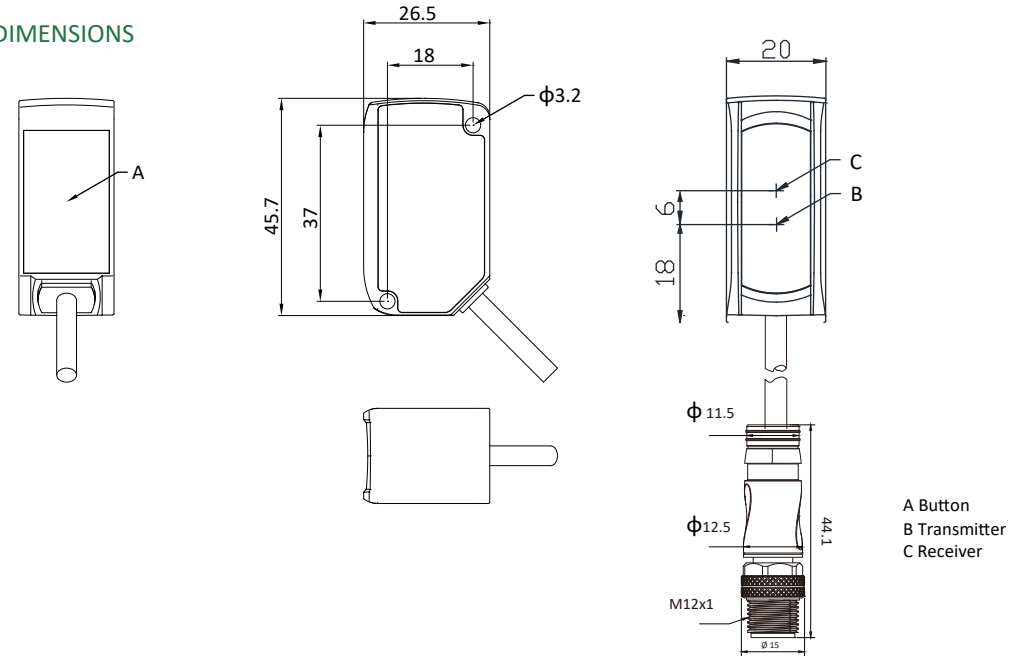

### INTERFACE DEFINITION AND WIRING DIAGRAM

	Function	Cabel product core color
1	Positive power supply	Brown
2	NPN/PNP2	Gray
3	Power negative	Blue
4	NPN/PNP1	Black

	Function	Pigtail cable product core color
1	Positive power supply	Brown
2	NPN/PNP2	Gray
3	Power negative	Blue
4	NPN/PNP1	Black

Connector wiring diagram

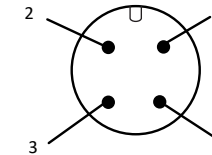

## 产品说明:

- 激光位移传感器, 680nm激光光源, 全金属外壳, 坚固耐用, 防护性能更好, 体积小, 光斑小, 精度高, LED显示和按键设置。适用点胶机、包装、汽车、AGV等行业应用。

## 产品特点:

- 支持两路开关量输出, NPN/PNP可设定
- 四位白色数码管, 明亮清晰
- 抗环境光能力强, 紧凑尺寸
- 支持多种检测模式, 多场景应用

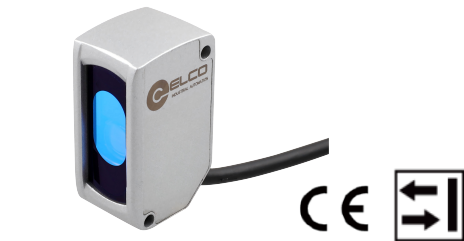

型号	检测距离	光束直径	重复精度	绝对精度	分辨率
OSM41-KL10C2B6*M	100...9999mm	0.4°发散角 (10mm@2M 20mm@4M 50mm@10M)	白板 10mm(dis<5m,90%反射) 30mm(dis<10m,90%反射)	白板 10mm(dis<5m,90%反射) 30mm(dis<10m,90%反射)	1mm
OSM41-KL10C2B6*-Q12			黑板 30mm(dis<5m,6%反射) 50mm(dis<10m,6%反射)	黑板 30mm(dis<5m,6%反射) 50mm(dis<10m,6%反射)	

注1: 本产品为激光类产品, 上电预热十分钟后使用。

注2: 出线产品\*M代表线长, 如无为默认2M长度。pigtail产品\*代表线长, 单位为米, 若无为接插件产品。

## 技术参数

工作电压	10...30VDC	工作温度	-10°C... +50°C
功率	<1W	抗环境光能力	>8000lux
光源	680nm红激光, class1等级	防护等级	IP67
两路控制输出	NPN/PNP可选	外壳	压铸铝
设置方式	按键	窗口	玻璃
检测频率	10Hz/25Hz/ 50Hz/100Hz	连接形式	线缆式/pigtail线缆

## 外型尺寸

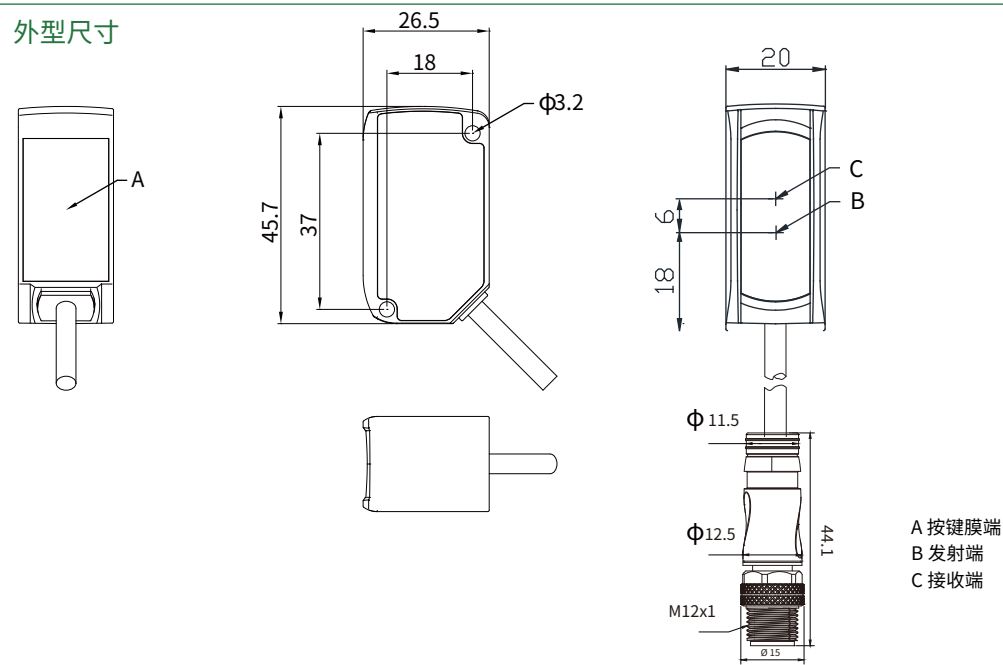

## 接口定义和接线图

	功能	出线式 线芯颜色
1	电源正	棕
2	NPN/PNP2	粉
3	电源负	蓝
4	NPN/PNP1	黑

	功能	Pigtail式 线芯颜色
1	电源正	棕
2	NPN/PNP2	白
3	电源负	蓝
4	NPN/PNP1	黑

Pigtail式接线图

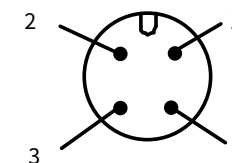

Wiring diagram (NPN)

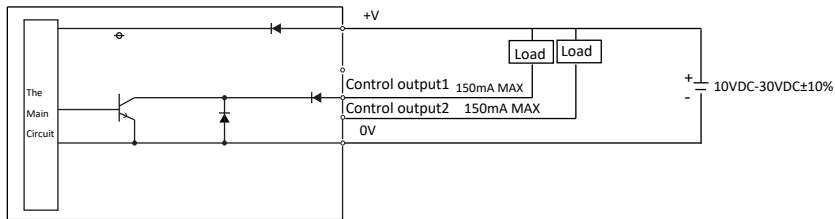

Wiring diagram (PNP)

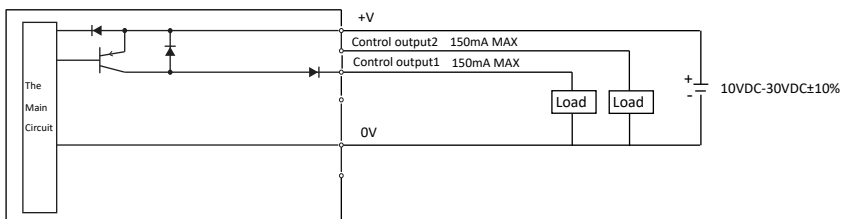

TEACHING MODE DESCRIPTION

Teach	
<p>Detection mode setting description: It is necessary to set the "Detection Mode Setting" in the menu to the corresponding function mode in advance.</p>	
<p>1. Normal detection mode In the menu, select the " _   " mode, automatically enter the detection interface; Select the target object(*) within the effective detection distance and press the TEACH key, and prompt "GOOD" to complete the setting. The location of the target object is the judgement distance.</p>	
<p>2. 2-point teaching window comparison mode In the menu, select the " _N_2_" mode, automatically enter the measurement interface. Select the target object 1(*) within the effective detection distance and press the TEACH key, and prompt "LP1" to complete p-1 setting. Select the target object 2(*) within the effective detection distance and press TEACH key, prompt "GOOD" to complete the p-2 setting. Use the distance between the location of target object 1 and target object 2 as the window to determine the window mode.</p>	
<p>3. midpoint teaching mode In the menu, select the "Nid" mode, automatically enter the measurement interface. Select the target object 1(*) within the effective detection distance and press the TEACH key, and prompt "LP1" to complete p-1 setting. Select the target object 2(*) within the effective detection distance and press TEACH key, prompt "GOOD" to complete the p-2 setting. Take the middle distance between p-1 and p-2 as the judgement distance.</p>	

\*Represents fine adjustment: After selecting the target object, you can fine-tune the distance of the target object with the UP/DOWN key, and then press the TEACH key to confirm.

INSTRUCTION

1. Menu operation process

STEP

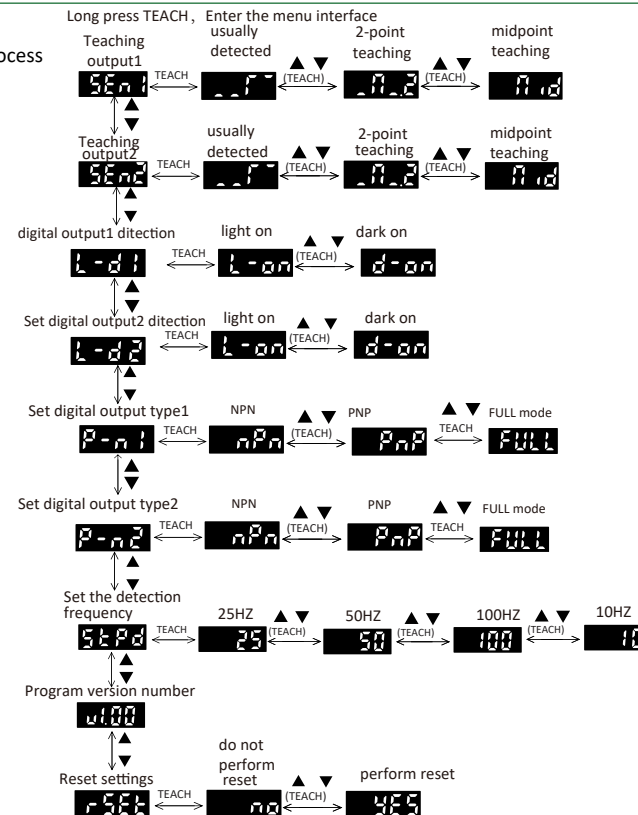

2. Ranging display  
Measurement interface: Show actual measurement distance, when the distance is out of detected distance, it displays "----".
3. Menu and key operation  
3.1 Enter the menu: Long press TEACH above 3s when it is in the measurement interface, enter the menu interface; Exit menu: Long press TEACH above 3s when it is in the menu interface, or no key operation for 20s, return to measurement interface.
- 3.2 Menu operation  
Enter the menu interface, display the main menu, switch the menu options by pressing the up/down key.  
On the main menu interface, enter the submenu options by short pressing TEACH key. Enter the submenu, short press up/down to select the parameter. Short press the TEACH key to confirm and return to the previous main menu.
  - 1) Teaching output1  
The main menu shows "SEn1", press TEACH to enter the submenu; Submenu items: " \_ | " usually detected mode (default); " \_N\_2\_" 2-point teaching window comparison mode; "nid" midpoint teaching mode. The above teaching modes are detailed in 6. Teaching mode description.
  - 2) Teaching output2  
The main menu shows "SEn2", press TEACH to enter the submenu; Submenu items: " \_ | " usually detected mode (default); " \_N\_2\_" 2-point teaching window comparison mode; "nid" midpoint teaching mode. The above teaching modes are detailed in Teaching mode description.
  - 3) Set digital output detection1  
The main menu shows "L-d1", press TEACH to enter the submenu; Submenu items: "L-on" luminous (default); "d-on" dark pass;
  - 4) Set digital output detection2  
The main menu shows "L-d2", press TEACH to enter the submenu; Submenu items: "L-on" luminous (default); "d-on" dark pass;
  - 5) Set digital output type1  
The main menu shows "P-n1", press TEACH to enter the submenu; Submenu items: "nPn" NPN output mode (default); "PnP" PNP output mode; "PULL" push pull output mode.
  - 6) Set digital output type2  
The main menu shows "P-n2", press TEACH to enter the submenu; Submenu items: "nPn" NPN output mode (default); "PnP" PNP output mode; "PULL" push pull output mode.
  - 7) Set the detection frequency  
The main menu shows "StPd", press TEACH to enter the submenu; Submenu items: "25" detection frequency is 25 Hz (default); "50" detection frequency is 50 Hz; "100" detection frequency is 100 Hz; "10" detection frequency is 10 Hz;
  - 8) Program version number  
The main menu shows "vXXX", the displayed value of this menu changes with the upgrade of program version number, and it is variable; (subject to reality)
  - 9) Reset settings  
The main menu shows "rSet", press TEACH to enter the submenu; Submenu items: "no" do not perform reset; "YES" perform reset, restore default settings.

接线图 (NPN)

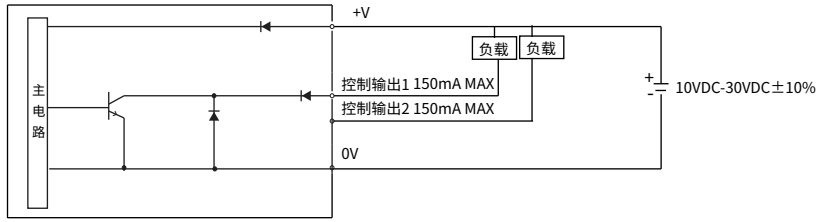

接线图 (PNP)

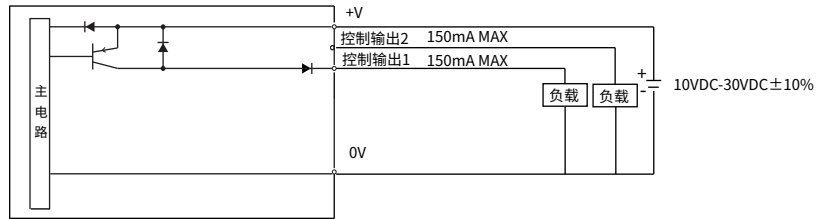

教导模式说明

<p><b>教导</b></p> <p>检测模式设定说明： 需事先在Menu中将“检测模式设定”设为对应功能模式。</p>	
<p><b>1. 通常检测模式</b></p> <p>在菜单中，选定“<input type="checkbox"/>”模式，自动进入测量界面；在有效测量距离内，选定目标物体(*)，按TEACH键，提示“GOOD”，完成设置；目标物体所在位置即为判定距离。</p>	
<p><b>2. 2点教导模式</b></p> <p>在菜单中，选定“_N_2”模式，自动进入测量界面；在有效测量距离内，选定目标物体1(*)，按TEACH键，提示“LP1”，完成p-1设定；在有效测量距离内，选定目标物体2(*)，按TEACH键，提示“GOOD”，完成p-2设定；以目标物体1和目标物体2所在位置之间的距离为窗口，进行窗口模式判定；</p>	
<p><b>3. 中点教导模式</b></p> <p>在菜单中，选定“Nid”模式，自动进入测量界面；在有效测量距离内，选定目标物体1(*)，按TEACH键，提示“LP1”，完成p-1设定；在有效测量距离内，选定目标物体2(*)，按TEACH键，提示“GOOD”，完成p-2设定；以p-1和p-2的中间距离为判定距离；</p>	

\*代表微调：在选定目标物体后，可通过UP/DOWN键微调目标物体距离，之后再按TEACH键确定。

操作指南

1. 菜单操作流程

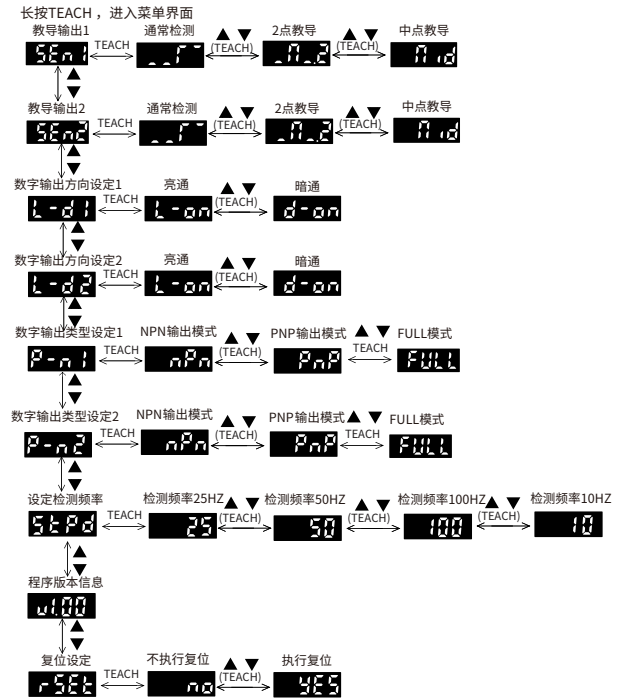

- 1. 测距显示**  
测量界面：显示实际测量距离，超出检测范围时显示“----”。
- 2. 菜单及按键操作**
  - 2.1 进入菜单：**测量界面下长按TEACH键3秒以上，进入菜单界面；退出菜单：菜单界面下长按TEACH键3秒以上，或20秒无按键操作，返回测量界面。
  - 2.2 菜单操作**  
进入菜单界面，显示主菜单；通过短按UP/DOWN键切换菜单选项；主菜单界面，通过短按TEACH键进入相应的子菜单选项，子菜单下，短按UP/DOWN进行参数选择，在对应选项下短按TEACH键确认并返回上级主菜单；
- 1) 教导输出1**  
主菜单显示“SEn1”，按TEACH进入子菜单。子菜单项：“”通常检测模式（默认）；“\_N\_1”1点教导窗口比较模式；“\_N\_2”2点教导窗口比较模式；“\_N\_3”3点教导窗口比较模式；“Nid中点教导模式”。以上教导模式详见6.教导模式说明；
- 2) 教导输出2**  
主菜单显示“SEn2”，按TEACH进入子菜单。子菜单项：“”通常检测模式（默认）；“\_N\_2”2点教导窗口比较模式；“Nid中点教导模式”。以上教导模式详见教导模式说明；
- 3) 数字输出方向设定1**  
主菜单显示“L-d1”，按TEACH进入子菜单；子菜单项：“L-on”亮通（默认）；“d-on”暗通；
- 4) 数字输出方向设定2**  
主菜单显示“L-d2”，按TEACH进入子菜单；子菜单项：“L-on”亮通（默认）；“d-on”暗通；
- 5) 数字输出类型设定1**  
主菜单显示“P-n1”，按TEACH进入子菜单。  
子菜单项：“nPn”NPN输出模式（默认）；“PnP”PNP输出模式；“PULL”推挽输出模式。
- 6) 数字输出类型设定2**  
主菜单显示“P-n2”，按TEACH进入子菜单。子菜单项：“nPn”NPN输出模式（默认）；“PnP”PNP输出模式；“PULL”推挽输出模式。
- 7) 设定检测频率**  
菜单显示“StPd”，按TEACH进入子菜单。  
子菜单项：“25”检测频率25Hz（默认）；“50”检测频率50Hz；“100”检测频率100Hz；“10”检测频率10Hz。
- 8) 版本信息**  
菜单显示“vXXX”；此项菜单显示值跟随程序版本号升级而变化，为变量；（以实际为准）
- 9) 复位设定**  
菜单显示“rSet”，按TEACH进入子菜单。子菜单项：“no”不执行复位；“yES”执行复位，恢复默认设置。