

Product Description

- Laser displacement sensor ,655nm laser source,FULL Metal JACKET,durable,better protective performance,small light spot,high precision,LED display and key setting,displacement ranging from 50 mm to 400 mm center point.
- Suitable for dispensing machine,packing,automobile AGV and other industries.



Product features:

- Short,medium and long distances are available.
- Support switch output,NPN/PNP can be set.
- Support laser light source control through external input.
- Support ECO mode setting.
- Four white digital tubes,clear and bright
- Strong ambient light resistance and compact size
- Support multiple detection modes,multi-scene applications.



TECHNICAL SPECIFICATION

OPERATING VOLTAGE	10...30 V DC , Class 2	WORKING TEMPERATURE	-10°C ... +50°C
POWER SUPPLY	<1W	AMBIENT ILLUMINANCE	Under 3000lux
LIGHT SOURCE TYPE	Laser class 2, 655nm	PROTECTION DEGREE	IP67
CONTROL OUTPUT*2	NPN/PNP can be set	HOUSING MATERIAL	Die-cast zinc
RESPONSE TIME	15ms/5ms/1.5ms	WINDOWS MATERIAL	Glass
CONNECTIONS	Cable/Pigtail Cable	LASER LABEL	pasting on packing bag
		MAINTAIN	disassemble; please return to ELCO
		MAXIMUM HUMIDITY	Max.85%Rh
		ALTITUDE	Up to 2000m
		POLLUTION DEGREE	3



DIMENSIONS

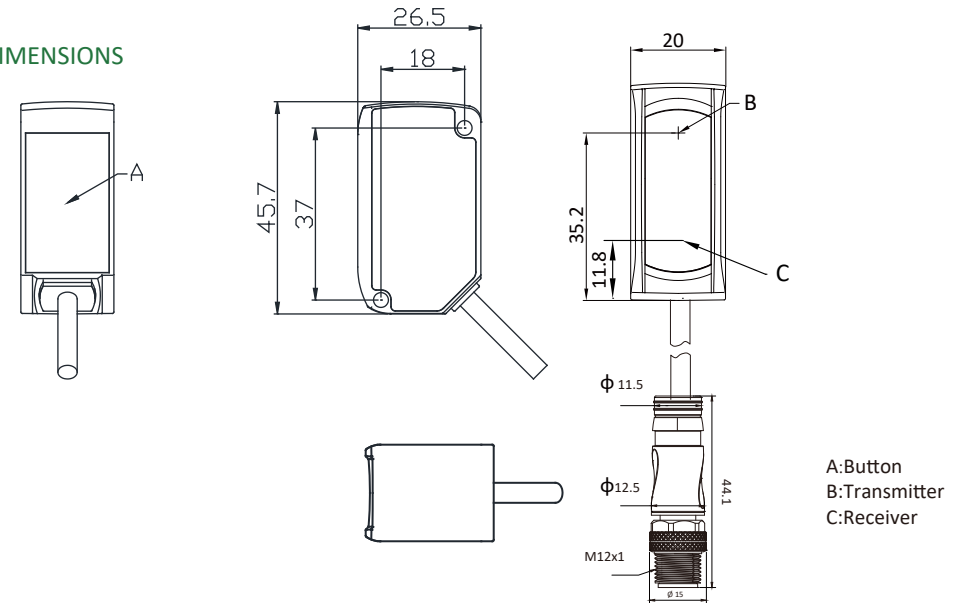

A:Button
B:Transmitter
C:Receiver

Type	Measurement range	Measurement center distance	Beam diameter	Repeatability	Linearity	Resolution
OSM41-KL30C2B6*M	25...35mm	30mm	0.2mm @50mm	10µm	±0.1%F.S.	0.001mm
OSM41-KL30C2B6-* -Q12.1						
OSM41-KL50C2B6*M	35...65mm	50mm	0.5mm @50mm	30µm	±0.1%F.S.	0.01mm
OSM41-KL50C2B6-* -Q12.1						
OSM41-KL100C2B6*M	65...135mm	100mm	0.5mm @100mm	70µm	±0.1%F.S.	0.01mm
OSM41-KL100C2B6-* -Q12.1						
OSM41-KL200C2B6*M	120...280mm	200mm	1mm @200mm	200µm	±0.2%F.S.	0.1mm
OSM41-KL200C2B6-* -Q12.1						
OSM41-KL400C2B6*M	200...600mm	400mm	1mm @150mm 2mm @600mm	0.5mm(≤400mm) 1mm(≤600mm)	±0.2%F.S.(≤400mm) ±0.3%F.S.(≤600mm)	0.1mm
OSM41-KL400C2B6-* -Q12.1						

Note 1: This product is a laser product, which can be used after 10 minutes of preheating after power-on.
 Note 2: For breakout products, *M represents the cable length; if not specified, the default is 2 meters.
 For pigtail products, * represents the cable length in meters. If there is no Wei connector product

INTERFACE DEFINITION AND WIRING DIAGRAM

Function	Cabel product core color
1 Positive power supply	Brown
2 NPN/PNP2	Gray
3 Power negative	Blue
4 NPN/PNP1	Black
5 External input/set to 0	Pink

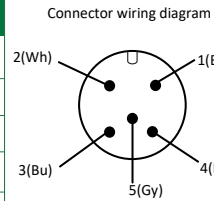

Function	Pigtail cable product core color
1 Positive power supply	Brown
2 NPN/PNP2	Gray
3 Power negative	Blue
4 NPN/PNP1	Black
5 External input/set to 0	Pink

Wiring diagram (NPN)

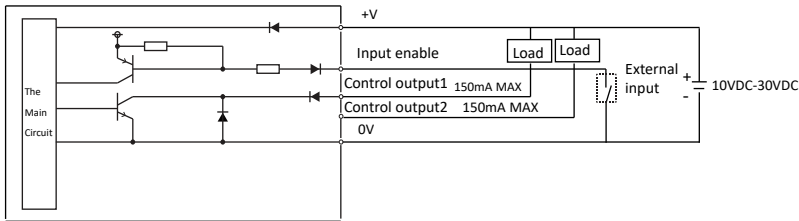

Wiring diagram (PNP)

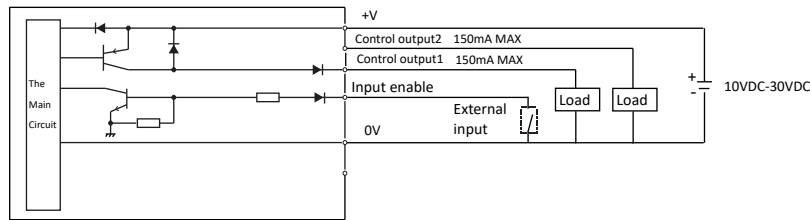

SAFETY PRECAUTIONS

⚠ DANGER	<p>This product is for the purpose of object detection only. Do not use this product for the purpose of protecting human body or human body parts. This product should not be used as an explosion-proof product. Do not use this product in dangerous places or in the environment of potentially explosive gases. Failure to use the control or adjustment device or perform the steps in accordance with this regulation may result in harmful radiation exposure.</p> <p>Ce produit est à des fins de détection d'objets seulement. N'utilisez pas ce produit dans le but de protéger le corps humain ou des parties du corps humain. Ce produit ne doit pas être utilisé comme produit antidéflagrant. Ne pas utiliser ce produit dans des endroits dangereux ou dans l'environnement de gaz potentiellement explosifs. La non-utilisation du dispositif de commande ou de réglage ou l'exécution des étapes conformément au présent règlement peut entraîner une exposition aux rayonnements nocifs.</p>
⚠ WARN	<p>This product is a sensor with DC power supply. Please do not apply AC power supply. If AC voltage applied, the product may explode or catch fire.</p> <p>Ce produit est un capteur avec alimentation cc. Veuillez ne pas appliquer d'alimentation en courant alternatif. En cas de tension, le produit peut exploser ou prendre feu.</p>
NOTICE	<p>Do not use the same wiring with the power cord and high-voltage line, otherwise the main module may fail or be damaged due to noise. When using a commercially available switching regulator, be sure to ground the housing/ground terminal and the ground terminal. Please do not use this product outdoors.</p> <p>N'utilisez pas le même câblage avec le cordon d'alimentation et la ligne à haute tension, sinon le module principal peut tomber en panne ou être endommagé en raison du bruit. Lorsque vous utilisez un régulateur de commutation disponible dans le commerce, assurez-vous de mettre à la terre le terminal d'habitation et le terminal de terre. Veuillez ne pas utiliser ce produit à l'extérieur.</p>

TEACHING MODE DESCRIPTION

Teach

Detection mode setting description: It is necessary to set the "Detection Mode Setting" in the menu to the corresponding function mode in advance.

1. Normal detection mode
In the menu, select the "□" mode, automatically enter the detection interface; Select the target object(*) within the effective detection distance and press the TEACH key, and prompt "GOOD" to complete the setting. The location of the target object is the judgement distance.

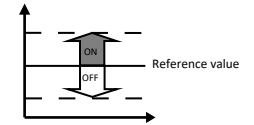

2. 1-point teaching window comparison mode
In the menu, select the "_N_1" mode, first enter the window size setting interface; The default setting value is 0.5mm, press UP/DOWN to adjust the window size setting value. Press the TEACH key to enter the measurement interface; within the effective measurement distance, select the target object(*), press TEACH key, prompt "GOOD", complete the setting. The position of the target object is the center, plus and minus setting value as window edge, and perform window mode judgement.

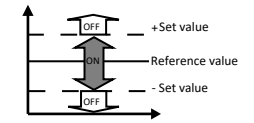

3. 2-point teaching window comparison mode
In the menu, select the "_N_2" mode, automatically enter the measurement interface. Select the target object 1(*) within the effective detection distance and press the TEACH key, and prompt "LP1" to complete p-1 setting. Select the target object 2(*) within the effective detection distance and press TEACH key, prompt "GOOD" to complete the p-2 setting. Use the distance between the location of target object 1 and target object 2 as the window to determine the window mode.

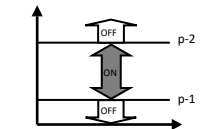

4. 3-point teaching window comparison mode
In the menu, select the "_N_3" mode, automatically enter the measurement interface. Select the target object 1(*) within the effective detection distance and press the TEACH key, and prompt "LP1" to complete p-1 setting. Select the target object 2(*) within the effective detection distance and press TEACH key, prompt "GOOD" to complete the p-2 setting. Select the target object 3(*) within the effective detection distance and press TEACH key, prompt "GOOD" to complete the p-3 setting. Take the middle distance between p-1 and p-2 as window edge 1, and the middle distance between p-2 and p-3 as window edge 2, and perform window mode judgement.

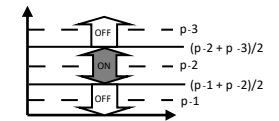

5. midpoint teaching mode
In the menu, select the "Nid" mode, automatically enter the measurement interface. Select the target object 1(*) within the effective detection distance and press the TEACH key, and prompt "LP1" to complete p-1 setting. Select the target object 2(*) within the effective detection distance and press TEACH key, prompt "GOOD" to complete the p-2 setting. Take the middle distance between p-1 and p-2 as the judgement distance.

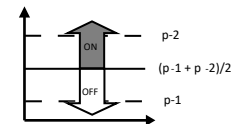

*Represents fine adjustment: After selecting the target object, you can fine-tune the distance of the target object with the UP/DOWN key, and then press the TEACH key to confirm.

接口定义和接线图

功能	出线式线芯颜色
1 电源正	棕
2 NPN/PNP2	灰
3 电源负	蓝
4 NPN/PNP1	黑
5 激光使能输入/置零	粉

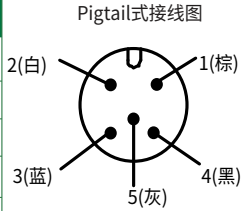

功能	Pigtail式线芯颜色
1 电源正	棕
2 NPN/PNP2	白
3 电源负	蓝
4 NPN/PNP1	黑
5 激光使能输入/置零	灰

接线图 (NPN)

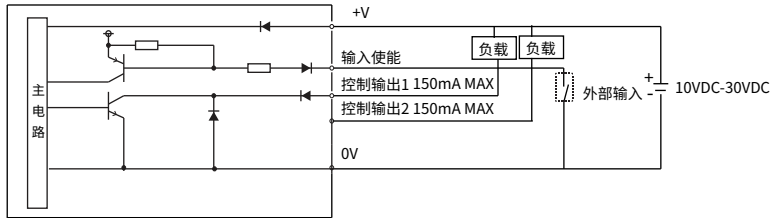

接线图 (PNP)

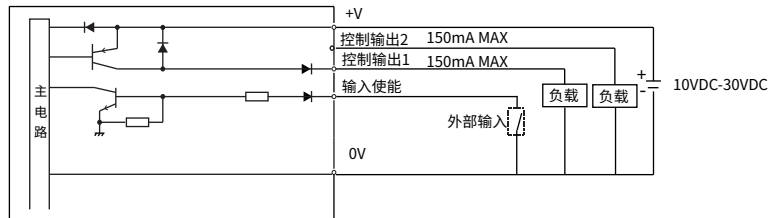

安全注意事项

⚠ 危险	本产品仅用于物体检测。请勿将本产品用于保护人体或人体部位。本产品不得用作防爆产品。请勿在危险场所或可能存在爆炸性气体的环境中使用本产品。本装置控制或调节装置的未使用或未按本规定执行步骤, 可能导致有害辐射暴露。未按照本规定使用控制或调节装置或未执行相应步骤, 可能导致有害辐射暴露。
⚠ 警告	该产品为直流电源传感器。请勿使用交流电源。如接入交流电压, 产品可能会爆炸或起火。
通知	请不要将电源线与高压线路使用同一布线, 否则主模块可能会因噪声而故障或损坏。在使用市售的开关稳压器时, 请确保将外壳接地端子和地线端子接地。请勿在户外使用本产品。

教导模式说明

<p>教导</p> <p>检测模式设定说明: 需事先在Menu中将“检测模式设定”设为对应功能模式。</p>	
<p>1. 通常检测模式 在菜单中, 选定“_ _”模式, 自动进入测量界面; 在有效测量距离内, 选定目标物体(*), 按TEACH键, 提示“GOOD”, 完成设置; 目标物体所在位置即为判定距离。</p>	
<p>2. 1点教导模式 在菜单中, 选定“_N_.1”模式, 先进入窗口大小设置界面; 设置值默认为0.5mm, 按UP/DOWN调整窗口大小设置值, 按TEACH键确认后进入测量界面; 在有效测量距离内, 选定目标物体(*), 按TEACH键, 提示“GOOD”, 完成设置; 目标物体所在位置为中心, 上下加减设置值为窗口, 进行窗口模式判定;</p>	
<p>3. 2点教导模式 在菜单中, 选定“_N_.2”模式, 自动进入测量界面; 在有效测量距离内, 选定目标物体1(*), 按TEACH键, 提示“LP1”, 完成p-1设定; 在有效测量距离内, 选定目标物体2(*), 按TEACH键, 提示“GOOD”, 完成p-2设定; 以目标物体1和目标物体2所在位置之间的距离为窗口, 进行窗口模式判定;</p>	
<p>4. 3点教导模式 在菜单中, 选定“_N_.3”模式, 自动进入测量界面; 在有效测量距离内, 选定目标物体1(*), 按TEACH键, 提示“LP1”, 完成p-1设定; 在有效测量距离内, 选定目标物体2(*), 按TEACH键, 提示“LP2”, 完成p-2设定; 在有效测量距离内, 选定目标物体3(*), 按TEACH键, 提示“GOOD”, 完成p-3设定; 以p-1和p-2的中间距离为窗口边沿1, 以p-2和p-3的中间距离为窗口边沿2, 进行窗口模式判定;</p>	
<p>5. 中点教导模式 在菜单中, 选定“Nid”模式, 自动进入测量界面; 在有效测量距离内, 选定目标物体1(*), 按TEACH键, 提示“LP1”, 完成p-1设定; 在有效测量距离内, 选定目标物体2(*), 按TEACH键, 提示“GOOD”, 完成p-2设定; 以p-1和p-2的中间距离为判定距离;</p>	

*代表微调: 在选定目标物体后, 可通过UP/DOWN键微调目标物体距离, 之后再按TEACH键确定。

INSTRUCTION

1.Menu operation process

STEP

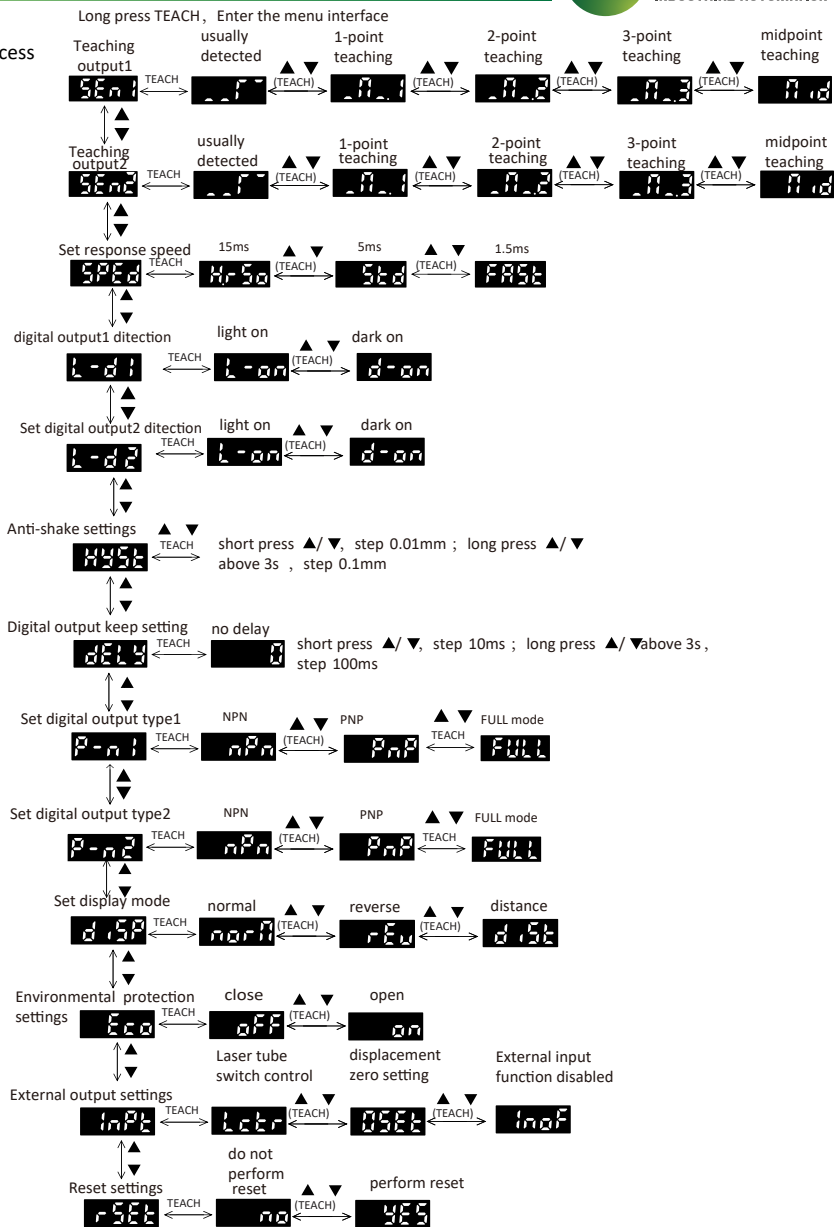

2.Description of button reset function

- 1) Simultaneously press and hold the UP and DOWN keys to reset the button to zero;
- 2) When no reset operation has been performed (key reset operation or external input trigger) and the current display mode is not distance mode, long press and hold the UP and DOWN keys,Then set the current detection position to the displacement zero point, and the red indicator light in the LED display screen remains constant;
- 3) When a reset operation has been performed (key reset operation or external input trigger), long press and hold the UP and DOWN keys again to restore the displacement zero point, and the LED displays the red indicator light in the screen is off;
- 4) When the current display mode is distance mode or the measured value exceeds the actual range of the sensor, long press and hold the UP and DOWN keys, and the LED display screen will display "ErrO";
- 5) When the lock button is turned on, long press and hold the UP and DOWN keys, and the LED display screen will display "Loc";

- 1.Ranging diplay
Measurement interface: Show actual measurement distance, when the distance is out of detected distance,it diplays"-----".
Display description:Take the center distance as 0 point,the distance less than the center is positive,the distance greater than the center is negative,and the displayed value is the offset value.
- 2.Menu and key operation
2.1 Enter the menu: Long pressTEACH above 3s when it is in the measurement interface, enter the menu interface;
Exit menu: Long pressTEACH above 3s when it is in the menu interface, or no key operation for 20s, return to measurement interface.
2.2 Menu operation
Enter the menu interface,diplay the main menu,switch the menu options by pressing the up/down key.
On the main menu interface,enter the submenu options by short pressing TEACH key.Under the submenu,short press up/down to select the parameter.Short press the TEACH key to confirm and return to the previous main menu.
 - 1)Teaching output1
The main menu shows"SEn1", press TEACH to enter the submenu;
Submenu items: "_|" "usually detected mode (default)"; "_N_.1"1-point teaching window comparison mode; "_N_.2"2-point teaching window comparison mode; "_N_.3"3-point teaching window comparison mode. "nid"midpoint teaching mode.
The above teaching modes are detailed in 6.Teaching mode description.
 - 2)Teaching output2
The main menu shows"SEn2", press TEACH to enter the submenu;
Submenu items: "_|" "usually detected mode (default)"; "_N_.1"1-point teaching window comparison mode; "_N_.2"2-point teaching window comparison mode; "_N_.3"3-point teaching window comparison mode. "nid"midpoint teaching mode.
The above teaching modes are detailed in 6.Teaching mode description.
 - 3)Set response speed:
The main menu shows"SPEd", press TEACH to enter the submenu;
Submenu items: "H.rSo"high precision 15ms;"Std"standard 5ms (default) ; "FAST"high speed 1.5ms;
 - 4)Set digital output dtection1
The main menu shows" L-d1", press TEACH to enter the submenu;
Submenu items: "L-on"luminous (default) ; "d-on"dark pass;
 - 5)Set digital output dtection2
The main menu shows" L-d2", press TEACH to enter the submenu;
Submenu items: "L-on"luminous (default) ; "d-on"dark pass;
 - 6)Anti-shake settings
The menu displays "HySt". Press TEACH to enter the submenu.
Submenu initial diplay" 0.1",0.1mm is hysteresis distance, short press UP/DOWN,KL30 step 0.001mm,KL50- KL100 step 0.01mm, KL200- KL400 step 0.1mm;long press UP/DOWN above 3s, KL30 step 0.01mm,KL50- KL100 step 0.1mm,KL200- KL400 step 1mm;
Setting range is 0~5mm,KL30 initial value is 0.01mm, KL50- KL100 initial value is 0.1mm, KL200- KL400 initial value is 1mm;
 - 7)Digital output keep setting
The main menu shows"dELy", press TEACH to enter the submenu;
Submenu initial diplay" 0",no delay, short press UP/DOWN, step 10ms; long press UP/DOWN above 3s, step 100ms. Setting range is 0~1000ms, initial value is 0ms.
 - 8)Set digital output type1
The main menu shows" P-n1", press TEACH to enter the submenu;
Submenu items: "nPn"NPN output mode (default) ; "PnP"PNP output mode ; "PULL" push pull output mode.
 - 9)Set digital output type2
The main menu shows" P-n2", press TEACH to enter the submenu;
Submenu items: "nPn"NPN output mode (default) ; "PnP"PNP output mode ; "PULL" push pull output mode.
 - 10)Set display mode
The main menu shows"diSP", press TEACH to enter the submenu;
Submenu items: "norN"normal displacement mode (default) ; "rEv"reverse displacement mode; "dist"distance mode.
 - 11)Environmental protection settings
The main menu shows" Eco", press TEACH to enter the submenu;
Environmental protection function note: After the function is turned on,the LED will automatically turn off the display in 30s without any button.
 - 12)External output settings
The main menu shows"INPt", press TEACH to enter the submenu;
Submenu items: "InoF"External input function disabled (default) ; "Lctr"laser tube switch control, turn on emission when there is no external input,and stop emission when the external input is low; "OSet"displacement zero setting, external input connected to low level to trigger once, the current detection position is set as the displacement zero point,in this mode, the red indicator light on the display windoe is always on.The restoration of the displacement zero point is triggered again,and the red indicator light is off.
 - 13)Reset settingssthe
The main menu shows"rSEt", press TEACH to enter the submenu;
Submenu items: " no"do not perform reset; " yES" perform reset, restore default settings.
- 2.3 Key lock function
Turn on key lock:In the measurement interface,press the TEACH and UP keys at the same time for more than 3s, the interface displays "Lc.on", and the menu function is invalid at this time.
Turn off the key lock:After the key lock is turned on,press the TEACH and UP keys at the same time for more than 3s, the interface displays "Lc.FA", press the TEACH and UP keys at the same time for more than 3s again, the interface displays "Lc.oF" and the key function are restored.

操作指南

1. 菜单操作流程



2. 按键归零功能说明

- 1) 同时长按UP和DOWN键进行按键归零;
- 2) 当未进行过归零操作(按键归零操作或外部输入触发), 且当前显示模式不为距离模式, 长按UP和DOWN键, 则将当前检测位置设置为位移零点, 此时LED显示屏中红色指示灯常亮;
- 3) 当已进行过归零操作(按键归零操作或外部输入触发), 再次长按UP和DOWN键, 则还原位移零点, LED显示屏中红色指示灯熄灭;
- 4) 当前显示模式为距离模式或测量值超出传感器实际量程时, 长按UP和DOWN键, LED显示屏中将显示“ErrO”;
- 5) 当开启按键锁定时, 长按UP和DOWN键, LED显示屏中将显示“Loc”;

1. 测距显示

测量界面: 显示实际测量距离, 超出检测范围时显示“---”。
显示说明: 以中心距离为0点, 小于中心距离为正, 大于中心距离为负, 显示值为偏移值。

2. 菜单及按键操作

2.1 进入菜单: 测量界面下长按TEACH键3秒以上, 进入菜单界面;
退出菜单: 菜单界面下长按TEACH键3秒以上, 或20秒无按键操作, 返回测量界面。

2.2 菜单操作

进入菜单界面, 显示主菜单; 通过短按UP/DOWN键切换菜单子选项;
主菜单界面, 通过短按TEACH键进入相应的子菜单子选项, 子菜单下, 短按UP/DOWN进行参数选择, 在对应选项下短按TEACH键确认并返回上级主菜单;

1) 教导输出1

主菜单显示“5En1”, 按TEACH进入子菜单。

子菜单项: “ ” 通常检测模式(默认); “_N_1” 1点教导窗口比较模式;
“_N_2” 2点教导窗口比较模式; “_N_3” 3点教导窗口比较模式; “Nid” 中点教导模式。以上教导模式详见6.教导模式说明;

2) 教导输出2

主菜单显示“5En2”, 按TEACH进入子菜单。

子菜单项: “ ” 通常检测模式(默认); “_N_1” 1点教导窗口比较模式;
“_N_2” 2点教导窗口比较模式; “_N_3” 3点教导窗口比较模式; “Nid” 中点教导模式。以上教导模式详见6.教导模式说明;

3) 设定响应速度:

主菜单显示“SPED”, 按TEACH进入子菜单;

子菜单项: “H.rSo” 高精度15ms; “Std” 标准5ms(默认); “FASt” 高速1.5ms;

4) 数字输出方向设定1

主菜单显示“L-d1”, 按TEACH进入子菜单;

子菜单项: “L-on” 亮通(默认); “d-on” 暗通;

5) 数字输出方向设定2

主菜单显示“L-d2”, 按TEACH进入子菜单;

子菜单项: “L-on” 亮通(默认); “d-on” 暗通;

6) 防抖设定

菜单显示“HySt”, 按TEACH进入子菜单。

子菜单初始显示“0.1”, 分辨率0.1mm为迟滞距离, 短按UP/DOWN时, KL30步进距离0.001mm; KL50、KL100步进距离0.01mm; KL200、KL400步进距离0.1mm; 长按UP/DOWN键3s以上, KL30步进距离0.01mm; KL50、KL100步进距离0.1mm; KL200、KL400步进距离1mm; 设置范围0~5mm, KL30初始值0.01mm; KL50、KL100初始值0.1mm; KL200、KL400初始值1mm;

7) 数字输出保持设定

菜单显示“delay”, 按TEACH进入子菜单。

子菜单显示“0”无延迟, 短按UP/DOWN时, 步进距离10ms;

长按UP/DOWN键3s以上, 步进距离100ms。设置范围0~1000ms, 初始值为0ms。

8) 数字输出类型设定1

主菜单显示“P-n1”, 按TEACH进入子菜单。

子菜单项: “nPn” NPN输出模式(默认); “PnP” PNP输出模式; “PULL” 推挽输出模式。

9) 数字输出类型设定2

主菜单显示“P-n2”, 按TEACH进入子菜单。

子菜单项: “nPn” NPN输出模式(默认); “PnP” PNP输出模式; “PULL” 推挽输出模式。

10) 设定显示模式

菜单显示“diSP”, 按TEACH进入子菜单。

子菜单项: “norN” 正常位移模式(默认); “rEv” 反转位移模式; “dist” 距离模式。

11) 环保设定

菜单显示“Eco”, 按TEACH进入子菜单。

环保功能说明: 该功能打开后, 30s无按键自动熄灭Led显示。

12) 外部输入设定

菜单显示“InPt”, 按TEACH进入子菜单。

子菜单项: “InoF” 外部输入功能禁止(默认); “Lctr” 激光管开光控制, 无外部输入时开启投光, 外部输入为低时停止投光; “OSet” 位移零点设置, 外部输入接低电平触发一次, 则将当前检测位置设置为位移零点, 此模式显示窗红色指示灯常亮, 再次触发还原位移零点, 指示灯灭。

13) 复位设定

菜单显示“rSet”, 按TEACH进入子菜单。

子菜单项: “no” 不执行复位; “yES” 执行复位, 恢复默认设置。

2.3 按键锁定功能

开启按键锁定: 测量界面下, 同时按下TEACH和UP键3秒以上, 界面显示“Lc.on”, 此时菜单功能失效;

关闭按键锁定: 按键锁定开启后, 同时按下TEACH和UP键3秒以上, 界面显示“Lc.FA”, 再次同时按下TEACH和UP键3秒以上, 界面显示“Lc.oF”, 按键功能恢复。

DIGITAL TUBE DISPLAY INTERPRETATION

SEN5	sens	teaching output
_m	_m	usually detected
_m_1	_m_1	1-point teaching
_m_2	_m_2	2-point teaching
_m_3	_m_3	3-point teaching
_mid	_mid	midpoint teaching
SPED	sped	set response speed
H-50	h.ros	high precision
50	std	standard
FAST	fast	high speed
L-d	l-d	set switch output detection
L-on	l-on	luminous
d-on	d-on	dark pass
HYST	hyst	anti-shake settings
dely	dely	switch output keep settings
0	0	no delay
P-n	p-n	set switch output
nPN	nPN	NPN
pNP	pNP	PNP
ao-f	ao-f	reverse
ao-r	ao-r	forward
FULL	full	full scale
rANG	rANG	window mode(corresponding to two-point teaching mode)
disp	disp	set display mode
norm	norm	normal displacement mode
rev	rev	reverse displacement mode
dist	dist	distance mode
eco	eco	environmental protection settings
off	off	environmental protection close
on	on	environmental protection open
inpt	inpt	external output settings
inof	inof	external input function disabled
lctr	lctr	laser tube switch control
0set	0set	displacement zero setting
rest	rest	reset settings
no	no	do not perform reset
yes	yes	perform reset

INSTALLATION DIAGRAM

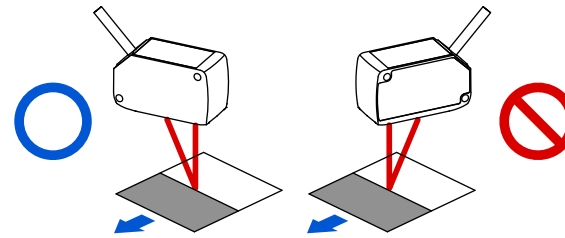

1. In the case of color or material difference
When the material or color of moving object is extremely different, install it in the direction shown on the left to keep the measurement error to a minimum.

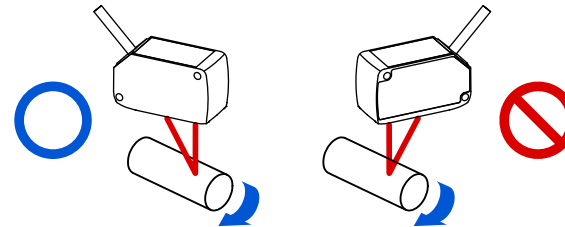

2. Detect rotating objects
When detecting a rotating object, install it in the direction shown on the left, which can suppress the influence of the object's vertical vibration and position shift.

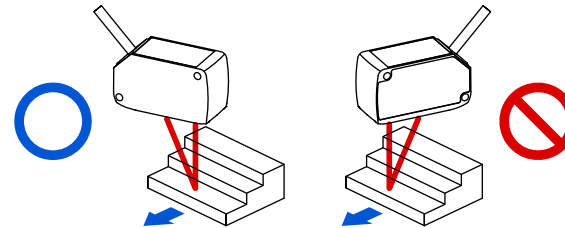

3. When there is a step
If there is a step in the moving detection object, install it according to the method shown on the left, so as to suppress the influence of the step edge during measurement.

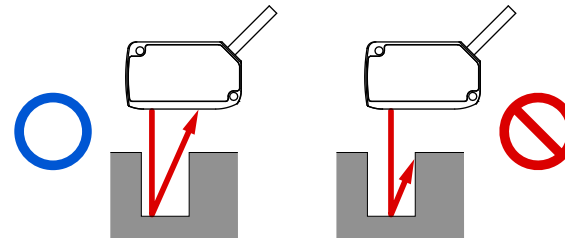

4. Measure in narrow places and recessed parts
In the case of measuring in a narrow place or hole, please be careful not to block the light path from the light emitting part to the light receiving part when installing.

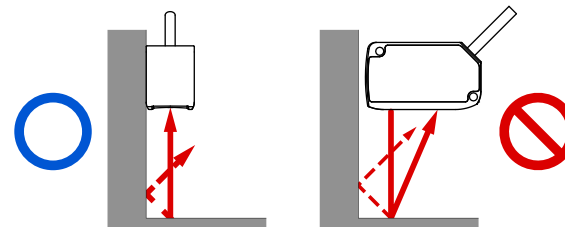

5. When installed on the wall
Please install according to the method shown on the left to avoid the multiple reflected light from the wall entering the light receiving part.

数码管显示释义

SENS	sens	教导输出
_m	_m	通常检测
_m_1	_m_1	1点教导
_m_2	_m_2	2点教导
_m_3	_m_3	3点教导
_mid	_mid	中点教导
SPED	sped	设定响应速度
H-50	h.ros	高精度速度15ms
5td	std	标准速度5ms
FAST	fast	高速1.5ms
L-d	l-d	设定开关量输出方向
L-on	l-on	亮通
d-on	d-on	暗通
HYST	hyst	防抖设定
dely	dely	开关量输出保持设定
0	0	无延迟
P-n	p-n	设定开关量输出类型
nPN	nPN	NPN输出模式
pnp	pnp	PNP输出模式
ao-f	ao-f	正向
ao-r	ao-r	反向
FULL	full	全程模式
rANG	rang	窗口模式 (对应两点教导模式)
disp	disp	设定显示模式
norm	norm	正常位移模式
rev	rev	反转位移模式
dist	dist	距离模式
eco	eco	环保设定
off	off	环保关
on	on	环保开
inpt	inpt	外部输入设定
inof	inof	外部输入功能静止
lctr	lctr	激光管开关控制
0set	0set	位移零点设置
rest	rest	复位设定
no	no	不执行复位
yes	yes	执行复位

安装示意图

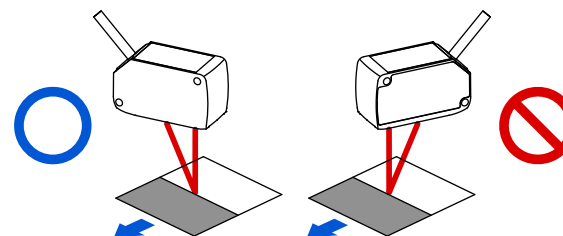

1.材质、有色差的情况下测量时，移动的测量对象物的材质、颜色极端不同的情况下，按照左图所示方向进行安装，从而可将测量误差控制在最小限度。

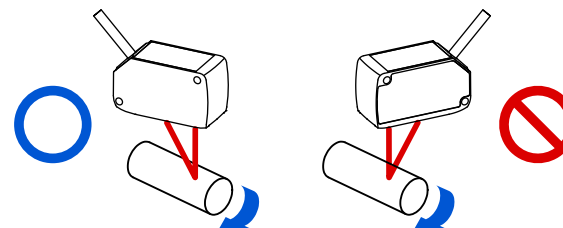

2.对旋转的对象物进行检测
对旋转的对象物进行检测时，按照左图所示方向进行安装，从而可抑制对象物的上下振动和位置偏移等的影响。

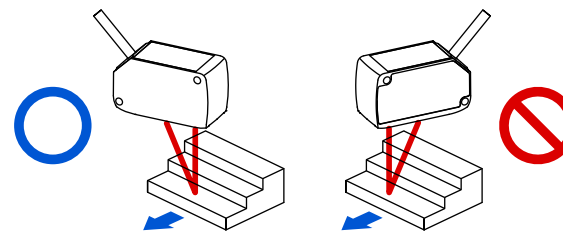

3.存在段差的情况下
移动的检测对象物存在段差的情况下，请按照左图所示方法进行安装，从而可在测量时抑制段差边缘所产生的影响。

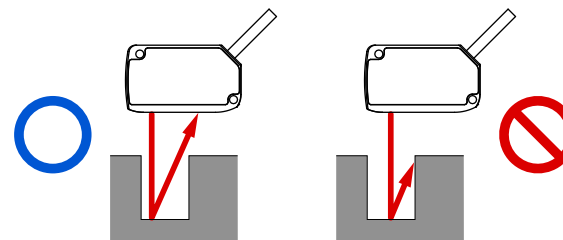

4.在狭窄场所和凹陷部分进行测量
在狭窄场所和孔中进行测量的情况下，安装时，请注意避免遮挡投光部至受光部的光路。

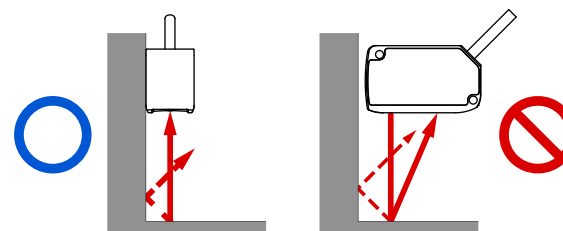

5.安装在墙上时
请按照左图所示方法进行安装，以免墙面产生的多重反射光入光到受光部分。另外墙面反射率较高的情况下，如改成无光泽的黑色，则效果更好。