

Product Description

- Laser displacement sensor ,655nm laser source,FULL Metal JACKET,durable,better protective performance,small light spot,high precision,LED display and key setting,displacement ranging from 50 mm to 400 mm center point.
- Suitable for dispensing machine,packing,automobile AGV and other industries.



Product features:

- Short,medium and long distances are available.
- Support switch output,NPN/PNP can be set.
- Support RS485 output
- Support ECO mode setting.
- Four white digital tubes,clear and bright
- Strong ambient light resistance and compact size
- Support multiple detection modes,multi-scene applications.



TECHNICAL SPECIFICATION

OPERATING VOLTAGE	10...30 V DC , Class 2	WORKING TEMPERATURE	-10°C ... +50°C
POWER SUPPLY	<1W	AMBIENT ILLUMINANCE	Under 3000lux
LIGHT SOURCE TYPE	Laser class 2, 655 nm	PROTECTION DEGREE	IP67
CONTROL OUTPUT	NPN/PNP can be set	HOUSING MATERIAL	Die-cast zinc
RS485 OUTPUT	Modbus protocol TIA/EIA-485A standard	WINDOWS MATERIAL	Glass
RESPONSE TIME	15ms/5ms/1.5ms	CONNECTIONS	Cable/Pigtail Cable
		LASER LABEL	pastng on packing bag
		MAINTAIN	disassemble; please return to ELCO
		MAXIMUM HUMIDITY	Max.85%Rh
		ALTITUDE	Up to 2000m
		POLLUTION DEGREE	3

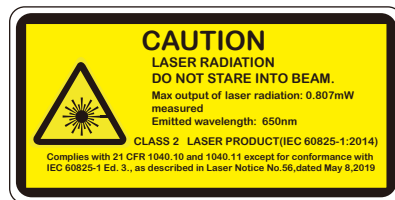

DIMENSIONS

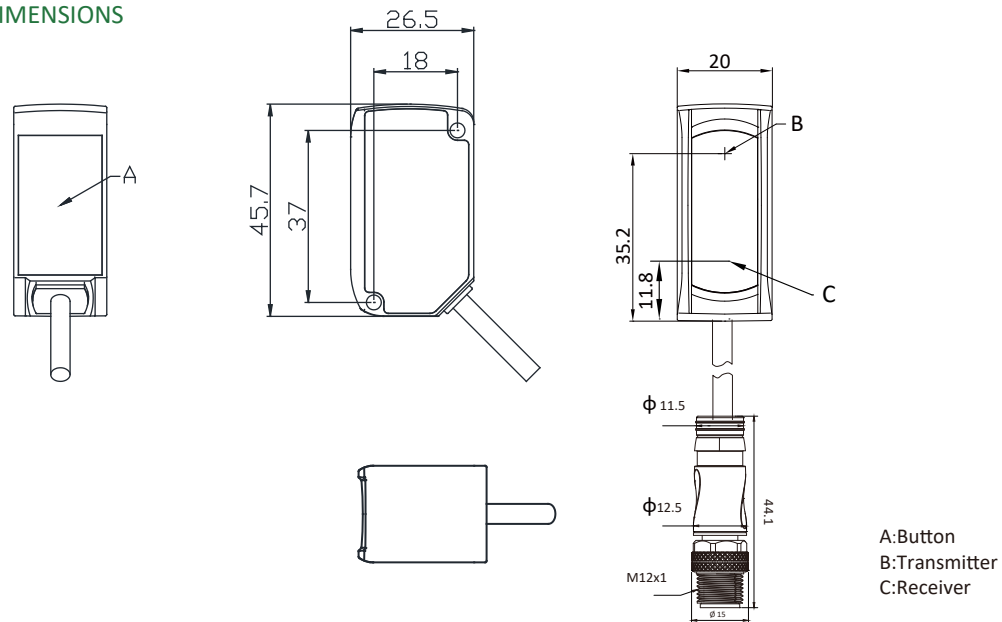

Type	Measurement range	Measurement center distance	Beam diameter	Repeatability	Linearity	Resolution
OSM41-KL30CB6/485*M	25...35mm	30mm	0.2mm @50mm	10µm	±0.1%F.S.	0.001mm
OSM41-KL30CB6/485-* -Q12.1						
OSM41-KL50CB6/485*M	35...65mm	50mm	0.5mm @50mm	30µm	±0.1%F.S.	0.01mm
OSM41-KL50CB6/485-* -Q12.1						
OSM41-KL100CB6/485*M	65...135mm	100mm	0.5mm @100mm	70µm	±0.1%F.S.	0.01mm
OSM41-KL100CB6/485-* -Q12.1						
OSM41-KL200CB6/485*M	120...280mm	200mm	1mm @200mm	200µm	±0.2%F.S.	0.1mm
OSM41-KL200CB6/485-* -Q12.1						
OSM41-KL400CB6/485*M	200...600mm	400mm	1mm @150mm 2mm @600mm	0.5mm(≤400mm) 1mm(≤600mm)	±0.2%F.S.(≤400mm) ±0.3%F.S.(≤600mm)	0.1mm
OSM41-KL400CB6/485-* -Q12.1						
OSM41-KL1500CB6/485*M	150 ...1500mm	400mm	1mm@200mm 2mm@600mm	0.3mm (200mm~400mm)	±0.2%F.S. (200mm~400mm)	1mm
OSM41-KL1500CB6/485-* -Q12.1				0.8mm (400mm~600mm)	±0.3%F.S. (400mm~600mm)	

Note 1: This product is a laser product, which can be used after 10 minutes of preheating after power-on.

Note 2: For breakout products, *M represents the cable length; if not specified, the default is 2 meters.

For pigtail products, * represents the cable length in meters. If there is no Wei connector product

We reserve the right to make technical alterations without prior notice. | EN & CN | Creation date: 25.12.08 | UM_SP_OSM41-485_V1.0_EN&CN

产品说明:

- 激光位移传感器, 655nm激光光源, 全金属外壳, 坚固耐用, 防护性能更好, 体积小, 光斑小, 精度高, LED显示和按键设置, 50mm~400mm中心点的位移型测距。适用点胶机、包装、汽车、AGV等行业应用。

产品特点:

- 短、中、长三种检测距离可选
- 支持开关量输出, NPN/PNP可设定
- 支持RS485输出
- 支持ECO模式设定
- 四位白色数码管, 明亮清晰
- 抗环境光能力强, 紧凑尺寸
- 支持多种检测模式, 多场景应用



型号	检测距离	测量中心距离	光束直径	重复精度	线性度	分辨率
OSM41-KL30CB6/485*M	25...35mm	30mm	0.2mm@50mm	10μm	±0.1%F.S.	0.001mm
OSM41-KL30CB6/485-* -Q12.1						
OSM41-KL50CB6/485*M	35...65mm	50mm	0.5mm@50mm	30μm	±0.1%F.S.	0.01mm
OSM41-KL50CB6/485-* -Q12.1						
OSM41-KL100CB6/485*M	65...135mm	100mm	0.5mm@ 100mm	70μm	±0.1%F.S.	0.01mm
OSM41-KL100CB6/485-* -Q12.1						
OSM41-KL200CB6/485*M	120...280mm	200mm	1mm@200mm	200μm	±0.2%F.S.	0.1mm
OSM41-KL200CB6/485-* -Q12.1						
OSM41-KL400CB6/485*M	200...600mm	400mm	1mm@150mm 2mm@600mm	0.5mm(≤400mm) 1mm(≤600mm)	±0.2%F.S.(≤400mm) ±0.3%F.S.(≤600mm)	0.1mm
OSM41-KL400CB6/485-* -Q12.1						
OSM41-KL1500CB6/485*M	150 ...1500mm	400mm	1mm@200mm 2mm@600mm	0.3mm (200mm~400mm) 0.8mm (400mm~600mm) 2mm (600mm~800mm) 5mm (800mm~1500mm)	±0.2%F.S. (200mm~400mm) ±0.3%F.S. (400mm~600mm) ±0.5%F.S. (600mm~1500mm)	1mm
OSM41-KL1500CB6/485-* -Q12.1						

注1: 本产品为激光类产品, 上电预热十分钟后使用。

注2: 出线产品*M代表线长, 如无为默认2M长度。pigtail产品*代表线长, 单位为米, 若无为接插件产品。

技术参数

工作电压	10...30VDC, Class2	工作温度	90D
功率	<1W	环境照度	3000lux
光源	激光 II 级, 655nm	防护等级	IP67
控制输出	NPN/PNP可选	外壳	压铸锌
RS485输出	modbus协议 TIA/EIA-485A标准	窗口	玻璃
反应时间	15ms/5ms/1.5ms可选	连接形式	线缆式/pigtail线缆
		激光标签	包装袋粘贴
		维护信息	异常返厂宜科处理
		最高湿度	最高85%相对湿度
		海拔	高达2000米
		污染程度	三级

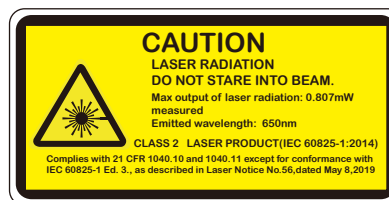

外型尺寸

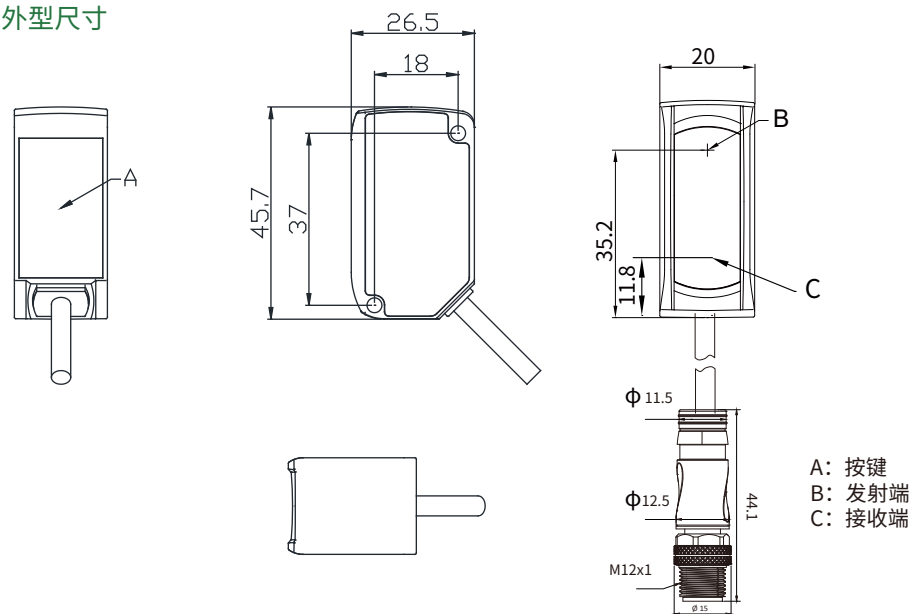

A: 按键
B: 发射端
C: 接收端

INTERFACE DEFINITION AND WIRING DIAGRAM

	Function	Cabel product core color
1	Positive power supply	Brown
2	485B	Gray
3	Power negative	Blue
4	NPN/PNP	Black
5	485A	Pink

Connector wiring diagram

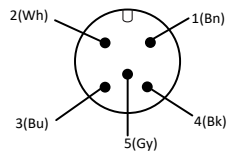

	Function	Connector product core color
1	Positive power supply	Brown
2	485B	Gray
3	Power negative	Blue
4	NPN/PNP	Black
5	485A	Pink

Wiring diagram (NPN)

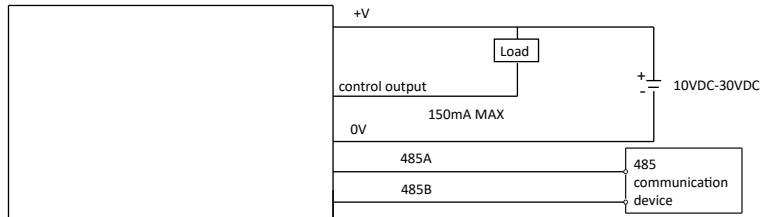

Wiring diagram (PNP)

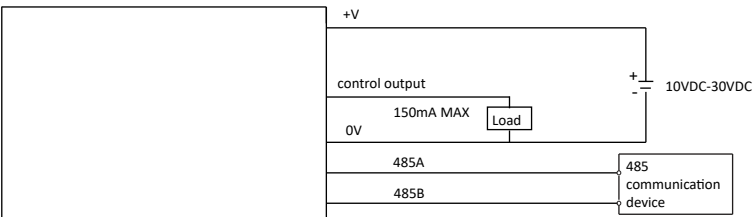

SAFETY PRECAUTIONS

⚠ DANGEROUS	<p>This product is for the purpose of object detection only. Do not use this product for the purpose of protecting human body or human body parts. This product should not be used as an explosion-proof product. Do not use this product in dangerous places or in the environment of potentially explosive gases.</p> <p>Failure to use the control or adjustment device or perform the steps in accordance with this regulation may result in harmful radiation exposure.</p> <p>Ce produit est à des fins de détection d'objets seulement. N'utilisez pas ce produit dans le but de protéger le corps humain ou des parties du corps humain. Ce produit ne doit pas être utilisé comme produit antidéflagrant. Ne pas utiliser ce produit dans des endroits dangereux ou dans l'environnement de gaz potentiellement explosifs.</p> <p>La non-utilisation du dispositif de commande ou de réglage ou l'exécution des étapes conformément au présent règlement peut entraîner une exposition aux rayonnements nocifs.</p>
⚠ WARN	<p>This product is a sensor with DC power supply. Please do not apply AC power supply. If AC voltage applied, the product may explode or catch fire.</p> <p>Ce produit est un capteur avec alimentation cc. Veuillez ne pas appliquer d'alimentation en courant alternatif. En cas de tension, le produit peut exploser ou prendre feu.</p>
NOTICE	<p>Do not use the same wiring with the power cord and high-voltage line, otherwise the main module may fail or be damaged due to noise. When using a commercially available switching regulator, be sure to ground the housing ground terminal and the ground terminal.</p> <p>Please do not use this product outdoors.</p> <p>N'utilisez pas le même câblage avec le cordon d'alimentation et la ligne à haute tension, sinon le module principal peut tomber en panne ou être endommagé en raison du bruit. Lorsque vous utilisez un régulateur de commutation disponible dans le commerce, assurez-vous de mettre à la terre le terminal d'habitation et le terminal de terre. Veuillez ne pas utiliser ce produit à l'extérieur.</p>

TEACHING MODE DESCRIPTION

Teach

Detection mode setting description:
It is necessary to set the "Detection Mode Setting" in the menu to the corresponding function mode in advance.

1. Normal detection mode
In the menu, select the "□" mode, automatically enter the detection interface; Select the target object(*) within the effective detection distance and press the TEACH key, and prompt "GOOD" to complete the setting. The location of the target object is the judgement distance.

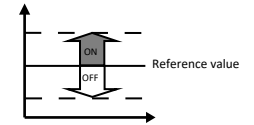

2. 1-point teaching window comparison mode
In the menu, select the "_N_1" mode, first enter the window size setting interface; The default setting value is 0.5mm, press UP/DOWN to adjust the window size setting value. Press the TEACH key to enter the measurement interface; within the effective measurement distance, select the target object(*), press TEACH key, prompt "GOOD", complete the setting. The position of the target object is the center, plus and minus setting value as window edge, and perform window mode judgement.

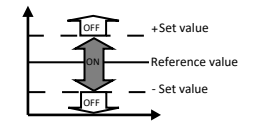

3. 2-point teaching window comparison mode
In the menu, select the "_N_2" mode, automatically enter the measurement interface. Select the target object 1(*) within the effective detection distance and press the TEACH key, and prompt "LP1" to complete p-1 setting. Select the target object 2(*) within the effective detection distance and press TEACH key, prompt "GOOD" to complete the p-2 setting. Use the distance between the location of target object 1 and target object 2 as the window to determine the window mode.

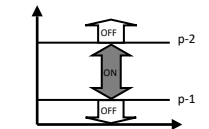

4. 3-point teaching window comparison mode
In the menu, select the "_N_3" mode, automatically enter the measurement interface. Select the target object 1(*) within the effective detection distance and press the TEACH key, and prompt "LP1" to complete p-1 setting. Select the target object 2(*) within the effective detection distance and press TEACH key, prompt "LP2" to complete the p-2 setting. Select the target object 3(*) within the effective detection distance and press TEACH key, prompt "GOOD" to complete the p-3 setting. Take the middle distance between p-1 and p-2 as window edge 1, and the middle distance between p-2 and p-3 as window edge 2, and perform window mode judgement.

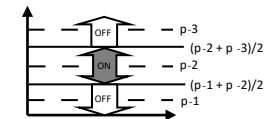

5. midpoint teaching mode
In the menu, select the "Nid" mode, automatically enter the measurement interface. Select the target object 1(*) within the effective detection distance and press the TEACH key, and prompt "LP1" to complete p-1 setting. Select the target object 2(*) within the effective detection distance and press TEACH key, prompt "GOOD" to complete the p-2 setting. Take the middle distance between p-1 and p-2 as the judgement distance.

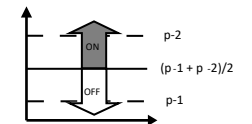

*Represents fine adjustment: After selecting the target object, you can fine-tune the distance of the target object with the UP/DOWN key, and then press the TEACH key to confirm.

接口定义和接线图

功能	出线式线芯颜色
1 电源正	棕
2 485B	灰
3 电源负	蓝
4 NPN/PNP	黑
5 485A	粉

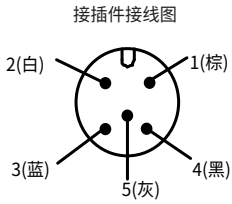

功能	接插件式线芯颜色
1 电源正	棕
2 485B	白
3 电源负	蓝
4 NPN/PNP	黑
5 485A	灰

接线图 (NPN)

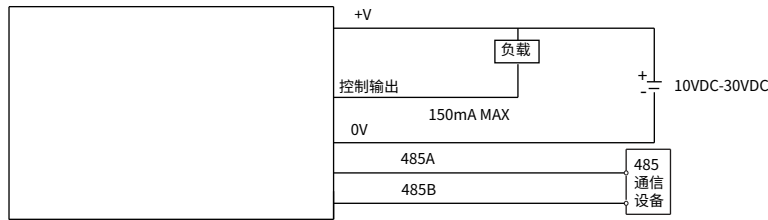

接线图 (PNP)

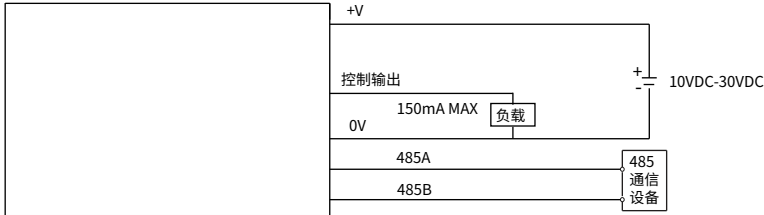

安全注意事项

⚠ 危险	本产品仅用于物体检测。请勿将本产品用于保护人体或人体部位。本产品不得用作防爆产品。请勿在危险场所或可能存在爆炸性气体的环境中使用本产品。本装置控制或调节装置的未使用或未按本规定执行步骤，可能导致有害辐射暴露。未按照本规定使用控制或调节装置或未执行相应步骤，可能导致有害辐射暴露。
⚠ 警告	该产品为直流电源传感器。请勿使用交流电源。如接入交流电压，产品可能会爆炸或起火。
📢 通知	请不要将电源线与高压线路使用同一布线，否则主模块可能会因噪声而故障或损坏。在使用市售的开关稳压器时，请确保将外壳接地端子和地线端子接地。请勿在户外使用本产品。

教导模式说明

<p>教导</p> <p>检测模式设定说明： 需事先在Menu中将“检测模式设定”设为对应功能模式。</p>	
<p>1. 通常检测模式</p> <p>在菜单中，选定“_1_”模式，自动进入测量界面；在有效测量距离内，选定目标物体(*)，按TEACH键，提示“GOOD”，完成设置；目标物体所在位置即为判定距离。</p>	
<p>2. 1点教导模式</p> <p>在菜单中，选定“_N_1_”模式，先进入窗口大小设置界面；设置值默认为0.5mm，按UP/DOWN调整窗口大小设置值，按TEACH键确认后进入测量界面；在有效测量距离内，选定目标物体(*)，按TEACH键，提示“GOOD”，完成设置；目标物体所在位置为中心，上下加减设置值为窗口，进行窗口模式判定；</p>	
<p>3. 2点教导模式</p> <p>在菜单中，选定“_N_2_”模式，自动进入测量界面；在有效测量距离内，选定目标物体1(*)，按TEACH键，提示“LP1”，完成p-1设定；在有效测量距离内，选定目标物体2(*)，按TEACH键，提示“GOOD”，完成p-2设定；以目标物体1和目标物体2所在位置之间的距离为窗口，进行窗口模式判定；</p>	
<p>4. 3点教导模式</p> <p>在菜单中，选定“_N_3_”模式，自动进入测量界面；在有效测量距离内，选定目标物体1(*)，按TEACH键，提示“LP1”，完成p-1设定；在有效测量距离内，选定目标物体2(*)，按TEACH键，提示“LP2”，完成p-2设定；在有效测量距离内，选定目标物体3(*)，按TEACH键，提示“GOOD”，完成p-3设定；以p-1和p-2的中间距离为窗口边沿1，以p-2和p-3的中间距离为窗口边沿2，进行窗口模式判定；</p>	
<p>5. 中点教导模式</p> <p>在菜单中，选定“_Nid_”模式，自动进入测量界面；在有效测量距离内，选定目标物体1(*)，按TEACH键，提示“LP1”，完成p-1设定；在有效测量距离内，选定目标物体2(*)，按TEACH键，提示“GOOD”，完成p-2设定；以p-1和p-2的中间距离为判定距离；</p>	

*代表微调：在选定目标物体后，可通过UP/DOWN键微调目标物体距离，之后再按TEACH键确定。

INSTRUCTION

1.Menu operation process

STEP

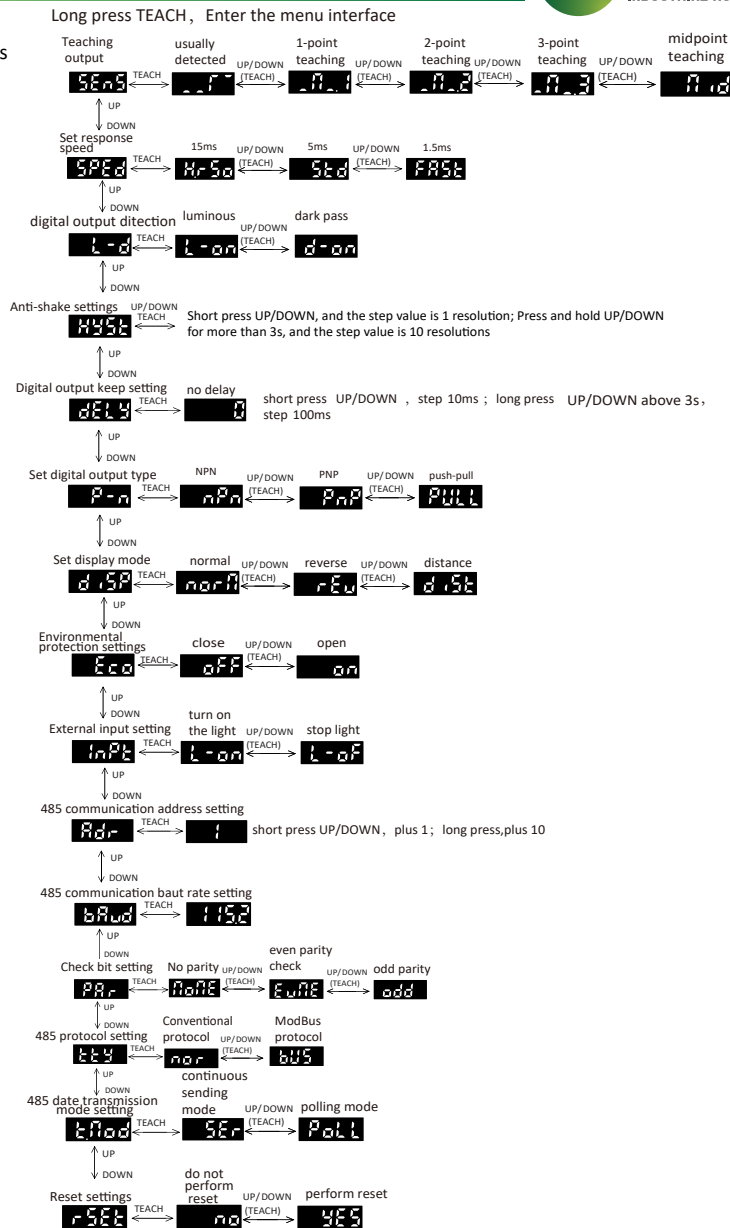
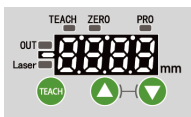

2.Description of button reset function

- 1) Simultaneously press and hold the UP and DOWN keys to reset the button to zero;
- 2) When no reset operation has been performed (key reset operation or external input trigger) and the current display mode is not distance mode, long press and hold the UP and DOWN keys,Then set the current detection position to the displacement zero point, and the red indicator light in the LED display screen remains constant;
- 3) When a reset operation has been performed (key reset operation or external input trigger), long press and hold the UP and DOWN keys again to restore the displacement zero point, and the LED displays The red indicator light in the screen is off;
- 4) When the current display mode is distance mode or the measured value exceeds the actual range of the sensor, long press and hold the UP and DOWN keys, and the LED display screen will display "Err0";
- 5) When the lock button is turned on, long press and hold the UP and DOWN keys, and the LED display screen will display "Loc";

3.Ranging diplay

Measurement interface: Show actual measurement distance, when the distance is out of detected distance,it diplays"----".

4.Menu and key operation

- 4.1 Enter the menu: Long pressTEACH above 3s when it is in the measurement interface, enter the menu interface;
- 4.2 Exit menu: Long presTEACH above 3s when it is in the menu interface, or no key operation for 20s, return to measurement interface.

4.2 Menu operation

Enter the menu interface,diplay the main menu,switch the menu options by pressing the up/down key. On the main menu interface,enter the submenu options by short pressing TEACH key.Under the submenu,short press up/down to select the parameter.Short press the TEACH key to confirm and return to the previous main menu.

1)Teaching output

The main menu shows"SEN5", press TEACH to enter the submenu;Submenu items: "___"usually detected mode (default); "_N_1"1-point teaching window comparison mode; "_N_2"2-point teaching window comparison mode; "_N_3"3-point teaching window comparison mode. "nid"midpoint teaching mode.

The above teaching modes are detailed in 6.Teaching mode description.

2)Set response speed:

The main menu shows"SPEd", press TEACH to enter the submenu; Submenu items: "H.rSo"high precision 15ms;"Std"standard 5ms (default); "FASt"high speed 1.5ms;

3)Set digital output dtection

The main menu shows" L-d", press TEACH to enter the submenu;Submenu items: "L-on"luminous (default); "d-on"dark pass;

4)Anti-shake settings

The menu displays "HySt". Press TEACH to enter the submenu. The initial display resolution of the submenu * 10 is the hysteresis distance. When pressing UP/DOWN briefly, the step distance is 1 resolution;Press and hold the UP/DOWN key for more than 3s, and the step distance is 10 resolutions.

5)Digital output keep setting

The main menu shows"dELy", press TEACH to enter the submenu; Submenu initial diplay" 0",no delay, short press UP/DOWN, step 10ms; long press UP/DOWN above 3s, step 100ms. Setting range is 0~1000ms, initial value is 0ms.

6)Set digital output type

The main menu shows" P-n", press TEACH to enter the submenu; Submenu items: "nPn"NPN output mode (default); "PnP"PNP output mode."PULL"push-pull output mode.

7)Set display mode

The main menu shows"diSP",press TEACH to enter the submenu; Submenu items: "norN"normal mode; "rEv"reverse; "diSt"distance mode; Factory default distance mode.

8)Environmental protection settings

The main menu shows" Eco", press TEACH to enter the submenu; Environmental protection function note: After the function is turned on,the LED will automatically turn off the display in 30s without any button.

9)External output settings

The main menu shows" InPt", press TEACH to enter the submenu; Submenu items: "L-on"turn on emission (default); "L-oF"stop emission;

10)485 communication address setting

The main menu shows" Adr", press TEACH to enter the submenu; Submenu items: " 1", short press UP/DOWN, plus 1; long press for 3s,plus 10. Press TEACH,return to the previous menu. Setting range:0~255. Initial address is 0, 255 is broadcast address.

11)485 communication baut rate setting

The main menu shows"bAud", press TEACH to enter the submenu; Submenu items: "115.2", press UP/DOWN adjustment parameters, the baut rate setting contains the following options, 2400、4800、9600、19200、38400、115200bit/s, unit is Kbit/s.

12)Check bit setting

The menu shows"PAR" and press TEACH to enter the submenu Sub-menu item: "NoNE" without verification mode (default): "EuEN" parity check: odd check Under the submenu, press UP/DOWN to make a selection, and press the TEACH key to confirm and return to the superior menu. Note: The default is "NoNE" without verification mode;

13)485 protocol setting

The menu shows"tTy" and press TEACH to enter the submenu Sub-menu item: "nor" general mode (default):"bus Mod Bus protocol Under the submenu, press UP/DOWN to make a selection, and press the TEACH key to confirm and return to the superior menu. Note: The default is "nor" normal mode;

14)485 date transmission mode setting

The main menu shows"t.Nod", press TEACH to enter the submenu; Submenu items: "PoLL"polling mode (default); "SEr"continuous sending mode. Press UP/DOWN to choose, press TEACH to confirm and enter the submenu.

Default is" POLL"polling mode, command and control the sensor, if you need to send distance data after power-on, you need switch it to continuous sending mode.

15)Reset settingsthe

The main menu shows"rSet", press TEACH to enter the submenu; Submenu items: " no"do not perform reset; " YES" perform reset, restore default settings.

5. Key lock function

- Turn on key lock:In the measurement interface,press the TEACH and UP keys at the same time for more than 3s, the interface displays "Lc.on", and the menu function is invalid at this time.
- Turn off the key lock:After the key lock is turned on,press the TEACH and UP keys at the same time for more than 3s, the interface displays "Lc.FA", press the TEACH and UP keys at the same time for more than 3s again, the interface displays "Lc.oF" and the key function are restored.

操作指南

1. 菜单操作流程

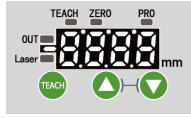

长按TEACH，进入菜单界面

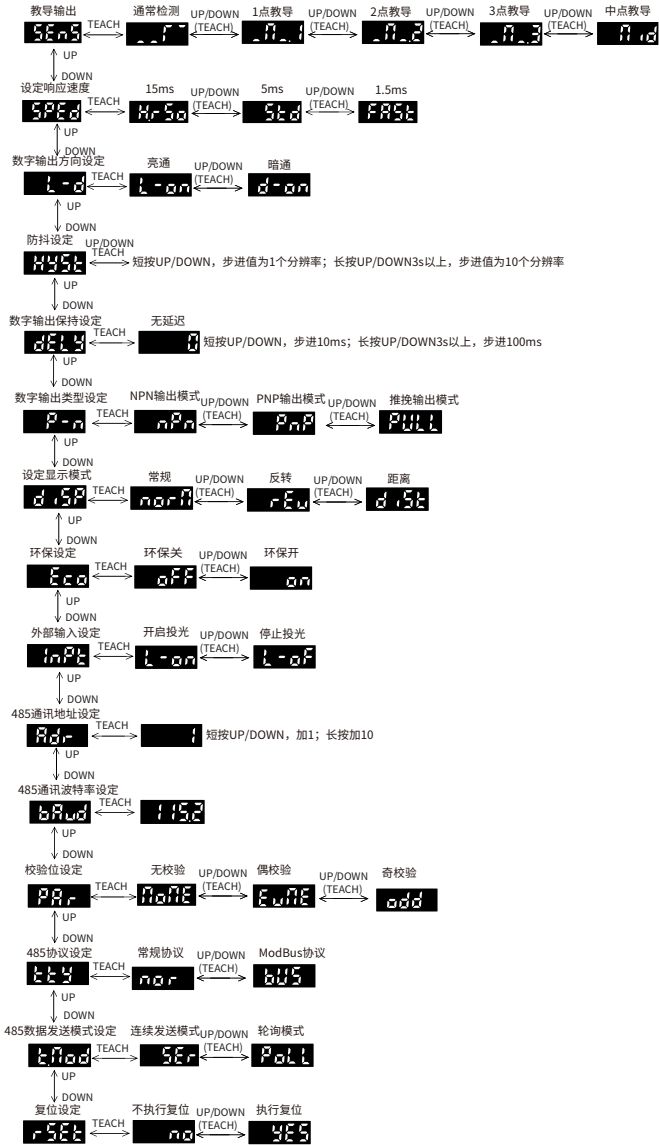

2. 按键归零功能说明

- 1) 同时长按UP和DOWN键进行按键归零；
- 2) 当未进行过归零操作(按键归零操作或外部输入触发)，且当前显示模式不为距离模式，长按UP和DOWN键，则将当前检测位置设置为位移零点，此时LED显示屏中红色指示灯常亮；
- 3) 当已进行过归零操作(按键归零操作或外部输入触发)，再次长按UP和DOWN键，则还原位移零点，LED显示屏中红色指示灯熄灭；
- 4) 当前显示模式为距离模式或测量值超出传感器实际量程时，长按UP和DOWN键，LED显示屏中将显示“ErrO”；
- 5) 当开启按键锁定时，长按UP和DOWN键，LED显示屏中将显示“Loc”；

3. 测距显示

测量界面：显示实际测量距离，分辨率见型号说明，超出检测范围时显示“---”。

4. 菜单及按键操作

- 4.1 进入菜单：测量界面下长按TEACH键3秒以上，进入菜单界面；
- 退出菜单：菜单界面下长按TEACH键3秒以上，或20秒无按键操作，返回测量界面。

4.2 菜单操作

进入菜单界面，显示主菜单；通过短按UP/DOWN键切换菜单选项；主菜单界面，通过短按TEACH键进入相应的子菜单选项，子菜单下，短按UP/DOWN进行参数选择，在对应选项下短按TEACH键确认并返回上级主菜单；

1) 教导输出

主菜单显示“SEnS”，按TEACH进入子菜单。

子菜单项：“ ” 通常检测模式（默认）；“N_1” 1点教导窗口比较模式；“N_2” 2点教导窗口比较模式；“N_3” 3点教导窗口比较模式；“Ni” 中点教导模式。

以上教导模式详见6.教导模式说明；

2) 设定响应速度

主菜单显示“SPEd”，按TEACH进入子菜单；

子菜单项：“H.rSo” 高精度15ms；“Std” 标准5ms（默认）；“FAST” 高速1.5ms；

3) 数字输出方向设定

主菜单显示“L-d”，按TEACH进入子菜单；

子菜单项：“L-on” 亮通（默认）；“d-on” 暗通；

4) 防抖设定

菜单显示“HySt”，按TEACH进入子菜单。

子菜单初始显示分辨率*10为迟滞距离，短按UP/DOWN时，步进距离为1个分辨率；长按UP/DOWN键3s以上，步进距离为10个分辨率。

5) 数字输出保持设定

菜单显示“delay”，按TEACH进入子菜单。

子菜单显示“0” 无延迟，短按UP/DOWN时，步进距离10ms；

长按UP/DOWN键3s以上，步进距离100ms。设置范围0~1000ms，初始值为0ms。

6) 数字输出类型设定

主菜单显示“P-n”，按TEACH进入子菜单。

子菜单项：“nPn” NPN输出模式（默认）；“PnP” PNP输出模式；“PULL” 推挽输出模式。

7) 设定显示模式

菜单显示“diSP”，按TEACH进入子菜单。

子菜单项：“norN” 正常位移模式；“rEv” 反转移模式；“dist” 距离模式，出厂设置默认距离模式。

8) 环保设定

菜单显示“Eco”，按TEACH进入子菜单。

环保功能说明：该功能打开后，30s无按键自动熄灭Lcd显示。

9) 外部输入设定

菜单显示“InPt”，按TEACH进入子菜单。

子菜单项：“L-on” 开启投光（默认）；“L-oF” 停止投光；

10) 485通讯地址设定

菜单显示“Adr”，按TEACH进入子菜单。

子菜单初始显示“1”，按UP/DOWN调整参数，步进1。长按UP/DOWN键3s以上，步进10。

按TEACH键确认并返回上级菜单。设置范围0~255。初始地址为0，255为广播地址。

11) 485通讯波特率设定

菜单显示“bAud”，按TEACH进入子菜单。

子菜单初始显示“115.2”，按UP/DOWN调整参数，波特率设置包含以下选项，

2400、4800、9600、19200、38400、115200bit/s，菜单显示单位为Kbit/s。

12) 校验位设定

菜单显示“PAR”，按TEACH进入子菜单。

子菜单项：“NoNE” 无校验模式（默认）；“EuNE” 偶校验；“odd” 奇校验。

在子菜单下，按UP/DOWN进行选择，按TEACH键确认并返回上级菜单。

注：默认为“NoNE” 无校验模式。

13) 485协议设定

菜单显示“tty”，按TEACH进入子菜单。

子菜单项：“Nor” 常规模式（默认）；“bus” ModBus协议。

在子菜单下，按UP/DOWN进行选择，按TEACH键确认并返回上级菜单。

注：默认为“Nor” 常规模式。

14) 485数据发送模式设定

菜单显示“t.Nod”，按TEACH进入子菜单。

子菜单项：“PoLL” 轮询模式（默认）；“SEr” 连续发送模式。

在子菜单下，按UP/DOWN进行选择，按TEACH键确认并返回上级菜单。

注：默认为“PoLL” 轮询模式，对传感器进行指令控制，该模式下能对指令进行响应；如需上电即对外发送距离数据，需将其切换到SEr” 连续发送模式。

15) 复位设定

菜单显示“rSEt”，按TEACH进入子菜单。

子菜单项：“no” 不执行复位；“yES” 执行复位，恢复默认设置。

5. 按键锁定功能

开启按键锁定：测量界面下，同时按下TEACH和UP键3秒以上，界面显示“Lc.on”，此时菜单功能失效；

关闭按键锁定：按键锁定开启后，同时按下TEACH和UP键3秒以上，界面显示“Lc.FA”，再次同时按下TEACH和UP键3秒以上，界面显示“Lc.oF”，按键功能恢复。

DIGITAL TUBE DISPLAY INTERPRETATION

SEN5	sens	teaching output
_m	_m	usually detected
_m_1	_m_1	1-point teaching
_m_2	_m_2	2-point teaching
_m_3	_m_3	3-point teaching
_mid	_mid	midpoint teaching
SPED	sped	set response speed
H-R50	h.rso	high precision 15ms
52d	std	standard 5ms
FAST	fast	high speed 1.5ms
L-d	l-d	set switch output direction
L-on	l-on	luminous
d-on	d-on	dark pass
HYS2	hyst	anti-shake settings
dELY	dely	switch output keep settings
0	0	no delay
P-n	p-n	set switch output
nPN	nPN	NPN
pnp	pnp	PNP
PULL	pull	push-pull output mode
disp	disp	set display mode
norm	norm	normal displacement mode
rev	rev	reverse displacement mode
dist	dist	distance mode
eco	eco	environmental protection settings
off	off	environmental protection close
on	on	environmental protection open
inpt	inpt	external input setting
L-off	l-of	stop light (turn off the laser)
L-on	l-on	start light (turn on the laser)
ADR	adr	485 communication address setting
baud	baud	485 communication baud rate setting
tnod	tnod	485 data transmission mode setting
ser	ser	continuous sending mode, always sending distance information
POLL	poll	polling mode, information will only be returned when a command is sent to it
rest	rest	reset settings
no	no	do not perform reset
YES	yes	perform reset
PAR	par	Check bit setting
none	none	No parity
evme	evme	even parity check
odd	odd	Odd check
tty	tty	485 protocol settings
bus	bus	modbus protocol
nor	nor	Regular protocol

INSTALLATION DIAGRAM

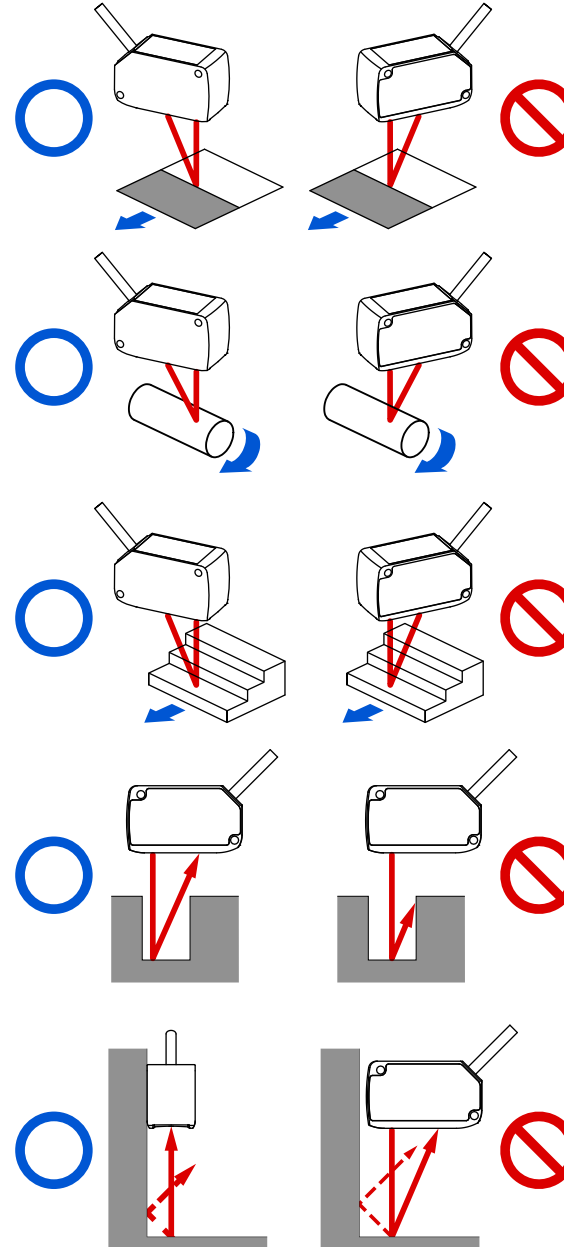

1. In the case of color or material difference
 When the material or color of moving object is extremely different, install it in the direction shown on the left to keep the measurement error to a minimum.

2. Detect rotating objects
 When detecting a rotating object, install it in the direction shown on the left, which can suppress the influence of the object's vertical vibration and position shift.

3. When there is a step
 If there is a step in the moving detection object, install it according to the method shown on the left, so as to suppress the influence of the step edge during measurement.

4. Measure in narrow places and recessed parts
 In the case of measuring in a narrow place or hole, please be careful not to block the light path from the light emitting part to the light receiving part when installing.

5. When installed on the wall
 Please install according to the method shown on the left to avoid the multiple reflected light from the wall entering the light receiving part.

数码管显示释义

SEN5	sens	教导输出
f	_m_	通常检测
_n_1	_m_1	1点教导
_n_2	_m_2	2点教导
_n_3	_m_3	3点教导
_n_d	_mid	中点教导
SPED	sped	设定响应速度
Hr50	h.rso	高精度速度15ms
std	std	标准速度5ms
FAST	fast	高速1.5ms
L-d	l-d	设定开关量输出方向
L-on	l-on	亮通
d-on	d-on	暗通
Hyst	hyst	防抖设定
dely	dely	开关量输出保持设定
0	0	无延迟
P-n	p-n	设定开关量输出类型
nPN	nPN	NPN输出模式
pnp	pnp	PNP输出模式
PULL	pull	推挽输出模式
disp	disp	设定显示模式
norm	norm	正常位移模式
rev	rev	反转位移模式
dist	dist	距离模式
eco	eco	环保设定
off	off	环保关
on	on	环保开
inpt	inpt	外部输入设定
L-of	l-of	停止投光 (关闭激光)
L-on	l-on	开启投光 (开启激光)
adr	adr	485通讯地址设定
baud	baud	485通讯波特率设定
tnod	tnod	485数据发送模式设定
ser	ser	连续发送模式, 一直对外发送距离信息
poll	poll	轮询模式, 对其发送指令时, 才返回相应信息
rest	rest	复位设定
no	no	不执行复位
yes	yes	执行复位
par	par	校验位设定
mome	mome	无校验
evme	evme	偶校验
odd	odd	奇校验
tty	tty	485协议设定
bus	bus	ModBus协议
nor	nor	常规协议

安装示意图

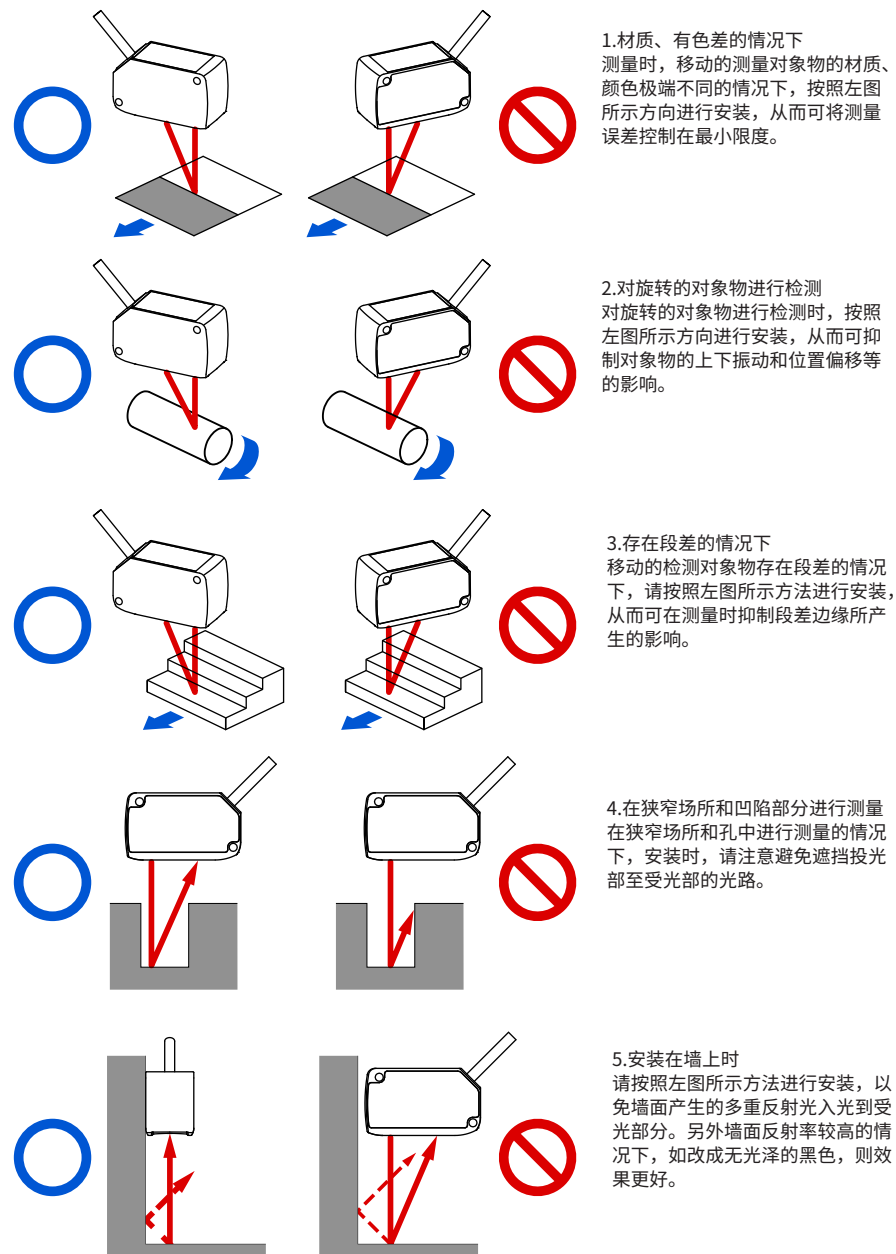

OSM41-RS485 COMMUNICATION PROTOCOL

1. Conventional protocol

Default: baud rate: 115200bps, 8 data bits, 1 start bit, 1 stop bit, no parity.

1.1 Full frame data format description

start character (1byte)	address bit (1byte)	byte length (1byte)	command code (1byte)	data bit(nbyte)	sum check(2byte) cs1 cs2	terminator (1byte)
0x68	adr	from the command code to the checked byte	see command list	see command details (little endian format)	sum check from data to address (little endian format)	0x16

Supplementary description of data format:

- 1) start character: 0x68, which is the start byte of a frame of data;
- 2) The address bit adr can be set through the menu or command, and the settable range is 0~254(0xfe); The default address is 0, and the broadcast address is 0xff;
- 3) Byte length refers to the number of bytes from the command code to the check code (including check code);
- 4) Command code: different command codes correspond to different function commands, see the table below for details;
- 5) Data bit: the returned data can be 1 byte or multiple bytes, and the data format is little endian. little endian format: low byte first, high byte after; for example: for data 0x1234, first pass the low byte 0x34, and then pass the high byte 0x12;
- 6) The check is a sum check, the sum from the address bit to the data bit, the data format is little endian format. For example, the distance reading command: 68 ff 03 00 02 01 16, ff is address code, 03 is byte length, including 1 command code and 2 check bytes. 0xff+0x03+0x00=0x0102, the low byte is in the front and the high byte is in the back, cs1=0x02, cs2=0x01, 00 is the instruction code.
- 7) Terminator: 0x16, which is the end mark of a frame of data;
- 8) Sending data and returning commands meet the above command frame format; Example of sending instruction: distance reading instruction: 68 ff 03 00 02 01 16 Analysis: 68 is the start character, ff is the broadcast address; 03 is the byte length, including 1 instruction code and 2 check bytes; 00 is the command code; 02 01 is the check byte; 16 is the end code.

1.2 Example of receiving instruction:

distance return instruction: 68 01 05 00 FC FF 01 02 16

Analysis: 68 is the start character, 01 is the address code; 05 is the byte length, including 1 instruction code, 2 data bytes, and 2 check bytes; FC FF is the data bytes, Little endian format is converted to hexadecimal as 0xFFFFC.

- 1) When the current display mode is distance mode, the corresponding decimal is 65532. When the distance unit is 0.01mm, actual distance is 655.32mm; When the distance unit is 0.1mm, actual distance is 6553.2mm.
- 2) When the current display mode is displacement mode or displacement inversion mode, the corresponding decimal is -4. When the distance unit is 0.01mm, actual distance is -0.04mm; When the distance unit is 0.1mm, actual distance is -0.4mm. 01 02 is the sum check byte, the little endian format is converted to hexadecimal as 0x0201, 16 is the end code.

1.3 Read command list

Function description	Command code	Full instruction	return instruction	Remark
Reading distance	0x00	68 adr 03 00 cs1 cs2 16 take address 0xff as an example: 68 ff 03 00 02 01 16	68 adr 05 00 d1 d2 cs1 cs2 16	d1 d2: distance data; little endian format, there is no symbol when the display mode is distance mode, there are symbol when the displaying modes; unit is the same as distance
Reading distance unit	0x01	68 adr 03 01 cs1 cs2 16 example: 68 ff 03 01 03 01 16	68 adr 04 01 d1 cs1 cs2 16	d1: distance unit: 0: 1mm 1: 0.1mm 2: 0.01mm 3: 0.001mm

Function description	Command code	Full instruction	return instruction	Remark
Read taeaching mode	0x02	68 adr 03 02 cs1 cs2 16 example: 68 ff 03 02 04 01 16	68 adr 04 02 d1 cs1 cs2 16	d1: taeaching mode: 0x00: normal taeaching mode 0x01: 1-point taeaching mode 0x02: 2-point taeaching mode 0x03: 3-point taeaching mode 0x04: midpoint taeaching mode
Read taeaching data	0x03	68 adr 03 m1 cs1 cs2 16 read the position of the first teaching point 68 ff 04 03 00 06 01 16 read the position of the second teaching point 68 ff 04 03 01 07 01 16 read the position of the third teaching point 68 ff 04 03 02 08 01 16 read the positive and negative interval of 1-point teaching: 68 ff 04 03 80 86 01 16	68 adr 05 03 d1 d2 cs1 cs2 16	Teaching data index m1: 0: position of first teaching point 1: position of second teaching point 2: position of the third teaching point 0x80: the positive and negative interval of 1-point teaching d1 d2: the distance has been set; the teaching point of normal taeaching mode and midpoint taeaching mode is the first teaching point.
Read response speed	0x04	68 adr 03 04 cs1 cs2 16 example: 68 FF 03 04 06 01 16	68 adr 04 04 d1 cs1 cs2 16	Teaching data index m1: 0d1: response speed: 0x00: accurate (10ms) 0x01: standard (5ms) 0x02: fast (1.5ms)
Read light/dark on status	0x05	68 adr 03 05 cs1 cs2 16 example: 68 ff 03 05 07 01 16	68 adr 04 05 d1 cs1 cs2 16	d1: light/dark on status 0x00: light on 0x01: dark on
Read output hysteresis	0x06	68 adr 03 06 cs1 cs2 16 example: 68 ff 03 06 08 01 16	68 adr 05 06 d1 d2 cs1 cs2 16	d1 d2: hysteresis data; unit is the same as distance;
Read output hold time	0x07	68 adr 03 07 cs1 cs2 16 example: 68ff 03 07 09 01 16	68 adr 05 07 d1 d2 cs1 cs2 16	d1 d2: output hold time unit: ms
Read digital output type	0x08	68adr 03 08 cs1 cs2 16 example: 68 ff 03 08 0a 01 16	68 adr 04 08 d1 cs1 cs2 16	d1: digital output type: 0x00: NPN 0x01: PNP 0x02: push-pull
Read display mode	0x09	68 adr 03 09 cs1 cs2 16 example: 68 ff 03 09 0b 01 16	68 adr 04 09 d1 cs1 cs2 16	d1: display mode: 0x00: displacement mode 0x01: displacement inversion mode 0x02: distance mode
Read ECO mode	0x0A	68 adr 03 0a cs1 cs2 16 example: 68 ff 03 0a 0c 01 16	68 adr 04 0a d1 cs1 cs2 16	d1: ECO mode: 0x00: disable 0x01: enable
Read the laser tube switch status	0x0B	68 adr 03 0b cs1 cs2 16 example: 68 ff 03 0b 0d 01 16	68 adr 04 0b d1 cs1 cs2 16	d1: laser tube switch status 0x00: close 0x01: open
Read keyboard lock status	0x0C	68 adr 03 0c cs1 cs2 16 example: 68 ff 03 0c 0e 01 16	68 adr 04 0c d1 cs1 cs2 16	d1: keyboard lock status: 0x00: customer operation enable 0x01: key operation prohibited 0x02: factory operation enable

OSM41-RS485通讯协议

1.常规协议

默认：波特率：115200bps，8位数据位，1位起始位，1位停止位，无奇偶校验。

1.1完整帧数据格式说明

起始符 (1byte)	地址位 (1byte)	字节长度 (1byte)	命令码(1byte)	数据位(nbyte)	和校验(2byte) cs1 cs2	结束符 (1byte)
0x68	adr	从命令码到 校验的字节数	见命令列表	见命令详解 (小端格式)	从地址到数据的 和校验(小端格式)	0x16

数据格式补充说明：

- 1) 起始符：0x68，为一帧数据的起始字节；
- 2) 地址位adr可通过菜单或者指令设定，可设定范围为0~254 (0xfe)；默认地址为0，广播地址为0xff；
- 3) 字节长度指的是从命令码到校验码的字节数(含校验码)；
- 4) 命令码：不同命令码对应不同功能指令，详见下表；
- 5) 数据位：返回数据可为1个字节，也可为多个字节，数据格式为小端格式
小端格式：低字节在前，高字节在后；
例如数据0x1234，传递时先传递低字节0x34，再传递高字节0x12；
- 6) 校验为和校验，从地址位到数据位的和，数据格式位小端格式
例如，距离读取指令：68 ff 03 00 02 01 16，ff为地址码，03为字节长度，包含1个指令码与2个校验字节，0xff+0x03+0x00=0x0102，传递时低字节在前，高字节在后，cs1=0x02，cs2=0x01，00为指令码。
- 7) 结束符：0x16，为一帧数据的结束标志；
- 8) 发送数据和返回指令均满足以上指令帧格式；
发送指令示例：距离读取指令：68 ff 03 00 02 01 16
解析：68为起始符，ff为广播地址码；03为字节长度，包含1个指令码与2个校验字节；00为命令码；02 01 为校验字节；16为结束码

1.2接收指令示例：

距离返回指令：68 01 05 00 FC FF 01 02 16

解析：68为起始符；01为地址码；05为字节长度，包含1个指令码，2个数据字节，2个校验字节；FC FF为数据字节，小端格式转化为十六进制为0xFFFFC。

1) 当前显示模式为距离模式时，对应的十进制为65532，距离单位为0.01mm时，对应的实际距离为655.32mm；距离单位为0.1mm时，对应的实际距离为6553.2mm。

2) 当前显示模式为位移模式或位移取反模式时，对应的十进制为-4，距离单位为0.01mm时，对应的实际距离为-0.04mm；距离单位为0.1mm时，对应的实际距离为-0.4mm。

01 02 为和校验字节，小端格式转化为十六进制为0x0201；16为结束码；

1.3读取命令列表

功能描述	命令码	全指令	返回指令	备注
读取距离	0x00	68 adr 03 00 cs1 cs2 16 以地址0xff为例： 68 ff 03 00 02 01 16	68 adr 05 00 d1 d2 cs1 cs2 16	d1 d2:距离数据;小端格式,显示模式为距离模式时为无符号,其他显示模式为有符号;单位同距离单位;
读取距离单位	0x01	68 adr 03 01 cs1 cs2 16 例： 68 ff 03 01 03 01 16	68 adr 04 01 d1 cs1 cs2 16	d1:为距离单位: 0:1mm 1:0.1mm 2:0.01mm 3:0.001mm

功能描述	命令码	全指令	返回指令	备注
读取教导模式	0x02	68 adr 03 02 cs1 cs2 16 例： 68 ff 03 02 04 01 16	68 adr 04 02 d1 cs1 cs2 16	d1:教导模式: 0x00:通常教导模式 0x01:1点教导模式 0x02:2点教导模式 0x03:3点教导模式 0x04:中点教导模式
读取教导数据	0x03	68 adr 03 m1 cs1 cs2 16 读取第1个教导点位置: 68 ff 04 03 00 06 01 16 读取第2个教导点位置: 68 ff 04 03 01 07 01 16 读取第3个教导点位置: 68 ff 04 03 02 08 01 16 读取1点教导的正负区间: 68 ff 04 03 80 86 01 16	68 adr 05 03 d1 d2 cs1 cs2 16	教导数据索引m1: 0:第1个教导点位置 1:第2个教导点位置 2:第3个教导点位置 0x80:1点教导的正负区间 d1 d2:已设定距离; 通常教导模式和中点教导模式的教导点为第1个教导点。
读取响应速度	0x04	68 adr 03 04 cs1 cs2 16 例： 68 FF 03 04 06 01 16	68 adr 04 04 d1 cs1 cs2 16	教导数据索引m1: 0d1:响应速度: 0x00:精确(10ms) 0x01:标准(5ms) 0x02:快速(1.5ms)
读取亮/暗通状态	0x05	68 adr 03 05 cs1 cs2 16 例： 68 ff 03 05 07 01 16	68 adr 04 05 d1 cs1 cs2 16	d1:亮/暗通状态: 0x00:亮通 0x01:暗通
读取输出回差	0x06	68 adr 03 06 cs1 cs2 16 例： 68 ff 03 06 08 01 16	68 adr 05 06 d1 d2 cs1 cs2 16	d1 d2:为回差数据; 单位同距离单位;
读取输出保持时间	0x07	68 adr 03 07 cs1 cs2 16 例： 68 ff 03 07 09 01 16	68 adr 05 07 d1 d2 cs1 cs2 16	d1 d2:输出保持时间 单位 ms
读取数字输出类型	0x08	68 adr 03 08 cs1 cs2 16 例： 68 ff 03 08 0a 01 16	68 adr 04 08 d1 cs1 cs2 16	d1:数字输出类型: 0x00:NPN 0x01:PNP 0x02:推挽
读取显示模式	0x09	68 adr 03 09 cs1 cs2 16 例： 68 ff 03 09 0b 01 16	68 adr 04 09 d1 cs1 cs2 16	d1:显示模式: 0x00:位移模式 0x01:位移取反模式 0x02:距离模式
读取ECO模式	0x0A	68 adr 03 0a cs1 cs2 16 例： 68 ff 03 0a 0c 01 16	68 adr 04 0a d1 cs1 cs2 16	d1: ECO模式: 0x00:不使能 0x01:使能
读取激光管开关状态	0x0B	68 adr 03 0b cs1 cs2 16 例： 68 ff 03 0b 0d 01 16	68 adr 04 0b d1 cs1 cs2 16	d1:激光管开关状态 0x00:关 0x01:开
读取键盘锁状态	0x0C	68 adr 03 0c cs1 cs2 16 例： 68 ff 03 0c 0e 01 16	68 adr 04 0c d1 cs1 cs2 16	d1:键盘锁状态: 0x00:客户操作使能 0x01:按键操作禁止 0x02:厂家操作使能

Function description	Command code	Full instruction	return instruction	Remark
Read switch output status	0x0D	68 adr 03 0c cs1 cs2 16 examl: 68 ff 03 0d 0f 01 16	68 adr 04 0d d1 cs1 cs2 16	d1: digital output type: 0x00: disconnect 0x01: conduction
Read version number	0x0E	68 adr 03 0c cs1 cs2 16 examl: 68 ff 03 0e 10 01 16	68 adr 05 0e d1 d2 cs1 cs2 16	d1: hardware version number d2: software version number

1.4 Set command list

set address	0x80	68 adr 04 80 d1 cs1 cs2 16 examl:set address as 1: 68 ff 04 80 01 84 01 16	68 adr 04 80 state cs1 cs2 16 return: state 0: success; 1: fail	d1: set address set range1-254, 0xFF is broadcast address, 0x00 reserve
set baud rate	0x81	68 adr 04 81 d1 cs1 cs2 16 examl: set baud rate as115200 68 ff 04 81 05 89 01 16	68 adr 04 81 state cs1 cs2 16 return: state 0: success; 1: fail	d1: corresponding baud rate level 0x00: 2400bit/s 0x01: 4800bit/s 0x02: 9600bit/s 0x03: 19200bit/s 0x04: 38400bit/s 0x05: 115200bit/s
set teaching mode (1 byte) +teaching data (n byte)	0x82	68 ff n1 82 c1 cs1 cs2 16 examl:set as normal teaching mode teaching distance is 400.0mm: 68 ff 06 82 00 a0 f 36 02 16	68 adr 04 82 state cs1 cs2 16 return: state 0: success; 1: fail	n1: number of bytes different teaching mode includes different bytes: normal taeaching mode: ncluding one teaching point location (2byte) ; 1-point taeaching mode: including one teaching point (2byte)+interval(2byte); 2-point taeaching mode: two teaching point location(4byte) 3-point taeaching mode: three teaching point location(6byte) midpoint taeaching mode: two teaching point location(4byte) c1: taeaching mode 0x00: normal taeaching mode 0x01: 1-point taeaching mode 0x02: 2-point taeaching mode 0x03: 3-point taeaching mode 0x04: midpoint taeaching mode teaching distance
Set continuous sending mode	0x83	68 adr 04 83 00 cs1 cs2 16 examl: set continuous sending mode command: 68 ff 04 83 00 86 01 16	68 adr 04 82 state cs1 cs2 16 return: state 0: success; 1: fail	In this mode,it can only be sent to but not received.Exiting this mode can only be set through the menu. In this mode ,only one device can be mounted on the bus.
Set output response speed	0x84	68 adr 04 84 d1 cs1 cs2 16 examl: set to fast response speed: 68 ff 04 84 02 89 01 16	68 adr 04 84 state cs1 cs2 16 return: state 0: success; 1: fail	d1: corresponding response speed level 0x00: accurate (10ms) 0x01: standard (5ms) 0x02: fast (1.5ms)

Function description	Command code	Full instruction	return instruction	Remark
Set digital output direction	0x85	68 adr 04 85 d1 cs1 cs2 16 examl: set as dark on 68 ff 04 85 01 89 01 16	68dr 04 85 state cs1 cs2 16 return: state 0: success; 1: fail	d1: digital output direction: 0x00: light on 0x01: dark on
Set hysteresis	0x86	68 adr 05 86 d1 d2 cs1 cs2 16 examl:set hysteresis as 1mm: 68 ff 05 86 10 00 9a 01 16	68 adr 04 86 state cs1 cs2 16	d1 d2: hysteresis distance unit is the same as distance return: state 0: success; 1: fail
Set digital output hold time	0x87	68 adr 05 87 d1 d2 cs1 cs2 16 examl:set hold time as 20ms: 68 ff 05 87 14 00 9f 01 16	68 adr 04 87 state cs1 cs2 16	d1 d2: output hold time unit:ms return: state 0: success; 1: fail
Set digital output type	0x88	68 adr 04 88 d1 cs1 cs2 16 examl: set output type as NPN 68 ff 04 88 01 8c 01 16	68 adr 04 88 state cs1 cs2 16	d1: output type 0x00: NPN 0x01: PNP 0x02: push-pull return: state 0: success; 1: fail
Set display mode	0x89	68 adr 04 89 d1 cs1 cs2 16 examl: set display mode as distance mode 68 ff 04 89 02 8e 01 16	68 adr 04 89 state cs1 cs2 16	d1: display mode 0x00: displacement mode 0x01: displacement inversion mode 0x02: distance mode return: state 0: success; 1: fail
Set ECO mode	0x8A	68 adr 04 8a d1 cs1 cs2 16 examl: set enable ECO mode 68 ff 04 8a 01 8e 01 16	68 adr 04 8a state cs1 cs2 16	d1: ECO mode 0x00: disable 0x01: enable return: state 0: success; 1: fail
Set the laser tube switch status	0x8B	68 adr 04 8b d1 cs1 cs2 16 examl:set the laser tube switch status as open 68 ff 04 8B 00 8e 01 16	68 adr 04 8b state cs1 cs2 16	d1: laser tube switch status 0x00: close 0x01: open return: state 0: success; 1: fail
Set zero point	0x94	68 adr 04 94 d1 cs1 cs2 16 Set the current detection distance to zero , for example, 68 ff 04 94 01 98 01 16 Cancel zeroing , for example, 68 ff 04 94 00 97 01 16	68 adr 04 94 state cs1 cs2 16	d1: Return to zero state 0x00: Restore zero point 0x01: Set zero point Return: state 0: Success; 1: Fail, the current display mode is distance mode or the detected distance is out of range

功能描述	命令码	全指令	返回指令	备注
读取开关输出状态	0x0D	68 adr 03 0c cs1 cs2 16 例: 68 ff 03 0d 0f 01 16	68 adr 04 0d d1 cs1 cs2 16	d1:数字输出类型: 0x00:断开 0x01:导通
读取版本号	0x0E	68 adr 03 0c cs1 cs2 16 例: 68 ff 03 0e 10 01 16	68 adr 05 0e d1 d2 cs1 cs2 16	d1:硬件版本号 d2:软件版本号

1.4设置命令列表

功能描述	命令码	全指令	返回指令	备注
设置地址	0x80	68 adr 04 80 d1 cs1 cs2 16 例,设置地址为1: 68 ff 04 80 01 84 01 16	68 adr 04 80 state cs1 cs2 16 返回:state 0:成功;1:失败	d1:设备地址 设置范围1-254, 0xFF为广播地址, 0x00保留
设置波特率	0x81	68 adr 04 81 d1 cs1 cs2 16 例, 设置波特率为115200 68 ff 04 81 05 89 01 16	68 adr 04 81 state cs1 cs2 16 返回:state 0:成功;1:失败	d1:对应波特率等级 0x00:2400bit/s 0x01:4800bit/s 0x02:9600bit/s 0x03:19200bit/s 0x04:38400bit/s 0x05:115200bit/s
设置教导模式 (1 byte) +教导数据 (n byte)	0x82	68 ff n1 82 c1 cs1 cs2 16 例:设置为通常教导模式, 教导距离为400.0mm: 68 ff 06 82 00 a0 0f 36 02 16	68 adr 04 82 state cs1 cs2 16 返回:state 0:成功;1:失败	n1:字节数 不同教导模式包含字节数不同: 通常教导模式:包含一个教导点 位置(2byte); 1点教导模式:包含一个教导点 (2byte)+区间(2byte); 2点教导模式:2个教导点位置 (4byte) 3点教导模式:3个教导点位置 (6byte) 中点教导模式:2个教导点位置 (4byte) c1:教导模式 0x00:通常教导模式 0x01:1点教导模式 0x02:2点教导模式 0x03:3点教导模式 0x04:中点教导模式 教导距离
设置连续发送模式	0x83	68 adr 04 83 00 cs1 cs2 16 例, 设置连续发送模式指令: 68 ff 04 83 00 86 01 16	68 adr 04 83 state cs1 cs2 16 返回:state 0:成功;1:失败	该模式下,只能发送给不能接收, 退出此模式只能通过菜单设定; 该模式下,总线上只能挂载一台 设备;
设置输出响应速度	0x84	68 adr 04 84 d1 cs1 cs2 16 例, 设置为快速响应模式 68 ff 04 84 02 89 01 16	68 adr 04 84 state cs1 cs2 16 返回:state 0:成功;1:失败	d1:对应响应速度等级 0x00:精确(10ms) 0x01:标准(5ms) 0x02:快速(1.5ms)

功能描述	命令码	全指令	返回指令	备注
设置数字输出方向	0x85	68 adr 04 85 d1 cs1 cs2 16 例, 设置为暗通模式 68 ff 04 85 01 89 01 16	68 adr 04 85 state cs1 cs2 16 返回:state 0:成功;1:失败	d1:数字输出方向: 0x00:亮通 0x01:暗通
设置回差	0x86	68 adr 05 86 d1 d2 cs1 cs2 16 例,设定回差为1mm: 68 ff 05 86 10 00 9a 01 16	68 adr 04 86 state cs1 cs2 16	d1 d2:回差距离 单位同距离单位 返回:state 0:成功;1:失败
设置数字输出保持时间	0x87	68 adr 05 87 d1 d2 cs1 cs2 16 例,设定保持时间为20ms: 68 ff 05 87 14 00 9f 01 16	68 adr 04 87 state cs1 cs2 16	d1 d2:输出保持时间 单位ms 返回:state 0:成功;1:失败
设置数字输出类型	0x88	68 adr 04 88 d1 cs1 cs2 16 例, 设定输出类型为NPN 68 ff 04 88 01 8c 01 16	68 adr 04 88 state cs1 cs2 16	d1:输出类型 0x00:NPN 0x01:PNP 0x02:推挽 返回:state 0:成功;1:失败
设置显示模式	0x89	68 adr 04 89 d1 cs1 cs2 16 例, 设定显示模式为距离模式 68 ff 04 89 02 8e 01 16	68 adr 04 89 state cs1 cs2 16	d1:显示模式 0x00:位移模式 0x01:位移取反模式 0x02:距离模式 返回:state 0:成功;1:失败
设置ECO模式	0x8A	68 adr 04 8a d1 cs1 cs2 16 例, 设定使能ECO模式 68 ff 04 8a 01 8e 01 16	68 adr 04 8a state cs1 cs2 16	d1:ECO模式 0x00:不使能 0x01:使能 返回:state 0:成功;1:失败
设置激光管开关状态	0x8B	68 adr 04 8b d1 cs1 cs2 16 例,设定激光管状态为开 68 ff 04 8b 00 8e 01 16	68 adr 04 8b state cs1 cs2 16	d1:激光管开关状态 0x00:关 0x01:开 返回:state 0:成功;1:失败
设置零点	0x94	68 adr 04 94 d1 cs1 cs2 16 将当前检测距离设置为零点, 例68 ff 04 94 01 98 01 16 取消归零,例 68 ff 04 94 00 97 01 16	68 adr 04 94 state cs1 cs2 16	d1:归零状态 0x00:恢复零点 0x01:设置零点 返回:state 0:成功;1:失败,当前显示模式 为距离模式或检测距离在量程外

2.Modbus communication description

2.1 Basic information

Baud rate: 9600bps, 8 data bits, 1 start bit, 1 stop bit, no parity
 Default output mode: passive (Poll)
 Default address: 0x01

2.2 Modbus communication interactive instruction format

2.2.1 Take the default address 0x01 as an example to illustrate the instruction format.

1) The instruction format for reading registers is as follows:

address	function code	register address	Number of registers	CRC_L	CRC_H
01	03	00 00	00	01	xx xx

2) Device response packet format for reading registers:

address	function code	Date byte length	High distance value	Low distance value	CRC_L	CRC_H
01	03	02	xx	xx	xx	xx

3) Device response format of reading registers instruction error or device internal error:

address	function code	Date byte length	Error code high bit	Error code low bit	CRC_L	CRC_H
01	83	02	00	xx	xx	xx

4) The instruction format for writing the registers value is as follows:

address	function code	register address	high date bit	low date bit	CRC_L	CRC_H
01	06	xx xx	xx	xx	xx	xx

5) Write the correct response format to the device side for register operation:

The response packet is the same as the issued packet.

6) The response format for handling exceptions on the device side of writing register operations:

address	function code	Date byte length	Error code high bit	Error code low bit	CRC_L	CRC_H
01	86	02	00	xx	xx	xx

2、 Field Description:

1) Address: Device address, default to 0x01

2) Function code:

03- Read Register;06- Write Register;83- Register read exception response;86- Register write exception response

3) Register address:

All registers are 16 bit registers, and after modifying all registers, a "save configuration" instruction must be sent and the device must be powered on again to take effect. The register description is shown in Table 1 below.

Table 1 register

Register address	Defines	Description	Permission	Value range
00 00	the distance value	The output result of the sensor, which is the distance value for this sensor, Unit: resolution	Read only	Same sensor range
00 06	major version number	00+ major version number	Read only	Actual version number
00 07	Minor version number	Minor version number+revision number	Read only	Actual version number
00 80	Save configuration	Can write any number, the device only focus on instruction function code	Write only	0~65535
00 83	Baud rate High	Configure baud rate. The reboot takes effect after the save configuration instruction is sent. For now 2400、 4800、 9600、 19200、 38400、 115200	Read and write	0 or 1
00 84	Baud rate Low		Read and write	2400、 4800、 9600、 19200、 38400、 49664
00 85	Device ID	Configure device address, default 0x01, save and restart valid	Read and writew	1~247
00 86	Parity check	Check bit settings	Read and write	0-No parity ;1-odd parity 2-even parity check
00 87		Configure the working mode of the device	Read and write	0-continuous sending mode 1-polling mode (default)

00 89	Restore factory settings	Any numeric value can be written, reboot is valid	Read and write	0~65535
00 A0	Sets the display mode	Sets the display mode	Read and write	0x00: Displacement mode 0x01: Displacement inversion mode 0x02: Distance mode
00 A1	Set zero point	Set zero point	Write only	0x00: Restore zero point 0x01: Set zero point
00 A2	Reading zero displacement	Reading zero displacement	Read only	Same sensor range

4) Register count:

The number of registers pre-read from a register instruction. Values range from 1 to 8.

5) Data byte length:

Read register instruction reply, the number of bytes in the reply data segment.

6) Error code:

When reading and writing registers, issuing instruction format is wrong, or the data segment in the device response package is error code. The meaning of the error code is shown in Table 2 below

Table 2 error code description

Error code	Description
0x0001	Register address error
0x0002	Register write error

7) CRC Check:

In the protocol, a message carries a two-byte CRC check code, which is CRC16 check, the penultimate second byte of the message is the low byte of the check code, and the penultimate first byte of the message is the high byte of the check code.

Parametric model: X16 + X15 + x2 + 1;Polynomial: 0x8005;Initial value: 0xFFFF

3、 An example of interactive information

Function	Instructions	Successful return value	Description
Gets the distance value	01 03 00 00 00 01 84 0A	01 03 02 DH DL CL CH	DH and DL are the high 8 bit and low 8 bit of the measured values, while CH and CL are the low 8 bit and high 8 bit of CRC, respectively
Gets the version number	01 03 00 06 00 02 24 0A	01 03 04 00 VM VS VC CL CH	VM, VS, and VC are the major, minor, and minor version numbers of the version
Set the baud rate	01 06 00 83 BH1 BH2 CL CH 01 06 00 84 BL1 BL2 CL CH	01 06 00 83 BH1 BH2 CL CH 01 06 00 84 BL1 BL2 CL CH	Bh1, BH2, BL1, BL2 are the highest, the second highest, the second lowest, and the lowest bits of baud rate, respectively. For example, the modified baud rate is 9600 , BH1=00 BH2=00 CL=78 CH=22,BL1=25 BL2=80 CL=D2 CH=D3
Modify the device ID	01 06 00 85 IH IL CL CH	01 06 00 85 IH IL CL CH	IH, I L for ID high and low bytes, 1-247,0x00 for broadcast address. Modify ID to 2, IH = 00 IL = 02 cl = 19 ch = E2
Change the parity bit	01 06 00 86 00 01 CL CH	01 06 00 86 00 01 CL CH	Set to odd check
Modify the device mode	01 06 00 87 00 M CL CH	01 06 00 87 00 M CL CH	M is device mode instruction byte M = 00 is continuous send mode M = 01 is query mode (default)
Save the configuration	01 06 00 80 00 00 88 22	01 06 00 80 00 00 88 22	Reboot takes effect after saving
Restore factory settings	01 06 00 89 00 00 58 20	01 06 00 89 00 00 58 20	The device ID address and baud rate are reset to factory status
Sets the display mode	01 06 00 A0 00 00 89 E8 01 06 00 A0 00 01 48 28 01 06 00 A0 00 02 08 29	Set successfully:simultaneous sending instruction Setup failed:error code 4	0x00: Displacement mode 0x01: Displacement inversion mode 0x02: Distance mode
Set zero point	01 06 00 A1 00 00 D8 28 01 06 00 A1 00 01 19 E8		0x00: Restore zero point 0x01: Set zero point
Reading zero displacement	01 03 00 A2 00 01 25 E8		Read only

2. Modbus通信说明

2.1 基本信息 (默认)

波特率: 9600bps, 8位数据位, 1位起始位, 1位停止位, 无奇偶校验。

默认输出方式: 被动(Poll); 默认地址: 0x01;

2.2 Modbus通信交互指令格式

2.2.1 以默认地址0x01为例说明指令格式

1) 读取寄存器的指令格式如下:

地址	功能码	寄存器地址		寄存器数量		CRC_L	CRC_H
01	03	00	00	00	01	xx	xx

2) 读取寄存器的设备应答包格式:

地址	功能码	数据字节长度	距离值高位	距离值低位	CRC_L	CRC_H
01	03	02	xx	xx	xx	xx

3) 读取寄存器指令错误或内部设备出错的设备应答格式:

地址	功能码	数据字节长度	错误码高位	错误码低位	CRC_L	CRC_H
01	83	02	00	xx	xx	xx

4) 写入寄存器数值的指令格式如下:

地址	功能码	寄存器地址		数据高位	数据低位	CRC_L	CRC_H
01	06	xx	xx	xx	xx	xx	xx

5) 写入寄存器操作设备端处理正确的应答格式: 应答数据包与下发数据包相同。

6) 写入寄存器操作设备端处理异常的应答格式:

地址	功能码	数据字节长度	错误码高位	错误码低位	CRC_L	CRC_H
01	86	02	00	xx	xx	xx

2.2.2 字段说明:

1) 地址: 设备地址, 默认0x01

2) 功能码: 03——读寄存器; 06——写寄存器; 83——读寄存器异常应答; 86——写寄存器异常应答;

3) 寄存器地址:

所有寄存器都为16bit寄存器, 所有寄存器修改后必须发送“保存配置”指令且重新上电设备才生效。

寄存器说明见下表1。

表1 寄存器说明

寄存器地址	定义	说明	权限	取值范围
00 00	距离值	传感器的输出结果, 对于此传感器为距离值, 单位: 分辨率	只读	同传感器量程
00 06	主版本号	00+主版本号	只读	实际版本号
00 07	次版本号	次版本号+修正版本号	只读	实际版本号
00 80	保存配置	可以写入任意数值, 设备只关注指令功能码	只读	0~65535
00 83	波特率High	配置波特率。发送保存配置指令后重启生效。暂仅支持2400、4800、9600、19200、38400、115200	读写	0或1
00 84	波特率Low		读写	2400/4800、9600、19200、38400、49664
00 85	设备ID	配置设备地址, 默认0x01, 保存后重启有效	读写	1~247
00 86	奇偶校验	校验位设置	读写	0-无校验; 1-奇校验; 2-偶校验
00 87	工作模式	配置设备的工作模式	读写	0-为连续发送模式 1-为查询模式(默认)
00 89	恢复出厂设置	可以写入任意数值, 重启有效	读写	0~65535
0x A0	设置显示模式	设置显示模式	读写	0x00: 位移模式; 0x01: 位移取反模式; 0x02: 距离模式
0x A1	设置零点	设置零点	读写	0x00: 恢复零点 0x01: 设置零点
0x A2	读取零点偏移	读取零点偏移	只读	同传感器量程

4) 寄存器数量:

读取寄存器指令中, 预读取的寄存器的数量。取值1~8。

5) 数据字节长度:

读取寄存器指令应答中, 表示应答数据段的字节个数。

6) 错误码:

读写寄存器时下发指令格式错误或设备内部处理异常时, 设备应答包中数据段为错误码。

错误码含义如下表2。

表2 错误码说明

错误码	说明
0x0001	寄存器地址错误
0x0002	寄存器写入值错误

7) CRC校验:

协议中一帧报文携带两个字节的CRC校验码, 为CRC16校验, 报文倒数第二字节为校验码低字节,

报文倒数第一字节为校验码高字节。

参数模型: $x^{16} + x^{15} + x^2 + 1$;

多项式: 0x8005;

初始值: 0xFFFF

2.3 交互信息示例

表1 寄存器说明

功能	指令	成功返回值	说明
获取距离值	01 03 00 00 00 01 84 0A	01 03 02 DH DL CL CH	DH、DL分别是传感器测量值低16位的高8bit和低8bit; CH、CL分别为CRC的低8bit和高8bit
获取软件版本号	01 03 00 06 00 02 24 0A	01 03 04 00 VM VS VC CL CH	VM、VS、VC 分别是版本的主、次、修正版本号
设置波特率	01 06 00 83 BH1 BH2 CL CH 01 06 00 84 BL1 BL2 CL CH	01 06 00 83 BH1 BH2 CL CH 01 06 00 84 BL1 BL2 CL CH	BH1、BH2、BL1、BL2分别为波特率的高、次高、次低、低字节。例如修改波特率为9600, BH1=00 BH2=00 CL=78 CH=22, BL1=25 BL2=80 CL=D2 CH=D3
修改设备ID	01 06 00 85 IH IL CL CH	01 06 00 85 IH IL CL CH	IH、IL为ID的高字节和低字节, 1-247, 0x00为广播地址, 修改ID为 2, IH=00 IL=02 CL=19 CH=E2
修改奇偶校验位	01 06 00 82 00 01 E8 22	01 06 00 86 00 01 CL CH	设置成奇校验
修改设备模式	01 06 00 87 00 M CL CH	01 06 00 87 00 M CL CH	M为设备模式的指令字节 M=00为连续发送模式 M=01为查询模式(默认)
保存配置	01 06 00 80 00 00 88 22	01 06 00 80 00 00 88 22	保存后重启生效
恢复出厂设置	01 06 00 89 00 00 58 20	01 06 00 89 00 00 58 20	保存后重启生效, 设备的ID地址和波特率重置为出厂状态
设置显示模式	01 06 00 A0 00 00 89 E8	设置成功: 同发送指令	0x00: 位移模式
	01 06 00 A0 00 01 48 28	设置失败: 错误码4	0x01: 位移取反模式
	01 06 00 A0 00 02 08 29		0x02: 距离模式
设置零点	01 06 00 A1 00 00 D8 28		0x00: 恢复零点
	01 06 00 A1 00 01 19 E8		0x01: 设置零点
读取零点偏移	01 03 00 A2 00 01 25 E8	01 03 00 08 00 M CL CH	只读