

## Product Description:

- OSC1 controllers are used in combination with OSMT60 sensor head, with teaching mode, multiple working modes and output modes.

## Product features:

- High-precision, sensor head and controllers are installed separately.
- Support multiple detection modes and multiple scene applications.
- OLED display, optional in Chinese and English.



Type	Output	Sensor head connection mode	Number of sensor head connections	Connection
OSC1-UC2B6-Q8/485	NPN/PNP+485	M8-4pin connector	MAX.2	2M cable

## TECHNICAL SPECIFICATION

<b>OPERATING VOLTAGE</b>	10...24VDC	<b>RESOLUTION</b>	1μm
<b>RIPPLE VOLTAGE</b>	±10% of U <sub>B</sub>	<b>OUTPUT MODES</b>	2*PNP/NPN options Max.100mA/DC24V; RS485
<b>CURRENT CONSUMPTION</b>	≤ 200mA ( 12VDC)	<b>CIRCUIT PROTECTION</b>	Short-circuit protection, reverse polarity protection, over-load protection
<b>SENSOR HEAD CONNECTIONS</b>	MAX 2, M8-4pin connector	<b>MEASURED VALUE</b>	0~9.999mm -9.999~0mm
<b>SENSOR HEAD COMMUNICATION</b>	RS485	<b>DISTANCE ADJUSTMENT</b>	Key setting
<b>INDICATOR</b>	Power:green/red Output/teaching:orange	<b>HOUSING</b>	PC
<b>AMBIENT TEMPERATURE</b>	-10...+50°C/35~85%RH (No condensation or icing)	<b>PROTECTION</b>	IP50
<b>STORAGE TEMPERATURE</b>	-20...+60°C/35~85%RH (No condensation or icing)		

## DIMENSIONS

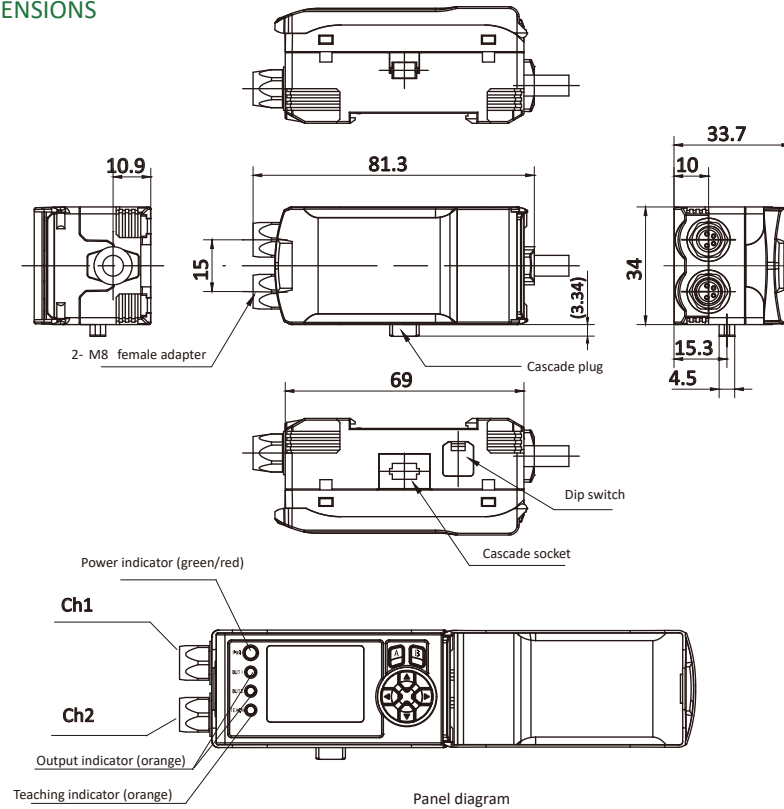

## Line sequence and wiring diagram

	Function	Color
1	V+ 12...24VDC	Brown
2	GND	Blue
3	NPN/PNP1	Yellow
4	NPN/PNP2	White
5	485A	Pink
6	485B	Green

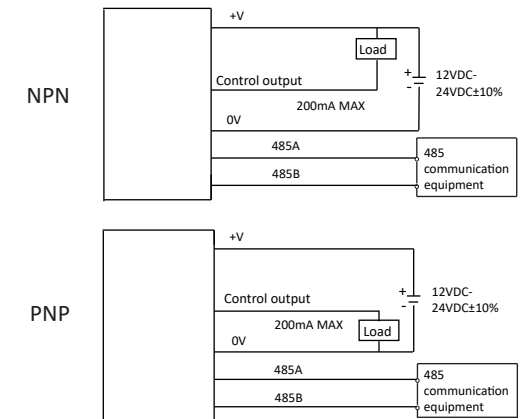

产品说明:

- OSC1系列控制器搭配OSMT60纠偏传感器一起使用, 带有按键示教功能, 多种工作模式可选, 同时具有多种输出类型。

产品特点:

- 精度高感应器控制器分开安装
- 支持多种检测模式, 多场景应用
- 搭载OLED显示屏, 中英文可选



型号	输出	感应头接线方式	感应头接线台数	连接方式
OSC1-UC2B6-Q8/485	NPN/PNP+485	M8 4针连接器	MAX.2	2M线缆

技术参数

工作电压	10...24VDC	分辨率	1μm
纹波电压	±10% of U	输出类型	2路PNP/NPN可选 Max.100mA/DC24V; RS485
消耗电流	200mA以下(12VDC)	保护电路	短路保护 反极性保护 输出过载保护
感应头连接	Max.2,M8 4针连接器	防护等级	IP50
感应头通信	RS485	外壳	PC
指示灯	电源指示灯:绿/红 输出指示灯/示教指示灯:橙	测量值	0~9.999mm/-9.999~0mm
工作温度	-10...+50°C/35~85%RH (无结露·结冰)	距离调节	按键设置
储存温度	-20...+60°C/35~85%RH (无结露·结冰)		

外型尺寸及部位说明

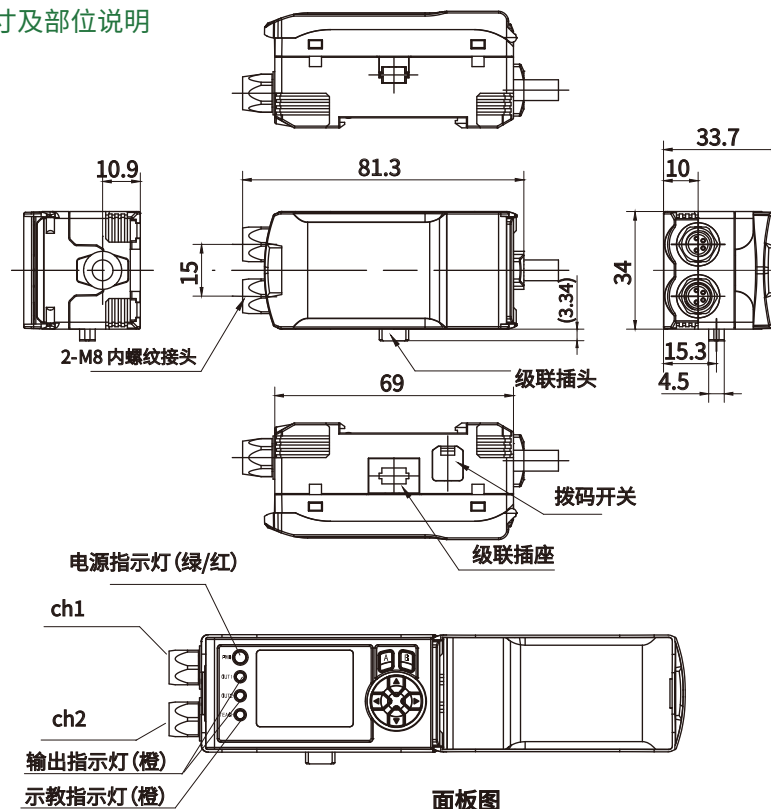

线序及接线图

	功能	线芯颜色
1	电源正	棕
2	电源负	蓝
3	NPN/PNP1	黄
4	NPN/PNP2	白
5	485A	粉
6	485B	绿

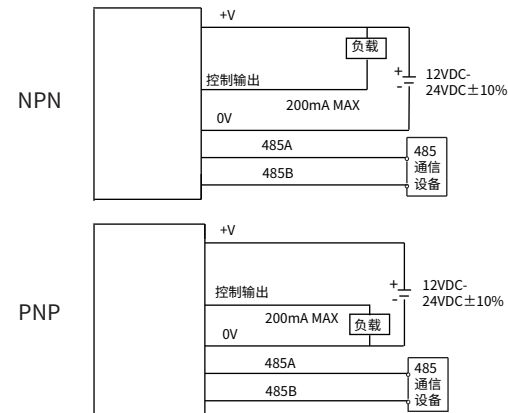

Operation guide

Menu flow chart and summary

Press the up and down keys to select the channel to be set, and press the "A" key to enter the setting interface.

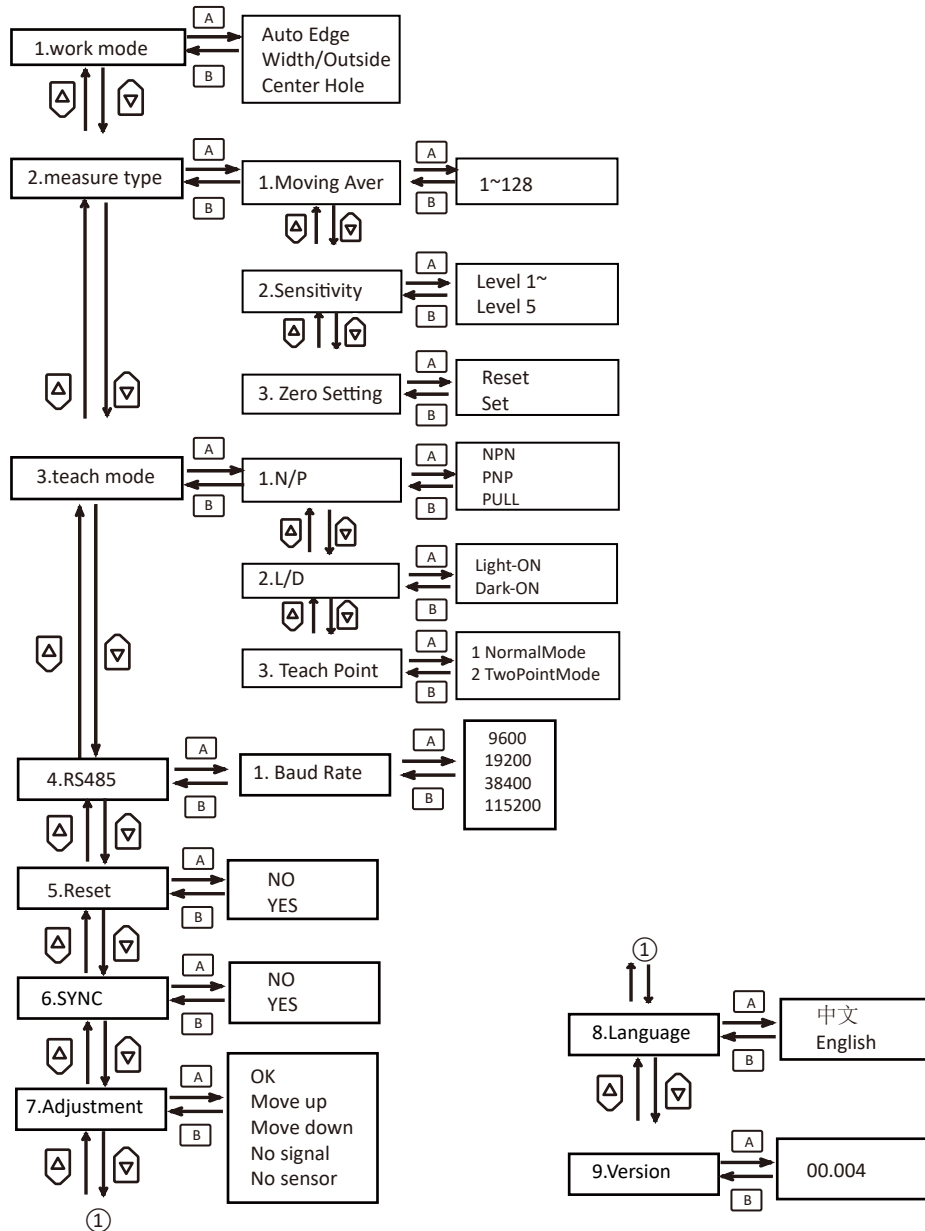

Controller operating instructions

1) Key description

▲ ▼ ◀ ▶ There are up,down,left and right, A confirm key, B return key.

2) Dual channel display mode

Default dual channel display mode,if it is not connected, display“----”and the power indicator is red.When a channel is connected to the sensor,the power indicator is green and the channel displays data.

3) Display mode switching

Enter the channel selection interface through the left and right keys.

Switch channels through the up and down keys, press the "A" key to confirm, and press the "B" key to return the dual channel display mode.

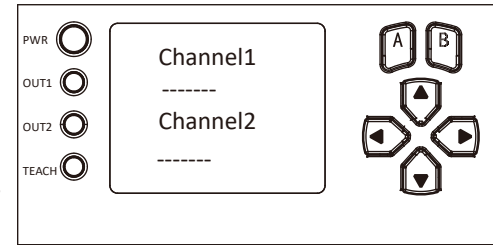

Setting instructions

work mode

Auto Edge(default) /Width/Outside/Center Hole

1)Auto Edge

Measuring the edge (end face) of an object.

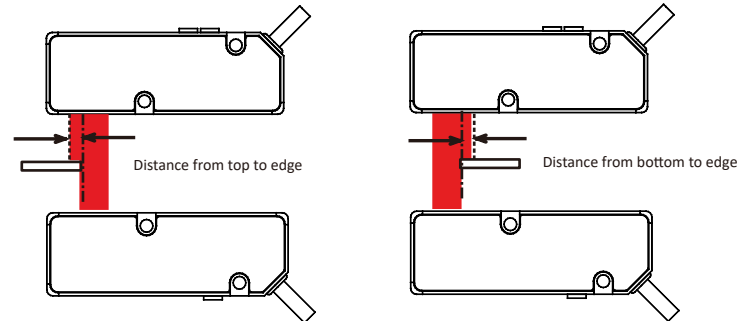

Entry direction of the measured object: it is ok to enter from the top/bottom.When the object enters from the top of the sensor, the measured value is the distance from the top of the sensor to the edge of the object and is positive, and the displayed value is 0~9.999.When the object enters from the bottom of the sensor, the measured value is the distance from the bottom of the sensor to the edge of the object and is negative, and the displayed value is 0~-9.999. When there are more than 2 edges in the measuring range, it cannot be measured.

2)Width/Outside

Measure the distance between two edges, such as width, outer diameter, etc.

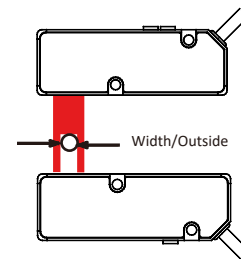

When both ends of the object are in the middle of the sensor, the measured value is its width value. When there is only one edge in the measuring range, or there are more than three cases, it cannot be measured.

### 操作指南

#### 菜单流程图及概要

按下下键选择需要设置的通道，按“A”键进入设置界面。

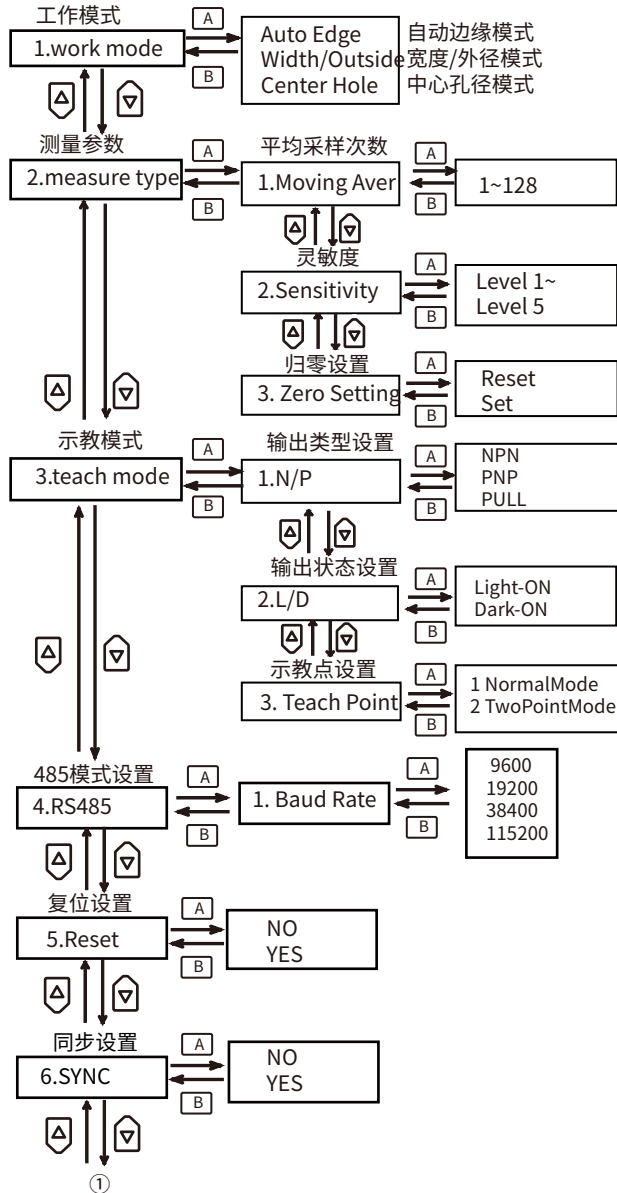

### 控制器操作说明

#### 1) 按键说明

▲ ▼ ▲ ▼ 左右键，为确认键，为返回键

#### 2) 双通道显示模式

默认双通道显示模式，如未接入则显示“---”，电源指示灯为红色，某一通道接入感应器接收端时，电源指示灯为绿色，同时该通道显示数据。

#### 3) 显示模式切换：

通过左右键进入单通道选择界面。

通过上下键切换通道，按“A”键确认，按“B”键返回常规双通道模式。

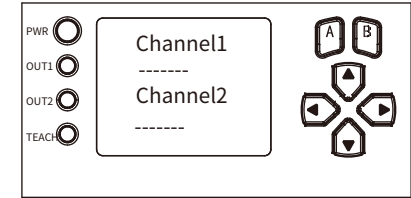

### 设置项目详细说明

#### 工作模式

工作模式有自动边缘模式(默认)、宽度/外径模式、中心孔径模式。

#### 1) 自动边缘模式

测量物体的边缘(端面)时，工作模式选择Auto Edge。

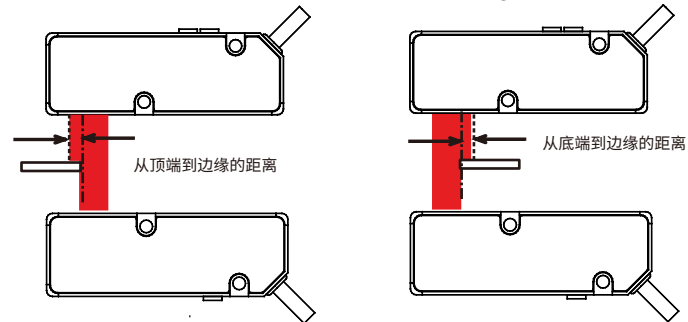

被测物的进入方向：自顶部/底部而入都是可以的。

当被测物由传感器顶端进入时，测量值为传感器上端到被测物边缘的距离且为正数，显示值为0~9.999。当被测物由传感器底端进入时，测量值为传感器下端到被测物边缘的距离且为负数，显示值为0~-9.999。在测量范围内存在2个以上的边缘时，不能测量。

#### 2) 宽度/外径模式

测量2个边缘之间的距离，如宽度、外径等，工作模式选择Width/Outside。

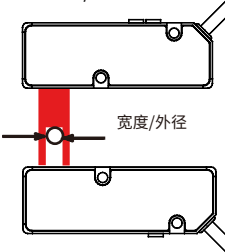

当被测物两端均处于传感器中间时，测量值为其宽度值。在测量范围内只存在1个边缘，或者有3个以上的情况时，不能测量。

3)Center Hole

Measure the distance between two edges, such as spacing, aperture, etc.

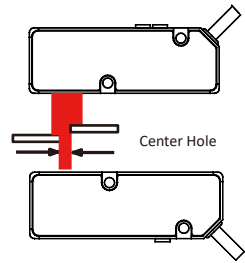

When the object covers the sensor and the gap part is in the middle of the sensor, the working mode is selected as the Center Hole, and the measured value is its aperture value.  
When there is only one edge in the measuring range, or there are more than three cases, it cannot be measured.

4)Other instructions

- A. When the sensor does not detect the object, the measured value is "-----".
- B. When the sensor is fully covered and does not meet the normal working scene, the measured value of 10000 indicates full occlusion.
- C. When the sensor is not fully covered and does not meet the normal working scene, the measured value of 20000 indicates the use error.

Measurement parameter setting Moving Aver

1) Average sampling times

Sets the number of times the measured values are averaged.  
Increasing the set value can effectively suppress the output jitter. It can be set to 1-128 numbers for moving average, and the default value is 10 (serving 485 communication, switch output and EC module).  
When the average sampling number is set to 1, the averaging process is not performed.  
When it cannot be measured, the average processing data will not be updated.

2)Sensitivity

Sensitivity can be set in five levels.  
In general, the sensitivity can be detected normally in the initial state [level 3].  
If the measurement is unstable due to the long distance between the receiver and the emitter, please increase the sensitivity. In addition, please reduce the sensitivity when the laser penetrates the object and the measurement is unstable.

3)Zero setting

This setting is only for Auto Edge.  
Set the current measured value to zero, so that the currently displayed measured value is displayed as 0. select "reset" to cancel the zero setting, restore the measured value to the actual state .

Teaching mode

This mode setting is suitable for switching output.

1)Output mode setting

N/PSet: can be set NPN,PNP and push-pull output.

2)Output status setting

L/DSet: can be set light on "L-ON" and dark on "D-ON".

3)Teaching mode setting

This setting can only be set in Auto Edge.

a. NormalMode (default)

Measure a single object and set a judgment value.

b. TwoPointMode

Measure two objects and set the upper and lower limits.

Used when making decisions within the upper and lower limits.

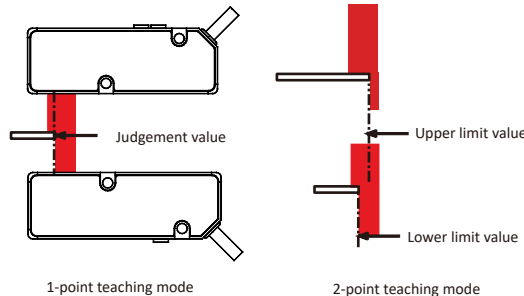

485 configuration

BaudSet:9600/19200/38400/115200.

Reset

Reset function, which restores all configurations of this channel to factory setting mode.

Default:Auto Edge, Average sampling times is 10, sensitivity level 3, zero setting -10/0, NPN,L-ON, P1 is 5, P2 is 0.

Remarks: Channel 1 and Channel 2 are the above default parameters.

BaudSet and Language setting have no default parameters.

SYNC

Synchronization, which copies the contents of another channel directly to that channel.

Adjustment

Adjust the position according to the display prompt.

Adjust the position of the emitter, namely, up, down, OK, no signal and no sensor.

Language

Switch between Chinese and English.

Version

Query the current software version.

Optional accessories

Connecting cable between sensor and controller

ECS-C8.4-0.3-2CO8.4-2/2/P44

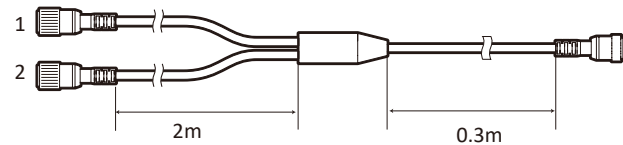

ECS-C8.4-2-2CO8.4-0.3/0.3/P44

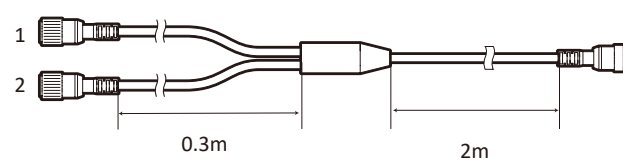

CO8.4-2-C8.4

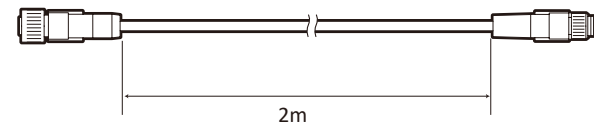

ECS-ECO8.4/P44

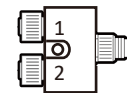

3) 中心孔径模式  
测量2个边缘之间的距离，如间距，孔径等。

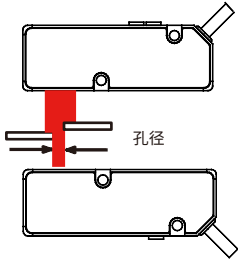

当被测量物覆盖传感器且间隙部分处于传感器中间时，工作模式选择CenterHole，测量值为其孔径值。在测量范围内只存在1个边缘，或者有3个以上的情况时，不能测量。

4) 其他说明

- a. 传感器没有检测到被测物时，测量值为”-----”。
- b. 传感器被全覆盖且不满足正常工作场景时，测量值为10000表示全遮挡。
- c. 传感器未被全覆盖且不满足正常工作场景时，测量值为20000表示使用错误。

测量参数设定

1) 平均采样次数

设定测量值平均化处理的次数。增大设定值可有效抑制输出的跳动。  
可设置为1-128个数做滑动平均，默认值为10（服务于485通信，开关量输出，EC模块）。  
平均采样次数设定为1次时，则不执行平均化处理。不能测量的时候，不会更新平均化处理数据。

2) 灵敏度

灵敏度分5个等级可设定。  
一般情况下，灵敏度在初始状态[3级]下可正常检测。  
如果因为接收器和发射器之间距离较大等因素导致测量不稳定时，请增大灵敏度。  
另外，激光穿透被测物体导致测量不稳定时，请减小灵敏度。

3) 归零设定

此设定只针对于边缘模式。  
将当前的测量值执行归零设定，使得当前显示测量值显示为0取消归零设定，选择“reset”将测量值恢复到实际状态。

示教模式

此模式设定适用于开关量信号设定。

1) 输出类型设置

N/PSet: 输出方式设定，可设置为NPN输出，PNP输出，PULL推挽输出

2) 输出状态设置

L/DSet: 亮暗态设定，可设置为L-ON亮通，D-ON暗通。

3) 示教模式设置

- 此设置只能在自动边缘模式下进行设定。
- a. NormalMode 常规模式 --1点教导模式（默认）  
测量单个工件，设定判定值。
  - b. TwoPointMode -----两点教导模式  
测量两个工件，设定上、下限值。  
在上限和下限范围内进行判定时使用。

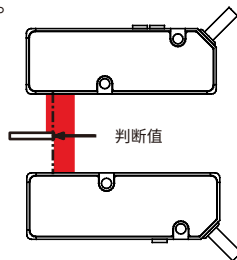

1点教导模式图示

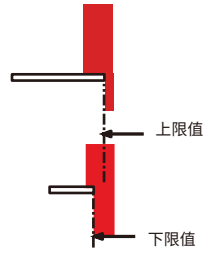

2点教导模式图示

485配置

BaudSet: 波特率设定，可设置为9600/19200/38400/115200。

复位功能

Reset: 复位功能，将该通道的所有配置恢复至出厂设置模式  
参数为：自动边缘，平均采样次数为10，灵敏度为3级，零点为-10/0，NPN,亮通，P1为5，P2为0。  
备注：通道1和通道2均为上述出厂默认参数。485波特率与语言设置无出厂默认参数。

同步功能

SYNC: 同步，将另一通道内容直接复制到该通道。

调教模式

Adjustment 调教模式，可根据显示屏提示进行位置调整，调整发射端位置，分别为向上、向下、OK、无信号、无传感器。

语言设置

Language 语言设置，可进行中英文切换。

版本

Version 可通过版本查询当前软件版本。

### 可选购配件

传感器与控制器间的连接线缆

ECS-C8.4-0.3-2CO8.4-2/2/P44

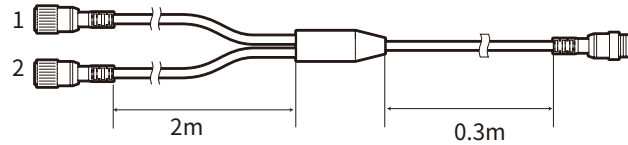

ECS-C8.4-2-2CO8.4-0.3/0.3/P44

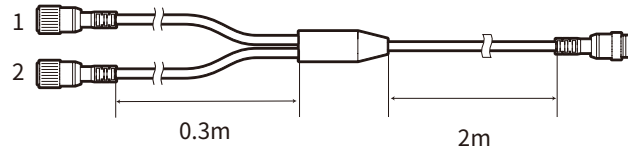

CO8.4-2-C8.4

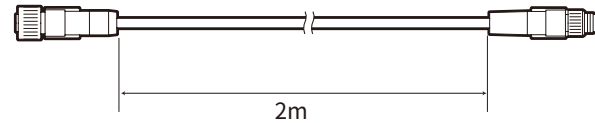

ECS-ECO8.4/P44

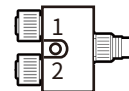

**Cautions**

- The OSC1 controller should be used in combination with OSMT60 sensor. If combination with other sensor, it may cause product failure.
- Please warm up the products for 30 minutes before use.
- Please turn off the power supply when the cable is routed or disconnect, otherwise it may cause product failure.
- Please don't connect it in parallel with the high-voltage line or power cord, otherwise the product may malfunction or be damaged due to electromagnetic induction.
- Please do not bend the cable at freezing temperature to avoid damaging the product.
- Please do not strongly impact the product or fall from a height to avoid damaging the product.
- When wiring this product with the sensor, please follow this instructions or the sensor instructions. Incorrect wiring may lead to misoperation or failure of the product or sensor.
- When the connector is exposed, do not touch the pins in the connector port, and foreign objects are prohibited from entering the interior.
- Please separate high-voltage equipment, power supply equipment, machines that generate large switching current, welding motors, welding machines and other equipment that generate interference.
- When connecting or disconnecting the cable, please apply force to the connector part, and do not apply excessive force to the cable.
- Please do not touch the product and cable with wet hands to avoid damaging the product.
- Please use the product and controller within the rated output power range.
- Please wait 3s after changing the operation settings, and then cut off the power supply.

**485 communication instructions**

**Communication format**

1 Modbus RTU Big-Endian

2 Communication interface:RS485 with baud rate of 115200bps(settable).

8 data bits,1 start bit,1stop bit,no parity.

3 Format

Serial number	Device address	Function code	Data	CRC
1	1BYTES	1BYTES	NBYTES	2BYTES(CL,CH)

Remarks:

1.Device address:

The upper 4 digits are the hardware address of the equipment, corresponding to dip switch, ranging from 0 to 7, as shown in the table.Dials 1, 2 and 3 are address bits, and 4 is reserved bit.

The low four bits are that actual connection address,Bit 0-3 corresponds to one channel per bit.

For example, the address of channel 1 of device 1 is 0x11;The channel 2 address of device 7 is 0x72.

2. The data length is N, and the maximum length is 252.

3.CRC : using CRC16, initial value: polynomial 0xFFFF,Polynomial:0xA001 CRC is the low byte before and the high byte after.In the example, CL stands for low byte and CH stands for high byte.

1	2	3	Equipment	1	2	3	Equipment
000	0	001	4				
100	1	101	5				
010	2	011	6				
110	3	111	7				

**4 Modbus function code description**

Serial number	Function declaration	Function code	Explain
1	Read register	0x03	----
2	Write register	0x06	

**5 Example**

**Register reading**

Serial number	Description of parameter	Data content	Explain	Example
1	Function code	0x03	Only single register reads are supported.	0x01 0x03 0x00 0x81 0x00 0x01 CL CH
2	Start address	0x0000~0xFFFF		
3	Number of registers N	0x01		

**Register read reply**

Serial number	Description of parameter	Data content	Explain	Example
1	Function code	0x03	----	0x01 0x03 0x02 0x00 0x00 CL CH
2	Number of bytes, 1BYTE	N*2		
3	Register value	N*2 BYTES		

**Single register write**

Serial number	Description of parameter	Data content	Explain	Example
1	Function code	0x06	----	0x01 0x06 0x00 0x81 0x00 0x01 CL CH
2	Register address	0x0000~0xFFFF		
3	Register value	0x0000~0xFFFF		

**Single register write reply**

Serial number	Description of parameter	Data content	Explain	Example
1	Function code	0x06	The reply command is the same as the issue command.	0x01 0x06 0x00 0x81 0x00 0x01 CL CH
2	Register address	0x0000~0xFFFF		
3	Register value	0x0000~0xFFFF		

注意事项

- 本产品需要与OSMT60传感器配合使用，如与其他传感器一起使用可能会造成产品故障。
- 请使用专用线缆连接本产品，避免误动作或产品故障。
- 连接传感器后请预热30分钟后使用。
- 进行电缆布线或连接器脱落时请关闭电源，否则可能会导致故障发生。
- 请不要与高压线或电源线并联，否则可能会因电磁感应而导致本产品发生误动作、损坏。
- 请勿在冰点温度状态下弯曲电缆线，避免损坏产品。
- 请勿强烈撞击本产品，或从高处掉落，避免损坏产品。
- 本产品与传感器进行接线时，请按照本说明书或指定说明书的相关说明进行接线。错误接线可能会导致产品或传感器发生误动作或故障。
- 相关连接器外露时，请勿触碰连接器端口内的引脚，禁止异物进入内部。
- 请将高压设备、电源设备、产生大的开关电流的机器、电焊机、焊接机等产生干扰的设备分开放置。
- 当连接或断开电缆时，请施力在连接器部分上，不要对电缆施加过大的力。
- 请在额定输出功率范围内使用本产品与专用传感器。
- 产品工作时发热，请不要长时间触摸。避免低温烫伤。
- 请在变更操作设置后等待3s，再做电源切断动作。

通讯说明

通讯格式

1 modbus RTU方式,大端模式。

2 通讯接口:RS485,波特率115200bps(可设置)。

8位数据位,1位起始位,1位停止位,无奇偶校验。

3 通讯格式

序号	设备地址	功能码	数据	CRC校验
1	1BYTES	1BYTES	NBYTES	2BYTES(CL,CH)

备注:

1.设备地址:

高4位为设备硬件地址,对应拨码开关,范围0~7,如下表所示,拨码1、2、3为地址位,4为预留位。

低4位为实际连接地址,bit0-3每个位对应一个通道。

例如:设备1的通道1地址为0x11;设备7的通道2地址为0x72

2.数据长度N,最大长度为252。

3.CRC校验:使用CRC16,初始值:多项式0xFFFF,多项式:0xA001。CRC是低字节在前,高字节在后。

下述示例中CL代表低字节,CH代表高字节。

1	2	3	对应设备	1	2	3	对应设备
0	0	0	000	0	0	0	4
0	1	0	100	0	1	0	5
0	1	1	010	0	1	1	6
0	1	1	110	0	1	1	7

4 modbus功能码说明

序号	功能说明	功能码	说明
1	读寄存器	0x03	无
2	写寄存器	0x06	

5 示例

寄存器读取

序号	参数说明	数据内容	说明	例子
1	功能码	0x03	仅支持单寄存器读取	0x01 0x03 0x00 0x81 0x00 0x01 CL CH
2	起始地址	0x0000~0xFFFF		
3	寄存器数量N	0x01		

寄存器读取回复

序号	参数说明	数据内容	说明	例子
1	功能码	0x03	无	0x01 0x03 0x02 0x00 0x00 CL CH
2	字节数,1BYTE	N*2		
3	寄存器值	N*2 BYTES		

单寄存器写入

序号	参数说明	数据内容	说明	例子
1	功能码	0x06	无	0x01 0x06 0x00 0x81 0x00 0x01 CL CH
2	寄存器地址	0x0000~0xFFFF		
3	寄存器值	0x0000~0xFFFF		

单寄存器写入回复

序号	参数说明	数据内容	说明	例子
1	功能码	0x06	回复指令与下发命令相同	0x01 0x06 0x00 0x81 0x00 0x01 CL CH
2	寄存器地址	0x0000~0xFFFF		
3	寄存器值	0x0000~0xFFFF		

Register description

Serial number	Register name	Data description		
		Register address	Length (bytes)	Content
1	Dist	0x0000	2	BYTE0-1: the output result of the sensor , which is the distance value for this sensor.
2	Version	0x0080	2	Version number
3	Work mode	0x0081	2	0: Auto Edge;1: Width/Outside 2: Center Hole
4	Average sampling times	0x0082	2	Set the number from 1 to 128 for moving average.
5	Sensitivity	0x0083	2	Setting 0-4 corresponds to a sensitivity of 1-5
6	Output mode of teaching mode	0x0084	2	0:NPN;1:PNP;2:Push-pull
7	L/D mode of teaching mode	0x0085	2	0:L-ON;1:D-ON
8	P1 of teaching mode	0x0086	2	null
9	P2 of teaching mode	0x0087	2	null
10	Baud rate of RS485	0x0088	2	0:9600;1:19200;2:38400;3:115200
11	Zero setting	0x0089	2	1.Zero setting; 2.Reset
12	Data update flag bit	0x008A	2	When peripherals other than 485 modify the controller configuration, this flag bit will be set to 1, and it will be cleared automatically after query. It is suggested that 485 visit this register periodically, and synchronize all settings when there is data update before continuing to use it.

寄存器说明

序号	寄存器名称	数据说明		
		寄存器地址	长度(字节)	内容
1	Dist	0x0000	2	BYTE0-1:传感器的输出结果, 对于此传感器为距离值
2	版本	0x0080	2	版本号
3	工作模式	0x0081	2	0:边缘模式;1:宽度模式 2:孔径模式
4	平均采样次数	0x0082	2	设置1-128个数做滑动平均
5	灵敏度设置	0x0083	2	设置值为0-4对应1-5灵敏度
6	示教模式的输出方式设定	0x0084	2	0:NPN;1:PNP;2:Push-pull
7	示教模式的亮暗通设定	0x0085	2	0:亮通;1:暗通
8	示教模式的P1点	0x0086	2	null
9	示教模式的P2点	0x0087	2	null
10	RS485的波特率设置	0x0088	2	0:9600;1:19200;2:38400;3:115200
11	零点	0x0089	2	1.设置零点;2.清除零点
12	数据更新标志位	0x008A	2	当除485之外的外设修改控制器配置时, 该标志位会置1, 查询之后会自动清零。建议485周期性访问该寄存器, 有数据更新时同步所有设置再继续使用。