

Product Description:

- High performance small square photoelectric sensor
- Suitable for applications such as logistics, textiles, glass machinery, food packaging, etc.

Product features:

- BGS can provide detection distance products for linear array light sources
- Red light source

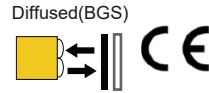

Type	Distance	Beam	Output	Connection	Wiring
OS20-AK300CP6 *M <sup>1)</sup>	6...300mm	Red	NPN	Cable	Fig.1
OS20-AK300CP6Q8	6...300mm	Red	NPN	M8 Connector	Fig.2
OS20-AK300CN6 *M <sup>1)</sup>	6...300mm	Red	PNP	Cable	Fig.3
OS20-AK300CN6Q8	6...300mm	Red	PNP	M8 Connector	Fig.4

Note 1): \* M refers to the cable length in meters. If there is no \* M in the model, the default cable length is 2 meters.

TECHNICAL SPECIFICATION

<b>OPERATING VOLTAGE</b>	10...30 V DC	<b>AMBIENT TEMPERATURE OPERATION</b>	-25°C...+55°C
<b>RIPPLE VOLTAGE</b>	±10% of U <sub>B</sub>	<b>AMBIENT TEMPERATURE STORAGE</b>	-40°C...+70°C
<b>LIGHT SOURCE TYPE</b>	Red LED	<b>CIRCUIT PROTECTION</b>	Short-circuit protection, reverse polarity protection, over-load protection
<b>OUTPUT CHARACTERISTIC</b>	PNP/NPN	<b>PROTECTION DEGREE</b>	IP67
<b>LOAD CURRENT</b>	≤100mA	<b>HOUSING MATERIAL</b>	PC+PBT
<b>SWITCHING FREQUENCY</b>	400Hz	<b>CONNECTING TYPE</b>	*m PVC cable M8 Connector

DIMENSIONS

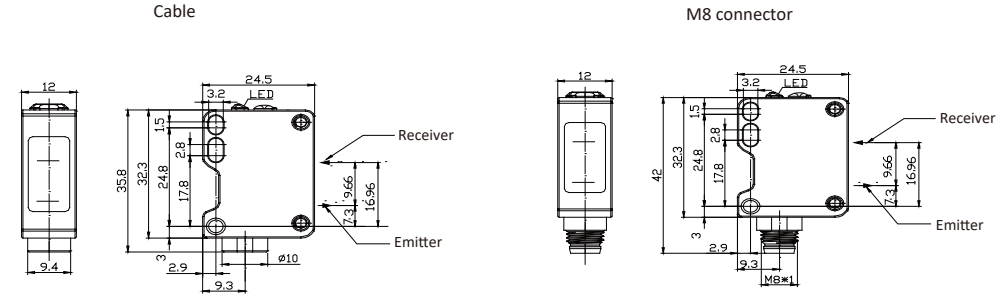

INDICATORS

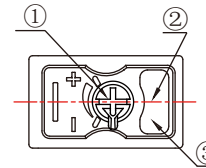

①	Detection distance adjuster	
②	Output indicator	Yellow
③	Stable indicator	Green

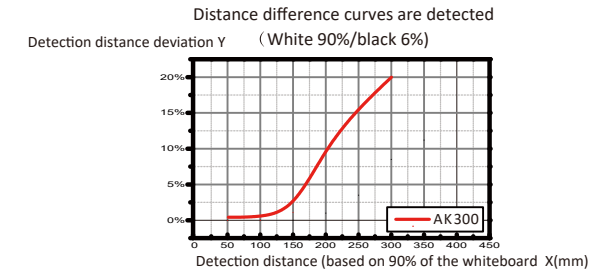

ELECTRICAL CONNECTION

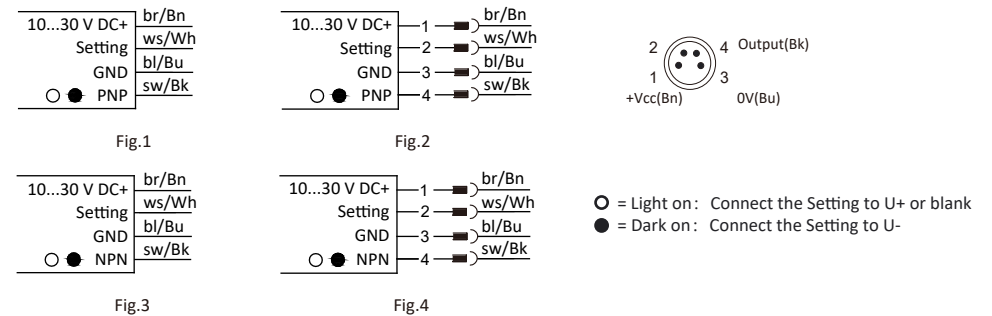

## 产品说明:

- 高性能小方形光电传感器
- 适用于物流, 纺织, 玻璃机械, 食品包装等应用。

## 产品特点:

- BGS可提供线阵光源的检测距离产品
- 红光光源



型号	检测距离	光源	输出方式	连接方式	接线图
OS20-AK300CP6 *M <sup>1)</sup>	6...300mm	红光	NPN	线缆	图1
OS20-AK300CP6Q8	6...300mm	红光	NPN	M8 连接器	图2
OS20-AK300CN6 *M <sup>1)</sup>	6...300mm	红光	PNP	线缆	图3
OS20-AK300CN6Q8	6...300mm	红光	PNP	M8 连接器	图4

注1): \*M表示线缆长度, 单位米, 型号中无\*M默认线缆长度为2米。

## 技术参数

工作电压	10...30 V DC	工作温度	-25°C...+55°C
纹波电压	±10% of U <sub>B</sub>	环境温度	-40°C...+70°C
光源	红光 LED	保护电路	短路保护 反极性保护 输出过载保护
输出特性	PNP/NPN	防护等级	IP67
负载电流	≤100mA	外壳	PC+PBT
开关频率	400Hz	连接方式	*m PVC 线缆 M8 连接器

## 外形尺寸

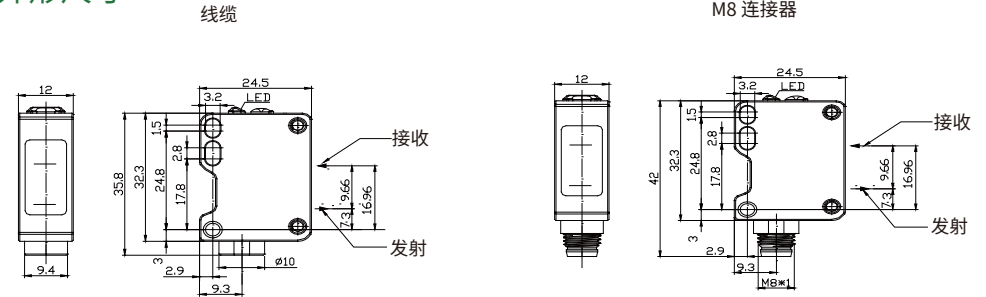

## 操作指示

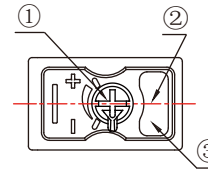

①	检测距离调节	
②	开关动作指示灯	黄色
③	电源稳态指示灯	绿色

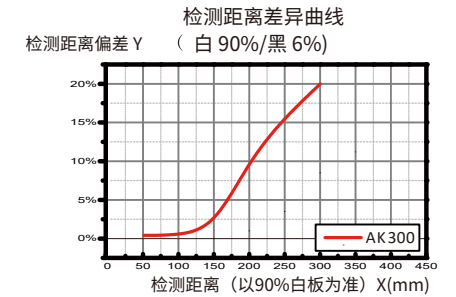

## 接线图



图1



图2

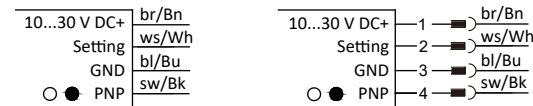

图3

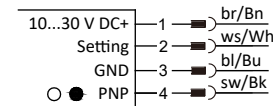

图4

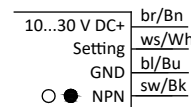
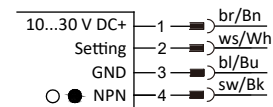
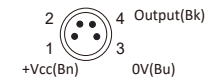

- =亮通: Setting 接 U+或置空
- =暗通: Setting 接 U-