

产品说明

- Type 4, SIL3
- LED显示工作状态, 通道1, 通道2
- 外形尺寸: 22.5×99×114 mm

产品特点

- 单,双通道输入可选
- 自动手动复位可选
- 通道交互监控功能
- 外部回路监控功能
- 适用于安全光幕、急停按钮、安全门监控等



型号	功能	供电电压	输入通道	安全输出	辅助输出
SR22-31/24VUC/ ESC	急停模块	24 V DC / AC	2	3	1

安全参数

安全等级	Type 4 (IEC61496-1)	安全类别	Category 4 (ISO13849-1)
安全完整性等级	SIL 3 (IEC61508)	安全性能等级	PLe (ISO13849-1)

技术参数

工作电压	24 V DC / AC	接通延时手动启动	30 ms
纹波电压	≤ 20 %	接通延时自动启动	300 ms
停止类别	Stop 0 (IEC 60204-1)	释放时间-额定电压	≤ 20 ms
每小时一个危险停止运转的平均可能性(PFH)	1.48×10^{-9}	信号序列监测窗口时间	20 ms
平均无故障时间 (MTTF)	3867 年	S12, S22和S31控制电压/电流	24 V DC / 70 mA
最大输入电流	150 mA	允许输入导线电阻	< 30 Ω
功率消耗	4 W	使用寿命	20 年
供电电路外部保护装置	200 mA 延迟动作	过电压等级	III 类测定电压300 V AC
触点开关能力	1.4 × 10 ⁵ (1NO: 6 A 30 V AC, 阻性负载, 85 °C 1 s 通9 s 断) 1.4 × 10 ⁵ (1NO: 6 A 250 V AC, 阻性负载, 85 °C 1 s 通9 s 断)	机械寿命	1 千万开关循环次数
触点切换电流	阻性负载: 最大值3 A, 外部保险适用3 A 240 V AC (AC-15): 额定1.5 A, 外部保险适用 2.5 A 24 V DC (DC-13): 额定1 A, 外部保险适用 1.5 A	端子类型	螺丝端子
		连接线缆	0.2 mm ² 至 0.5 mm ²
		重量	160 g

环境参数

储存温度	-40 ... +70 °C	污染等级	2
工作温度	-10 ... +55 °C	抗振动能力 (EN 60068-2-6)	频率10 ... 55 Hz, 振幅 1.5 mm, 双振动
防护等级	外壳 IP40 端子 IP20	抗干扰能力 (EN 61496-1)	4 类

标准与指令

EMC DIRECTIVE 2014/30/EU	EN IEC 61000-6-2 EN IEC 61000-6-4	ROHS DIRECTIVE 2011/65/EU	EN IEC 63000
--------------------------	--------------------------------------	---------------------------	--------------

认证



Product Description

- TYPE 4, SIL3
- LED shows working status, channel 1, channel 2
- Dimensions of form: 22.5 × 99 × 114 mm



Product Features

- Single and dual channel input is optional
- Automatic manual reset is optional
- Channel interaction monitoring function
- External loop monitoring function
- Suitable for safety light curtain, emergency stop button, safety door monitoring and so on.

Model	Description	Supply voltage	Input channel	Safety output	Auxiliary output
SR22-31/24VUC/ESC	Emergency Stop Module	24 V DC / AC	2	3	1

SAFETY-RELATED PARAMETERS

TYPE	Type 4 (IEC61496-1)	CATEGORY	Cat. 4 (ISO13849-1)
SAFETY INTEGRITY LEVEL	SIL 3 (IEC61508)	PERFORMANCE LEVEL	PLe (ISO13849-1)

TECHNICAL DATA

SUPPLY VOLTAGE	24 V DC / AC	PICK UP DELAY MANUAL START	30 ms
RIPPLE VOLTAGE	≤ 20 %	PICK UP DELAY AUTO START	300 ms
STOP CATEGORY	Stop 0 (IEC 60204-1)	RELEASE TIME-RATED VOLTAGE	≤ 20 ms
PFH	1.48 × 10 ⁻⁹	TIME WINDOW FOR SIGNAL SEQUENCE MONITORING	20 ms
MTTF	3867 years	CONTROL VOLTAGE / CURRENT ON S12, S22, S31	24 V DC / 70 mA
MAX INPUT CURRENT	150 mA	ADMISSIBLE INPUT LINE RESISTANCE	< 30 Ω
POWER CONSUMPTION	4 W	SERVICE LIFE	20 years
EXTERNAL SAFEGUARDING FOR SUPPLY CIRCUIT	200 mA delay-action	OVERVOLTAGE CATEGORY	III for rated operating voltage 300 V AC
SWITCHING CAPACITY OF THE CONTACTS	1.4 × 10 ⁵ (1NO: 6 A 30 V DC, Resistive load, 85 °C 1 s on 9 s off) 1.4 × 10 ⁵ (1NO: 6 A 250 V AC, Resistive load, 85 °C 1 s on 9 s off)	MECHANICAL LIFE TIME	10 million switching cycles
SWITCHING CURRENT OF THE CONTACTS	Resistive load: max. 3 A, External fuse 3 A 240 V AC (AC-15); rated 1.5 A, External fuse 2.5 A 24 V DC (DC-13); rated 1 A, External fuse 1.5 A	TYPE OF TERMINAL	Screw terminal
		CONNECTION CROSS SECTIONS	0.2 mm ² to 0.5 mm ² wire
		NET WEIGHT	160 g

ENVIRONMENTAL CONDITIONS

STORAGE TEMPERATURE	-25 ... +70 °C	DIRT LEVEL	2
AMBIENT TEMPERATURE	0 ... +55 °C	VIBRATION RESISTANCE (EN 60068-2-6)	Frequency 10 ... 55 Hz, amplitude 1.5 mm, dual vibration
PROTECTION CLASS	Housing IP40 Terminals IP20	INTERFERENCE RESISTANCE (EN61496-1)	Type 4

STANDARDS AND DIRECTIVES

EMC DIRECTIVE 2014/30/EU	EN IEC 61000-6-2 EN IEC 61000-6-4	ROHS DIRECTIVE 2011/65/EU	EN IEC 63000
---------------------------------	--------------------------------------	----------------------------------	--------------

APPROVALS



接线图

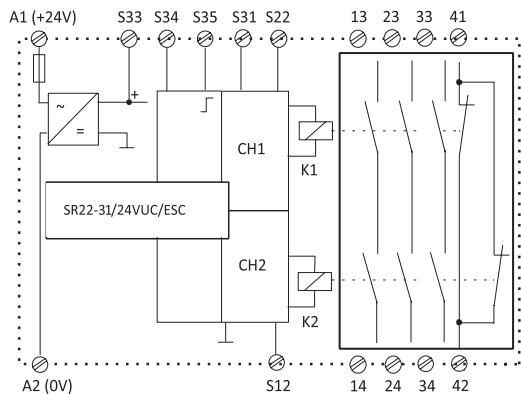

外形尺寸



图1: 接线举例 1



图2: 接线举例 2

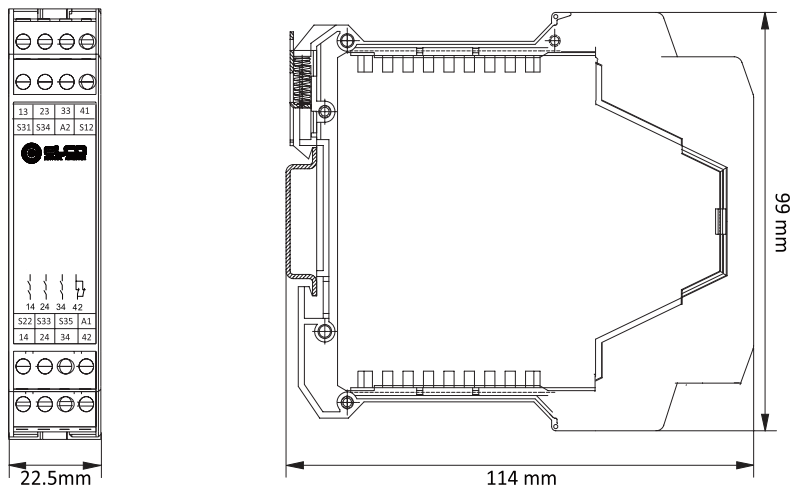

图3: 接线举例 3

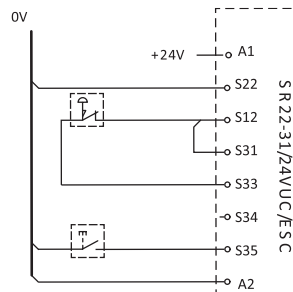

图4: 接线举例 4

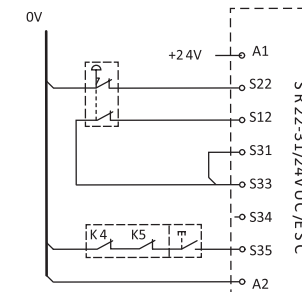

图5: 接线举例 5

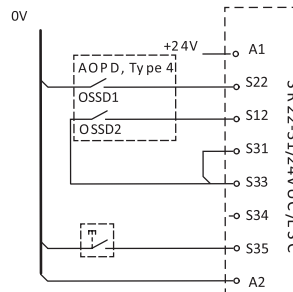

WIRING DIAGRAMS

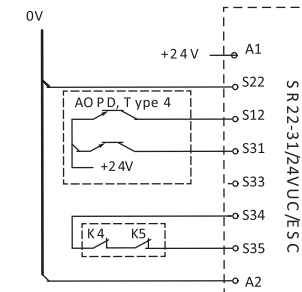
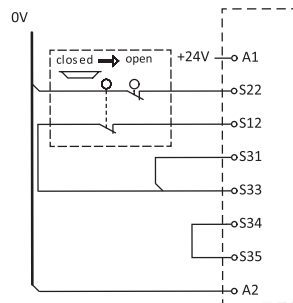
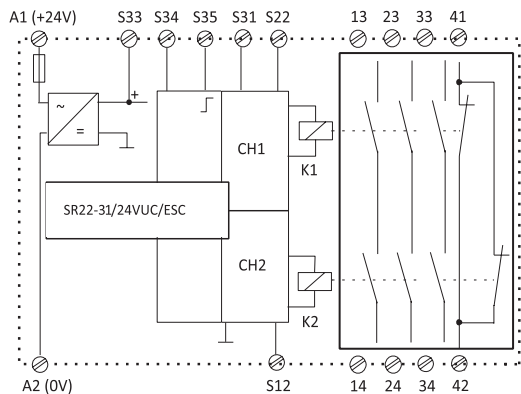

DIMENSIONS

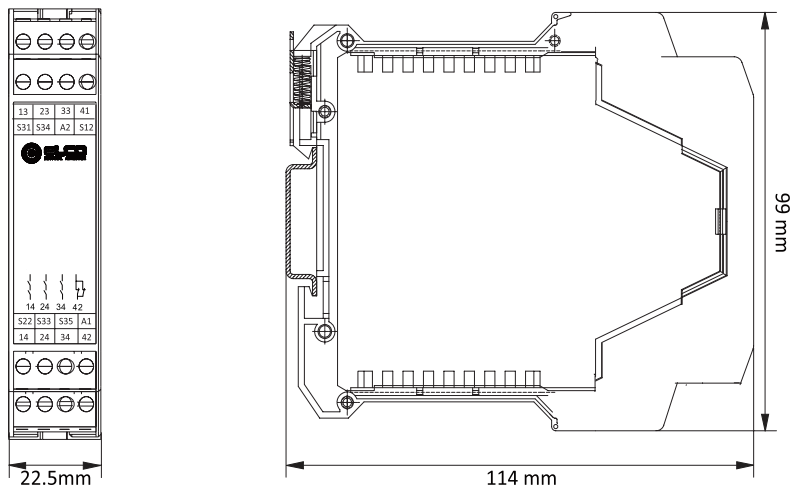

Figure 1: Connection example 1

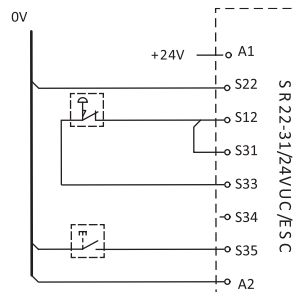

Figure 2: Connection example 2

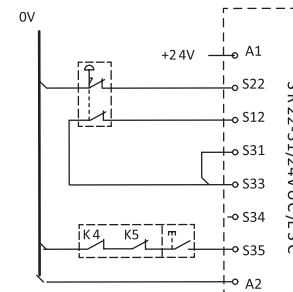

Figure 3: Connection example 3

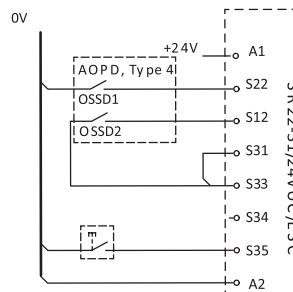

Figure 4: Connection example 4

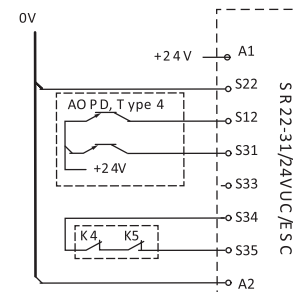
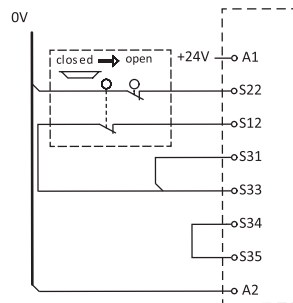

Figure 5: Connection example 5



• 单通道急停布线，手动启动（参见图1）

在 A1 和 A2 接通电压后以及没有操作急停按钮时，通过按压启动按钮使继电器 K1 和 K2 关闭，并自动保持这种状态。释放电路 13-14, 23-24 和 33-34 闭合, 信号回路 41-42 打开。通过操作急停按钮切断了 K1 和 K2 的电源, K1 和 K2 打开。释放电路打开, 信号回路闭合。通过单通道急停布线可以达到第 2 类, 按照 EN ISO 13849-1:2009。按钮回路中的接地被识别。

• 双通道急停布线，手动启动（参见图2）

功能/作用原理如上所述。此外在启动回路(复位)中连接了接触器触点 K1 和 K2 (EDM)。

通过双通道急停布线可以达到第 4 类, 按照 EN ISO 13849-1:2009。

• 用于光电保护装置(第4类EN 61496-1)的安全随动控制系统(参见图3)，(参见图4)

第 4 类安全光栅可以选择继电器输出(参见图 3) 或者自动防故障半导体输出(参见图 4) 连接。在计算安全距离时必须将 SR22-...ESC 的回复延迟 10ms 计算在内。除了启动回路外也可以选择 S34 和 S35 之间架桥, 用于自动启动。对于这种运行方式必须排除从后面到达和进入安全光栅的可能性。

• 双通道滑动保护栅栏监测(参见图5)

在使用 2 个驱动限位开关时, 根据预定的信号序列监测取决于方向的触点操作, 例如滑动保护栅栏。在自动启动(S34-S35 架桥)时必须排除从后面启动和进入的可能性。

• 信号序列监测

该功能等待 S22 的第一个信号和 S12 的第二个信号。可以任意选择这中间的时移。例如, 如果由于接触操作钥匙的失调而引起信号换错, 该信号的时移可达 20ms。20ms 后 SR22-...ESC 的释放电路关闭。信号序列监测只有在自动启动布线时才会被激活。EDM 信号必须比 S12 信号输入延迟 20ms (最大值)。

• 输出端 S 的监测

在 S12 和 S22 输入端跨电路或 S12 接地短路的情况下, 输出继电器 K1 和 K2 将通过一个电子保险装置关闭。在清除故障起因 2s 后, SR22-.../ESC 可以重新投入运行。

• 手动启动时启动按钮监测(参见图1)，(参见图2)，(参见图3)

为了辨别静态错误和启动按钮的阻塞, 对按钮功能进行信号变化监测。松开按钮就是启动(1/0-信号变化)。在自动启动(参见图 4 和 5) 时该功能被锁住。

• 手动启动时的接触器监测(EDM) (参见图2)

为了外部接触器的功能监测, 将这些接触器的常闭触点(K4 和 K5) 与启动按钮串联后接入启动回路 S35 中。

• 自动启动时的接触器监测(EDM) (参见图4)

为了外部接触器的功能监测, 将这些接触器的常闭触点(K4 和 K5) 在 S34 和 S35 之间串联后接入。

- **Single-channel E-STOP circuit, manual start (see figure 1)**

After applying the supply voltage to A1 and A2 and with the E-STOP button not actuated, relays K1 and K2 pick up upon actuation of the start button and lock. The release circuits 13-14, 23-24 and 33-34 close, signal circuit 41-42 opens. Upon actuation of the E-STOP button, K1 and K2 go dead and drop out. The release circuits open, the signal circuit closes. With one-channel E-STOP wiring, up to category 2 acc. to EN ISO 13849-1: 2009 is achieved. Earth faults in the button circuit are detected.

- **Two-channel E-STOP circuit, manual start (see figure 2)**

Function/operating principle as described above. In addition, contactor contacts K1 and K2 are looped into the start circuit (reset) (EDM). With two-channel E-STOP wiring, up to category 4 acc. to EN ISO 13849-1: 2009 is achieved.

- **Downstream safety circuit for optoelectronic protective devices type 4, EN 61496-1 (see figure 3), (see figure 4)**

Optionally, Light Beam Safety Devices of type 4 can be connected with relay outputs (see figure 3) or with fail-safe semiconductor outputs (see figure 4). When calculating the safety distance, the release time of the SR22 ...ESC must be included. As an alternative to the start circuit, a bridge can be placed between S34 and S35 for automatic start. With this operating mode, it must not be possible to reach step behind the Light Beam Safety Device.

- **Two-channel sliding safety guard monitoring (see figure 5)**

Based on the specified signal sequence, when using two, forced position switches, the direction dependent actuation of the contacts, e.g. of a safety guard, is monitored. For automatic start (bridge S34 - S35), reaching or stepping behind must not be possible.

- **Signal sequence monitoring**

The function expects the first signal at S22 and the second signal at S12. The time offset is arbitrary. If, due to e.g., misalignment of a contact actuator, the times of the signals are swapped, this is tolerated up to max. 20 ms. Afterwards, the release circuits of the SR22 ... ESC close. Signal sequence monitoring is only active if wired for automatic start. The EDM signal must be applied for max. 20 ms at S12 after the signal is received.

- **Monitoring of the S inputs**

In the event of a cross connection at inputs S12 and S22 or of a short circuit of input S12 to ground, output relays K1 and K2 are switched off via an electronic fuse. The SR22...ESC is again ready for operation approximate 2 s after the cause of the malfunction has been eliminated.

- **Start button monitoring during manual start (see figure 1), (see figure 2), (see figure 3)**

To detect static faults or blocking of the start button, the button function is monitored for signal changes. Enabling occurs when the button is released (1/0 signal change). During automatic start (see e.g. figures 4, 5), this function is deactivated.

- **Contactor monitoring (EDM) with manual start (see figure 2)**

For function monitoring of the external contactors, their NC contacts (K4, K5) are looped into start circuit S35 with start button in series.

- **Contactor monitoring (EDM) with automatic start (see figure 4)**

For function monitoring of the external contactors, their NC contacts (K4, K5) are looped in between S34 and S35 in series.