

IO-Link Hub

LKHA-16UP-M12G

----System Manual



1.1 Scope of this manual:

This manual applies to the ELCO IO-Link signal Hub (16-bit M12, Metal housing): LKHA-16UP-M12G.

Product overview:

1) LKHA-16UP-M12G

Supply Voltage 24VDC, self-consumption max.100mA;

8 x Port module for

16 x Digital Input (Input Supply 8 x 24VDC/200mA)

or

16 x Digital Output (8 x 24VDC/500mA, max. in total 2A)

You can see the datasheet in Section 2.1.

This product is specifically designed for industrial use and needs to be applied under specific conditions. This product serves as an IO-Link device and needs to be connected to the IO-Link master for use.

1.2 Basic knowledge requirements

Operators need to have basic knowledge in the fields of electrical and automation engineering. Any improper operation may cause harm to the equipment or human body.

This manual describes each component based on valid data at the time of release, and new components and parameter adjustments will be updated in the new version of the manual.

1.3 Guide:

This manual describes the hardware of IO-Link signal Hub.

Covered topics are:

- Installation and wiring
- Commissioning and diagnostics
- Components
- Article numbers
- Technical specifications

1.4 Technical support:

Please contact your local ELCO representative or call hotline if you have any questions about the products described in this manual.

Additional information about ELCO products is available:

Corporate name: Tianjin Elco Automation Co., Ltd

Company address: No. 12, 4th XEDA Branch Road, Xiqing Economic-Technological Development Area ,Tianjin China

Website: <https://www.elcoautomation.com/en-us/>

1.5 Electrical installation:



WARNING

Danger due to electrical voltage!

An unqualified installation can affect the use of the equipment or lead to equipment damage!

- Only qualified electrical engineering personnel may install the modules.
- Only operate on 24 V DC voltage.
- Must be connected to limited power source (LPS).
- Use Copper Conductors Only. Use min. 22 AWG for IO-Link port connector and min. 26 AWG for Signal I/O connector.

ATTENTION

La tension pose un danger!

Une installation non conforme peut affecter l'utilisation de l'appareil ou causer des dommages à l'appareil!

- Seuls les ingénieurs électriciens qualifiés peuvent installer les modules.
- Fonctionne uniquement à 24 V DC.
- Doit être connecté à une alimentation électrique limitée (LPS).
- Utilisez uniquement des conducteurs en cuivre. Le connecteur de port io - LINK utilise un minimum de 22 AWG et le connecteur d'E / s de signal un minimum de 26 AWG.



ATTENTION

Damages due to open plugs and sockets!

Protection rating IP67 is only guaranteed if all connections are tightly sealed.

- Seal unused plugs and sockets with screw plugs or caps.

1.6 Disclaimer of liability:



- Only qualified personnel may perform installation, commissioning, modification, inspection and retrofitting activities.
- Follow the applicable regulations and standards in the operating instructions and manual.
- Follow the safety regulations of the Employers' Liability Insurance Association and electrical engineering.

If the equipment is used in a manner not specified by the manufacturer, the protection provided by the equipment may be impaired. We assume no liability for product damage or subsequent damage arising from non-observance of the regulations or improper handling of the products.

2.1 Datasheet

LKHA-16UP-M12G

ARTICLE PROPERTIES

PRODUCT TYPE	IO-Link IP67 Hub
DESCRIPTION	16 DI/DO, Class-A, 8*M12

ELECTRICAL CONNECTION

IO-LINK	Class-A: 1 × M12 A-code 4pin, Male	SIGNAL	8 × M12 A-code 5 pin, Female
POWER SUPPLY	Included in IO-Link interface		

ELECTRICAL PARAMETERS

INPUT CHANNELS	Max. 16	OUTPUT CHANNELS	Max. 16
INPUT SUPPLY CURRENT	Max. 200 mA per channel, 1.6 A in total	OUTPUT CURRENT	Max. 500 mA per channel, 2 A in total
INPUT TYPE	PNP sensors, mechanical switches, dry contacts, etc.	OUTPUT TYPE	Lamps, solenoidvalve, etc.
INPUT DELAY	1.6 ms	OUTPUT FREQUENCY	Resistive load 100 Hz, Inductive load 5 Hz
MODULE COMMUNICATION INDICATOR	Green LED	PROCESS DATA IN	8 bytes
POWER SUPPLY INDICATOR	Green LED	PROCESS DATA OUT	2 bytes
SIGNAL STATUS INDICATOR	Green LED		

DIAGNOSTICS

COMMUNICATION STATUS	LED indication, communication message	SHORT-CIRCUIT	Support, LED indication
VOLTAGE DETECTION	Support, low voltage alarm	OVERLOAD	Support, LED indication

FUNCTIONAL SAFETY

MTTF (40 °C)	65a
---------------------	-----

GENERAL DATA

PROTECTION CLASS	IP67	OPERATING TEMPERATURE	-25 ... +70 °C
DIMENSIONS	55 × 145 × 27.5 mm	STORAGE TEMPERATURE	-40 ... +85 °C
WEIGHT	349.3 g	HOUSING MATERIAL	Casting Zinc Alloy

APPROVALS



2.2 LED indicator

IO-Link signal hub indicator

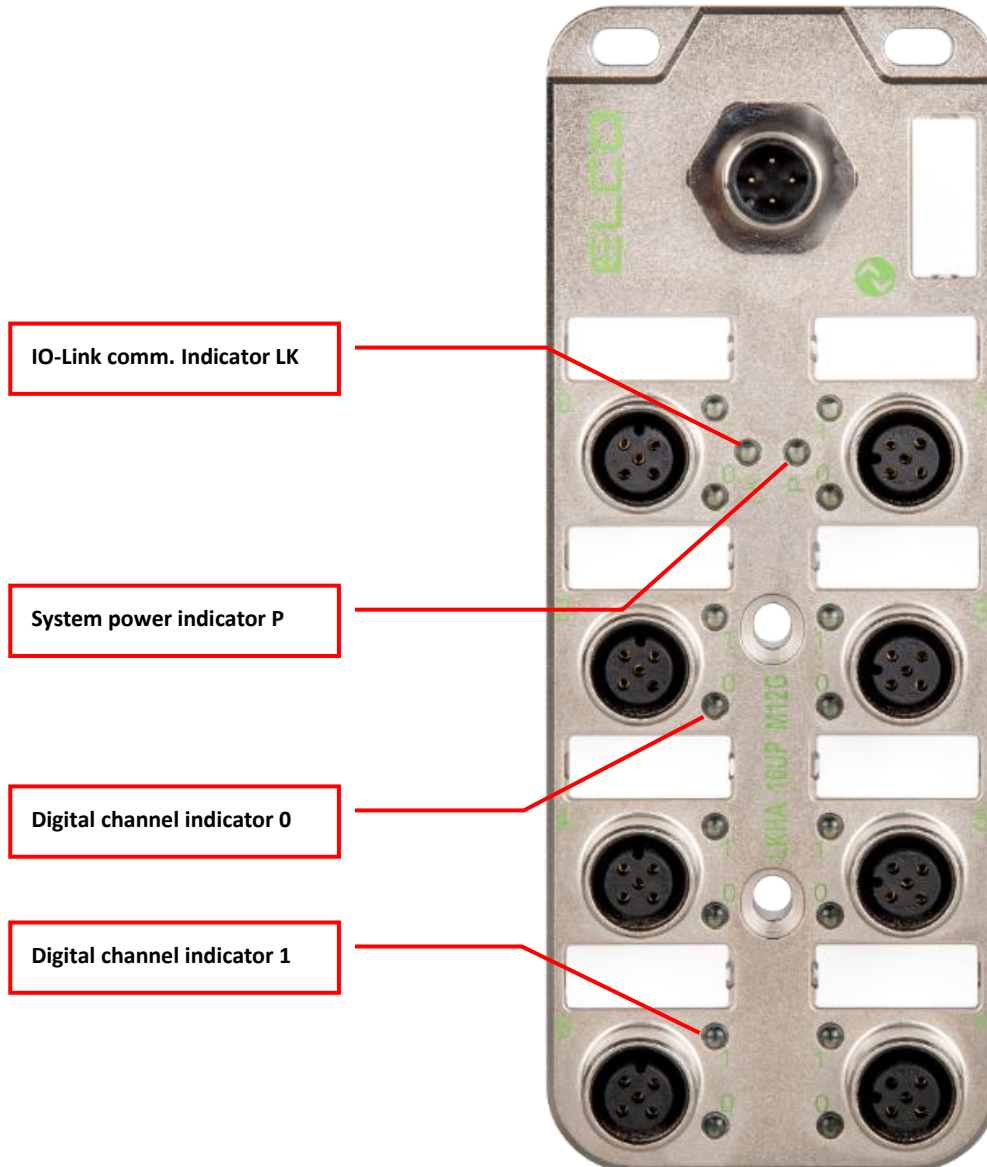

2.3 IO-Link signal hub indicator

Name	Status	Meaning	Fault cause
Module communication Indicator LK	Green flash	Receive IO-Link communication	-
	Off	No IO-Link signal received	1.Expansion cable failure 2.Master IO-Link port problem 3.Slave module is damaged
Module Power supply Indicator P	Red	Ua power fault	1. No Ua enable signal provided 2.Expansion cable failure
	Green	Us and Ua power OK	-
	Off	No power	1.Expansion cable failure 2. Slave module is damaged
Signal / status Indicator	Red	Abnormal signal	1.Signal overload or short circuit 2.Slave module is damaged
	Green	Have signal	-
	Off	No signal	-

2.4 IO-Link signal hub dimensions

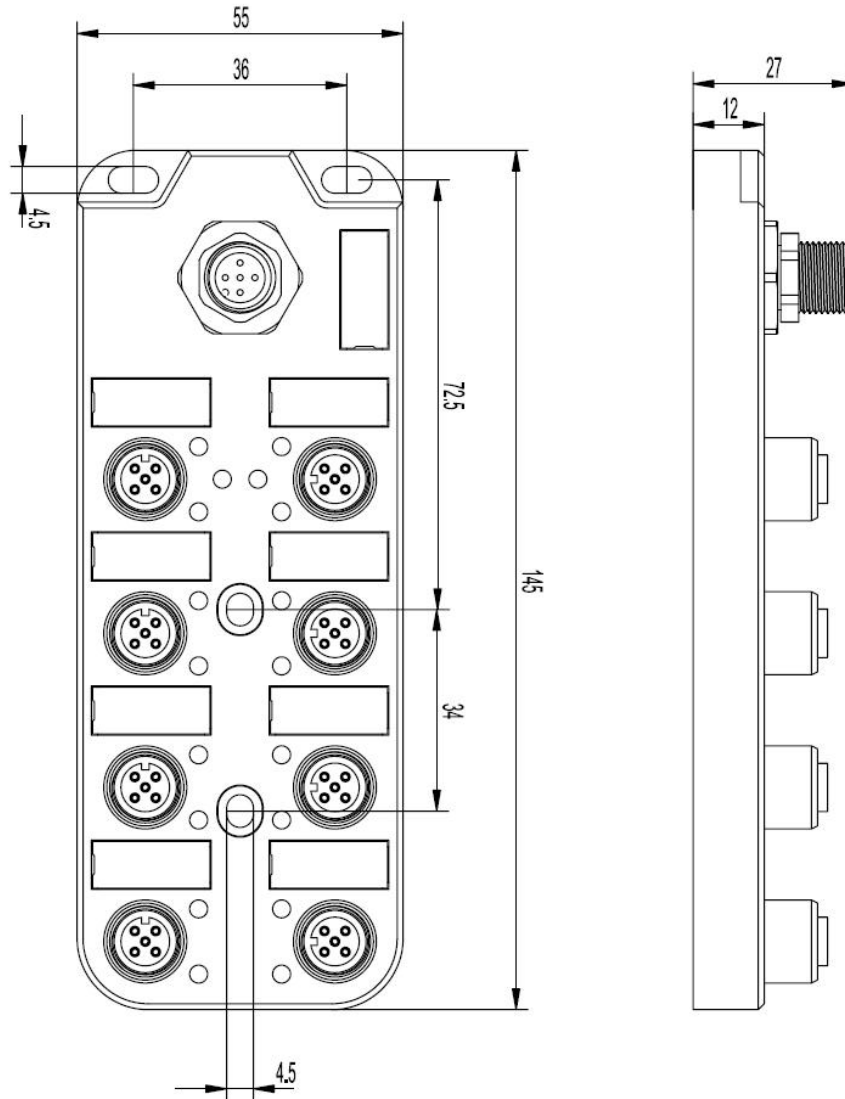

2.5 Mounting the module

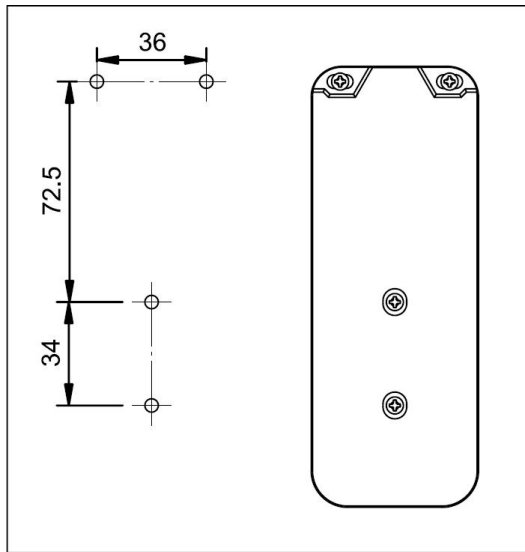

Dimensions in mm

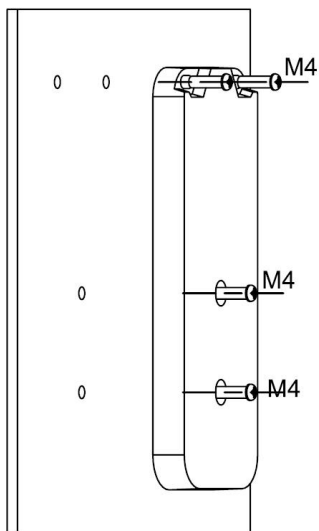

Use screws that are suitable for the mounting surface structure.

3.1 Wiring

Please make sure to cut off power supply when wiring to ensure safety.

- 1) IO-Link port connector (M12 A-Code 4-pin, Male)

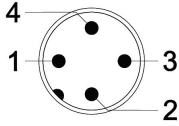

Terminal	Class-A
1	Power supply 24V+ (Us)
2	Power supply P24 (Ua)
3	Power supply GND
4	IO-Link C/Q

- 2) Signal I/O connector (M12 A-Code 5-pin, Female)

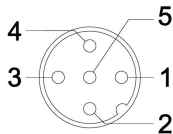

Terminal	M12 connector	
1	Power supply 24V+	
2	Signal input/output 1	2 nd signal
3	Power supply GND	
4	Signal input/output 0	1 st signal
5	Function grounding FE	

- 3) Wiring example

- A) Double PNP input signal – 1 connector connects 2 DI, LKHA-16UP-M12G support this connection.

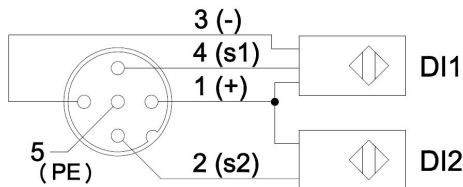

- B) Double PNP output signal – 1 connector connects 2 DO, LKHA-16UP-M12G support this connection.

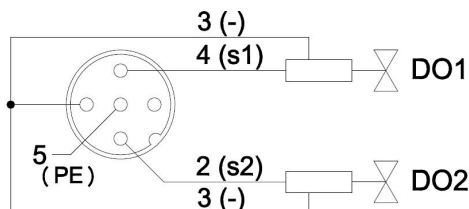

C) PNP Input and output signal – 1 connector connects 1 DI and 1 DO. LKHA-16UP-M12G support this connection.

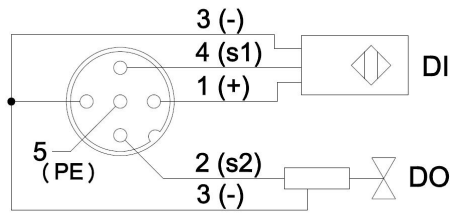

3.2 Signal address assignment

The LKHA-16UP-M12G module is allocated 8 Byte Inputs and 2 Byte Outputs. Users can read the signal input and diagnostic status of the module through these datas, and control the signal output.

1) Process Data INPUT Mapping

A total of 8 bytes (Bytes 0-7) of input data are occupied.

INPUT	Description
Byte 0	Input signal data of Port 0~3
Byte 1	Input signal data of Port 4~7
Byte 2	Short Circuit Diagnosis of Port 0~7
Byte 3	Power Supply Diagnosis
Byte 4	Overload Diagnosis of Port 0~3
Byte 5	Overload Diagnosis of Port 4~7
Byte 6	Ouptut warning of Port 0~3
Byte 7	Ouptut warning of Port 4~7

For a detailed description of the INPUT, please refer to the following text:

Byte 0~1 (Input signal data of Port 0~7)

This section consists of 2 Bytes, used to represent the state when the signal port is connected to a switch signal.

Byte 0	Digital input status of port 0~3							
Bit	Bit_7	Bit_6	Bit_5	Bit_4	Bit_3	Bit_2	Bit_1	Bit_0
No.	3-1	3-0	2-1	2-0	1-1	1-0	0-1	0-0
Pin	Port3 Pin2	Port3 Pin4	Port2 Pin2	Port2 Pin4	Port1 Pin2	Port1 Pin4	Port0 Pin2	Port0 Pin4
Byte 1	Digital input status of port 4~7							
Bit	Bit_7	Bit_6	Bit_5	Bit_4	Bit_3	Bit_2	Bit_1	Bit_0
No.	7-1	7-0	6-1	6-0	5-1	5-0	4-1	4-0
Pin	Port7 Pin2	Port7 Pin4	Port6 Pin2	Port6 Pin4	Port5 Pin2	Port5 Pin4	Port4 Pin2	Port4 Pin4

Byte 2 (Short Circuit Diagnosis)

When a short circuit fault occurs between pins Pin1 and Pin3 of the signal port, the corresponding point indicates 1,

We reserve the right to make technical alterations without prior notice. |EN| Creation date: 20.12.25 | UM_AD_LKHA-16UP-M12G_V1.0

otherwise the point indicates 0.

Byte 2	Short Circuit Diagnosis of Port 0~7							
Bit	Bit_7	Bit_6	Bit_5	Bit_4	Bit_3	Bit_2	Bit_1	Bit_0
Port	Port7	Port6	Port5	Port4	Port3	Port2	Port1	Port0

Byte 3 (Power Supply Diagnosis)

When there is an abnormality in the power supply of the module, according to the fault status of overvoltage and undervoltage of the voltage value, the corresponding point indication is 1, otherwise the point is 0.

Byte 3	Power Supply Diagnosis							
Bit	Bit_7	Bit_6	Bit_5	Bit_4	Bit_3	Bit_2	Bit_1	Bit_0
Mean	-	-	-	-	-	Ua_L Low voltage	-	Us_L Low voltage

Byte 4~5 (Overload Diagnosis)

When an overload fault occurs between the signal port pins Pin4/Pin2 and Pin3, the corresponding point indicates 1, otherwise the point indicates 0.

Byte 4	Overload Diagnosis of Port 0~3							
Bit	Bit_7	Bit_6	Bit_5	Bit_4	Bit_3	Bit_2	Bit_1	Bit_0
Pin	Port3 Pin2	Port3 Pin4	Port2 Pin2	Port2 Pin4	Port1 Pin2	Port1 Pin4	Port0 Pin2	Port0 Pin4
Byte 5	Overload Diagnosis of Port 4~7							
Bit	Bit_7	Bit_6	Bit_5	Bit_4	Bit_3	Bit_2	Bit_1	Bit_0
Pin	Port7 Pin2	Port7 Pin4	Port6 Pin2	Port6 Pin4	Port5 Pin2	Port5 Pin4	Port4 Pin2	Port4 Pin4

Byte 6~7 (Output warning)

When the output port is not activated, the PIN of the port reads the input signal or detects voltage being supplied, the corresponding point indicates 1, otherwise the point indicates 0.

Byte 6	Output warning of Port 0~3							
Bit	Bit_7	Bit_6	Bit_5	Bit_4	Bit_3	Bit_2	Bit_1	Bit_0
Pin	Port3	Port3	Port2	Port2	Port1	Port1	Port0	Port0

	Pin2	Pin4	Pin2	Pin4	Pin2	Pin4	Pin2	Pin4
Byte 7	Output warning of Port 4~7							
Bit	Bit_7	Bit_6	Bit_5	Bit_4	Bit_3	Bit_2	Bit_1	Bit_0
Pin	Port7 Pin2	Port7 Pin4	Port6 Pin2	Port6 Pin4	Port5 Pin2	Port5 Pin4	Port4 Pin2	Port4 Pin4

2) Process Data OUTPUT Mapping

A total of 2 bytes (Bytes 0-1) of output data are occupied.

INPUT	Description
Byte 0	Output signal data of Port 0~3
Byte 1	Output signal data of Port 4~7

For a detailed description of the OUTPUT, please refer to the following text:

Byte 0~1 (Output signal data of Port 0~7)

This section consists of 2 Bytes, used to represent the output of the signal port control switch signal.

Byte 0	Digital output status of port 0~3							
Bit	Bit_7	Bit_6	Bit_5	Bit_4	Bit_3	Bit_2	Bit_1	Bit_0
No.	3-1	3-0	2-1	2-0	1-1	1-0	0-1	0-0
Pin	Port3 Pin2	Port3 Pin4	Port2 Pin2	Port2 Pin4	Port1 Pin2	Port1 Pin4	Port0 Pin2	Port0 Pin4
Byte 1	Digital output status of port 4~7							
Bit	Bit_7	Bit_6	Bit_5	Bit_4	Bit_3	Bit_2	Bit_1	Bit_0
No.	7-1	7-0	6-1	6-0	5-1	5-0	4-1	4-0
Pin	Port7 Pin2	Port7 Pin4	Port6 Pin2	Port6 Pin4	Port5 Pin2	Port5 Pin4	Port4 Pin2	Port4 Pin4

3.3 ISDU parameter assignment

This section is for the ISDU parameter settings of IO-Link Signal Hub. Users can read and modify the configuration of the module by modifying the corresponding parameter values. Users need to modify these parameters through the IO-Link master and the specific method depends on the connected IO-Link master.

Index	Sub-index	Parameter	Access	Data Length	Default Value
16 (0x10)	0	Vendor Name	R	4 Byte	ELCO
17 (0x11)	0	Vendor text	R	20 Byte	www.elco-holding.com
18 (0x12)	0	Product name	R	14 Byte	LKHA-16UP-M12G
19 (0x13)	0	Product ID	R	8 Byte	FB330076
20 (0x14)	0	Product text	R	18 Byte	IO-Link Signal Hub
21 (0x15)	0	Serial number	R	8 Byte	00000000
22 (0x16)	0	Hardware Rev.	R	8 Byte	HW-V0.01
23 (0x17)	0	Firmware Rev.	R	8 Byte	FW-V0.01
24 (0x18)	0	Application Specific Tag	R	32 Byte	***
64 (0x40)	0 (1-16)	Input Inversion	R/W	2 Byte	0x0000
65 (0x41)	0 (1-16)	Port Direction	R/W	4 Byte	0xFFFFFFFF
66 (0x42)	0 (1-8)	Fault State Pin4	R/W	2 Byte	0x0000
67 (0x43)	0 (1-8)	Fault State Pin2	R/W	2 Byte	0x0000
80 (0x50)	1	Port Layout	R/W	1 Byte	0x01
81 (0x51)	1	Input Delay	R/W	1 Byte	0x04

1) Input Inversion (Index: 0x40)

Set whether the input signal is displayed normally.

“0”- not inverted;

“1”- inverted.

Byte 0	Input Inversion of Pin4							
Bit	Bit_7	Bit_6	Bit_5	Bit_4	Bit_3	Bit_2	Bit_1	Bit_0
Subindex	8	7	6	5	4	3	2	1
Pin	Port7 Pin4	Port6 Pin4	Port5 Pin4	Port4 Pin4	Port3 Pin4	Port2 Pin4	Port1 Pin4	Port0 Pin4
Byte 1	Input Inversion of Pin2							
Bit	Bit_7	Bit_6	Bit_5	Bit_4	Bit_3	Bit_2	Bit_1	Bit_0
Subindex	16	15	14	13	12	11	10	9
Pin	Port7 Pin2	Port6 Pin2	Port5 Pin2	Port4 Pin2	Port3 Pin2	Port2 Pin2	Port1 Pin2	Port0 Pin2

2) Port Direction (Index: 0x41)

Set the signal direction of Pin4 & Pin2 for each port.

“0”- Input;

“1”- Output;

“3”- I/O Universal.

Byte 0								
Port Direction of Pin4 of Port 0~3								
Bit	Bit_7	Bit_6	Bit_5	Bit_4	Bit_3	Bit_2	Bit_1	Bit_0
Subindex	4		3		2		1	
Pin	Port3 Pin4		Port2 Pin4		Port1 Pin4		Port0 Pin4	
Byte1								
Port Direction of Pin4 of Port 4~7								
Bit	Bit_7	Bit_6	Bit_5	Bit_4	Bit_3	Bit_2	Bit_1	Bit_0
Subindex	8		7		6		5	
Pin	Port7 Pin4		Port6 Pin4		Port5 Pin4		Port4 Pin4	
Byte 2								
Port Direction of Pin2 of Port 0~3								
Bit	Bit_7	Bit_6	Bit_5	Bit_4	Bit_3	Bit_2	Bit_1	Bit_0
Subindex	12		11		10		9	
Pin	Port3 Pin2		Port2 Pin2		Port1 Pin2		Port0 Pin2	
Byte 3								
Port Direction of Pin2 of Port 4~7								
Bit	Bit_7	Bit_6	Bit_5	Bit_4	Bit_3	Bit_2	Bit_1	Bit_0
Subindex	16		15		14		13	
Pin	Port7 Pin2		Port6 Pin2		Port5 Pin2		Port4 Pin2	

3) Fault State Pin4 (Index: 0x42)

Set the safety status of Pin4 output when communication fault occurs.

“0”- Set to 0;

“1”- Set to 1;

“2”- Hold last value.

Byte 0								
Fault State Pin4 of Port 0~3								
Bit	Bit_7	Bit_6	Bit_5	Bit_4	Bit_3	Bit_2	Bit_1	Bit_0
Subindex	4		3		2		1	

Pin	Port3 Pin4		Port2 Pin4		Port1 Pin4		Port0 Pin4	
Byte1	Fault State Pin4 of Port 4~7							
Bit	Bit_7	Bit_6	Bit_5	Bit_4	Bit_3	Bit_2	Bit_1	Bit_0
Subindex	8		7		6		5	
Pin	Port7 Pin4		Port6 Pin4		Port5 Pin4		Port4 Pin4	

4) Fault State Pin2 (Index: 0x43)

Set the safety status of Pin2 output when communication fault occurs.

“0”- Set to 0;

“1”- Set to 1;

“2”- Hold last value.

Byte 0	Fault State Pin2 of Port 0~3							
Bit	Bit_7	Bit_6	Bit_5	Bit_4	Bit_3	Bit_2	Bit_1	Bit_0
Subindex	4		3		2		1	
Pin	Port3 Pin2		Port2 Pin2		Port1 Pin2		Port0 Pin2	
Byte1	Fault State Pin2 of Port 4~7							
Bit	Bit_7	Bit_6	Bit_5	Bit_4	Bit_3	Bit_2	Bit_1	Bit_0
Subindex	8		7		6		5	
Pin	Port7 Pin2		Port6 Pin2		Port5 Pin2		Port4 Pin2	

4) Fault State Pin2 (Index: 0x43)

Set the safety status of Pin2 output when communication fault occurs.

“0”- Set to 0;

“1”- Set to 1;

“2”- Hold last value.

Byte 0	Fault State Pin2 of Port 0~3							
Bit	Bit_7	Bit_6	Bit_5	Bit_4	Bit_3	Bit_2	Bit_1	Bit_0
Subindex	4		3		2		1	
Pin	Port3 Pin2		Port2 Pin2		Port1 Pin2		Port0 Pin2	

Byte1	Fault State Pin2 of Port 4~7							
Bit	Bit_7	Bit_6	Bit_5	Bit_4	Bit_3	Bit_2	Bit_1	Bit_0
Subindex	8		7		6		5	
Pin	Port7 Pin2		Port6 Pin2		Port5 Pin2		Port4 Pin2	

5) Port Layout (Index: 0x50)

Set the address mapping order of the hub's switch input and output signals.

"1"- Port base (arranged by Port sequence);

"2"- Pin base (arranged by Pin4 and then Pin2).

Byte 0	Port Layout							
Bit	Bit_7	Bit_6	Bit_5	Bit_4	Bit_3	Bit_2	Bit_1	Bit_0
Subindex							1	
Layout							Value	

6) Input Delay (Index: 0x51)

Set the filter time of the input signals. This time means that the signal needs to continuously exceed the set value in order to be detected

"0"- 0ms; "3"- 0.8ms; "4"- 1.6ms; "5"- 3.2ms; "7"- 20ms;

Byte 0	Input Delay							
Bit	Bit_7	Bit_6	Bit_5	Bit_4	Bit_3	Bit_2	Bit_1	Bit_0
Subindex							1	
Delay							Value	