

FX20 series Modular I/O System ModbusTCP User Manual



Content

1. Product introduction.....	3
2. Version change record	3
3. About obtaining manuals.....	3
4. Warranty statement	3
5. Precautions	3
5.1. Safety statement.....	4
5.2. Definition of safety level	4
5.3. Safety and tips.....	4
6. FX20 Product Introduction.....	7
6.1. Appearance and function of ModbusTCP bus adapter.....	7
6.2. FX20 ModbusTCP adapter technical data	8
6.3. FX20 adapter profile drawing.....	9
6.4. Introduction to the appearance of I/O modules.....	9
6.4.1. 8-channel digital input/output module	9
6.4.2. 16-channel digital input output module.....	18
6.4.3. 32-channel digital input output module.....	23
6.4.4. 4-channel analog input/output module	28
6.4.5. 8-channel analog input output modules	32
6.4.6. 4-channel temperature measurement modules.....	37
6.4.7. Auxiliary power module.....	40
7. Mechanical installation and disassembly	43
7.1. Installation location and minimum installation distance.....	43
7.2. FX20 adapter installation	43
7.3. I/O modules installation.....	43
7.4. Modules disassembly.....	44
8. Electrical installation and wiring.....	46
8.1. Cable specification	46
8.1.1. Communication cable	46
8.1.2. Power and signal cables.....	46
8.2. Modules wiring diagram	48
8.2.1. FX20 system power supply diagram	48
8.2.2. Bus adapters wiring diagram	49
8.2.3. ModbusTCP bus adapters wiring diagram	49
8.2.4. 8-channel DI module wiring diagram and I/O mapping	49
8.2.5. 8-channel DO PNP module wiring diagram and I/O mapping.....	50
8.2.6. 8-channel DO NPN module wiring diagram and I/O mapping.....	50
8.2.7. 4-channel SSR (AC) output module wiring diagram I/O mapping	51
8.2.8. 8-channel relay output module wiring diagram and I/O mapping.....	51
8.2.9. 16-channel DI module wiring diagram and I/O mapping	52
8.2.10. 16-channel DO PNP module wiring diagram and I/O mapping.....	52

- 8.2.11. 16-channel DO NPN module wiring diagram and I/O mapping..... 53
- 8.2.12. 32-channel DI module wiring diagram and I/O mapping 54
- 8.2.13. 32-channel DO PNP module wiring diagram and I/O mapping 55
- 8.2.14. 32-channel DO NPN module wiring diagram and I/O mapping..... 56
- 8.2.15. 4-channel AI module wiring diagram and I/O mapping..... 57
- 8.2.16. 4-channel AO module wiring diagram and I/O mapping..... 57
- 8.2.17. 8-channel AI module wiring diagram and I/O mapping..... 58
- 8.2.18. 8-channel AO module wiring diagram and I/O mapping..... 59
- 8.2.19. 4-channel RTD module wiring diagram and I/O mapping 59
- 8.2.20. 4-channel TC module wiring diagram and I/O mapping..... 60
- 8.2.21. Auxiliary power module wiring diagram..... 61
- 9. Configuration and test 62
 - 9.1. IP address setting for ModbusTCP adapter..... 62
 - 9.1.1. Set the IP address through the rotary switches..... 62
 - 9.1.2. Set IP address using FX20 web server 62
 - 9.1.3. Reset IP address 63
 - 9.2. ModbusTCP Operation Instructions..... 63
 - 9.2.1. Function code..... 63
 - 9.2.2. Module data reading..... 64
 - 9.2.3. Error Code Query 65
 - 9.2.4. Module type query 65
 - 9.3. Configuration Test Example 66
 - 9.3.1. Perform module function testing on FX20 using MODBUS debugging assistant ... 66
 - 9.3.2. Configure module parameters through web server 70
 - 9.4. Representation of analog module values 74
 - 9.4.1. Analog value input and output range of bipolar current..... 74
 - 9.4.2. Analog value input and output range of bipolar voltage..... 74
 - 9.4.3. Analog value input and output range of unipolar current 75
 - 9.4.4. Analog value input and output range of unipolar voltage..... 75
 - 9.4.5. Analog value representation within the measurement range of PT x00 standard thermal resistance 76
 - 9.4.6. Representation of simulated values within the measurement range of thermocouples.. 76
- 10. Fault diagnosis 77

1. Product introduction

The FX20 series modular I/O system is a new generation IP20 expandable I/O product launched by Elco. It's composed of bus adapters, I/O modules and functional modules, with the min. module width of only 15 mm, which is thin and compact, greatly saving space inside the control cabinet. The wiring terminal is designed with two separate sections, which facilitates module replacement and maintenance. Keeping the fresh family color scheme, it provides practical tool-free spring terminals for fast and convenient wiring. The terminal buttons are identified by color, and different colors represent different functions, improving the efficiency of wiring and checking to the most.

FX20 adopts high-speed backplane bus technology, with high communication bandwidth and fast response speed, which can meet the application of high-speed production takt. By simply replacing the bus coupler, different automation bus systems can be connected. Currently, it is mainly compatible with mainstream Ethernet bus protocols such as EtherCAT, PROFINET, EtherNet/IP, CC-Link IE Field Basic, and can expand up to 32 sub-modules.

FX20 has a wide range of sub-modules with powerful functions, including digital input and output, relay output, analog input and output, temperature measurement, high-speed counting, IO-Link master, serial communication, etc. It can meet the needs of various automation systems and is widely used in industries such as automobile manufacturing, parts processing, 3C electronics, lithium battery equipment, photovoltaic, logistics, printing and packaging.

This manual mainly introduces the mechanical installation, electrical installation, and module configuration examples of FX20 products.

2. Version change record

Revision date	Version	Content changed
2023-8	V1.0	1st version
2025-2	V1.1	Content updates
2025-6	V1.2	Images and layout updates
2025-12	V2.0	Update fonts and layouts

3. About obtaining manuals

This manual is not shipped with the product. You can obtain its PDF file through the following methods:

- Log in to Elco's official website (www.elcoautomation.com), search for keywords, and download.
- Use WeChat to search and subscribe the official account of "Elco Automation" to obtain the product manual.
- Contact Elco sales engineers in your area to obtain the latest manual materials.

4. Warranty statement

Under normal use, if the product malfunctions or is damaged, Elco will be responsible for an 18 months warranty (from and subject to the delivery date; executed according to the agreement, if there is a contract). When it's over 18 months, maintenance fees will be charged.

- Within 18 months, repair fees will be charged for product damaged by the following circumstances.
- Failure to operate according to the manual
- Fires, floods, and abnormal voltage
- Used for abnormal functions
- Beyond the application scope
- Force majeure (natural disasters, earthquakes, lightning strikes).

The service fees shall be calculated according to Elco's unified standards. Subject to the contract, if there is.

5. Precautions

5.1. Safety statement

- 1) Please read and follow these precautions before installing, operating, and maintaining the product.
- 2) To ensure personal and equipment safety, please follow all precautions indicated on the product and in the manual when installing, operating, and maintaining the product.
- 3) The 'caution', 'warning' and 'danger' items in the manual do not represent all precautions that should be followed, but only serve as supplements to all safety precautions.
- 4) This product should be used in an environment that meets the design specifications, otherwise it may cause malfunctions. Functional abnormalities or component damage caused by non-compliance with relevant regulations are not within the scope of product quality assurance.
- 5) Elco will not bear any legal responsibility for personal safety accidents, property losses, etc. caused by mishandling of products.

5.2. Definition of safety level

Caution	If not operated properly, it may result in minor body injury or equipment damage
Warning	If not operated properly, it may result in death or serious bodily injury.
Danger	If not operated properly, it will result in death or serious bodily injury.

5.3. Safety and tips

	Reminding		Please refer to the relevant manual content before operation
	Risk of electrical shock		Information tips
	General tips		Only authorized electrical personnel can operate
	Earthing		Only authorized mechanical personnel can operate

When designing control systems

Dangerous!

- Please be sure to design a safety circuit to ensure that the control system can still work safely in the event of external power failure or PLC failure;
- When long time overcurrent caused by exceeding rated load current or short circuit, the module may smoke or catch fire. So, safety devices such as fuses or circuit breakers need to be installed.

When installing

Warning!

- Only professional maintenance personnel who have been trained on electrical equipment and have sufficient electrical knowledge can install this product.

Dangerous!

- During the operation, all external power supplies used by the system must be disconnected. If the power supply is not fully disconnected, it may cause electric shock, module failure or malfunction.
- Do not use programmable controller in the following conditions: places with dust, oil fumes, conductive dust,

corrosive gases, and flammable gas.

- Exposed to high temperatures, condensation, and wind and rain; In situations with vibration and impact. Electric shock, fire, and mis-operation can also cause product damage and deterioration.
- The programmable controller is an Open type device, please install it in a control cabinet with a lock (the IP rating of the control cabinet housing > IP20). Only operators who have been trained on electrical equipment and have sufficient electrical knowledge can open the control cabinet.
- During installation, avoid metal shavings and wire ends falling into the ventilation hole of the controller, which may cause fire, malfunction, and mis-operation.

Caution!

- After installation, ensure that there are no foreign objects on the ventilation surface, otherwise it may cause poor heat dissipation, fire, malfunction, and mis-operation.
- When installing, it needs to be tightly connected to connectors and the module connection hooks need to be securely locked. If the module is installed improperly, it may cause mis-operation, malfunction, and detachment.

When wiring

Dangerous!

- Only professional maintenance personnel who have been trained on electrical equipment and have sufficient electrical knowledge can carry out the wiring of this product;
- During the operation, all external power supplies used by the system must be disconnected. If the power supply is not fully disconnected, it may cause electric shock, module failure or malfunction.

Dangerous!

- Cable terminals should be well insulated to ensure that the insulation distance between cables does not decrease after installation on the terminal block. Otherwise, it may cause electric shock or equipment damage.
- To avoid electric shock, please cut off the power supply before connecting to the power supply of this product;
- The input power specifications of this product can be found in technical specifications. Please provide the power supply strictly in accordance with the data in the technical specifications. If the power supply is not within the required range, it will seriously damage this product. Therefore, please regularly check whether the DC power supply provided by the switching power supply is stable.

During operation and maintenance

Caution!

- Only professional maintenance personnel who have been trained on electrical equipment and have sufficient electrical knowledge can carry out the maintenance.
- Do not touch the terminals when powered on, otherwise it may cause electric shock or malfunction.
- During the operation, all external power supplies used by the system must be disconnected. If the power supply is not fully disconnected, it may cause electric shock or malfunction.
- At locations where operators directly come into contact with mechanical parts, such as loading and unloading mechanical tools, or where machinery operates automatically, careful consideration must be given to the function of on-site manual devices or other backup means. It needs to be independent of programmable controllers and can

start or interrupt the automatic operation of the system.

- If the program needs to be modified while the system is running, it is necessary to consider using locks or other protective measures to ensure that only authorized personnel can make necessary modifications.

When Scrapping

Caution!

- Please treat it as industrial waste;
- Scrapped equipment and products need to be disposed of and recycled according to industrial waste treatment standards to avoid environmental pollution.

Please keep the content of this safety precautions properly for future reference, and be sure to hand over this manual to the end user.

6. FX20 Product Introduction

6.1. Appearance and function of ModbusTCP bus adapter



Item	Name	Function	Status
1	Rail locking device	Lock bus adapter module	Assembling completed: locking position Disassembling module: unlocking position
2	X1	Bus in	-
3	X2	Bus out	-
4	Module fixing device	Fixing module and rail	Disassembling module: pull out Assembling completed: press down
5	Running indicators		
	PWR	Indicate power supply	Green: normal Off: abnormal
	BF	Indicate bus status	Green: normal Red: configuration error
	SF	Report system error	Green: normal Red: Sub-modules error
	STA	Backplane communication status	Green: normal Red: Backplane communication error
6	Power input terminal 0 V	0 V access	-
7	Power input terminal 24 V+	24 V DC access	-
8	PE	System grounding	-
9	Rotary switches	Set IP address	-

6.2. FX20 ModbusTCP adapter technical data

FX20-GW-MT00

ARTICLE PROPERTIES

PRODUCT TYPE	FX20 series modular I/O system ModbusTCP adapter	PRODUCT GROUP	IP20 modular I/O system
DESCRIPTION	Gateway module for ModbusTCP, 2 x RJ45, max. 32 cascadable modules, 24 V DC, IP20, DIN rail installation, overcurrent / reverse polarity / surge protection	PU	1 pcs
		COUNTRY OF ORIGIN	CN

TECHNICAL DATA

COMMUNICATION PROTOCOL	ModbusTCP	SUPPLY VOLTAGE (SYSTEM)	24 V DC (± 20 %)
TRANSMISSION MEDIUM	Twisted pair S-UTP, 100 Ω, Cat. 5	INPUT CURRENT (TYP.) AT NOMINAL LOAD (24 V)	200 mA
TRANSMISSION RATE	10/100 M bit/s	BACKPLANE POWER SUPPLY VOLTAGE	5 V DC
BUS SEGMENT LENGTH (MAX.)	100 m	BACKPLANE POWER SUPPLY CURRENT (MAX.)	3 A
BUS NODE ADDRESS RANGE	1 ... 254 (Rotary code switches setting) or set by configuration software	ELECTRICAL ISOLATION	500 V (power supply and bus)
WEB SERVER	The access address is set according to the rotary code switch or configuration software	POWER PROTECTION	Overcurrent protection, reverse polarity protection, surge protection
MAX. NUMBER OF CASCADABLE MODULES	32	PARAMETERS CONFIGURATION METHOD	Configured by PLC, configure through web server
INPUT AND OUTPUT PROCESS MAPPING (MAX.)	512 bytes / 512 bytes	FAULT DIAGNOSIS METHOD	LED, communication message

CONNECTION DATA

WIRE CONNECTION	Plug-in terminal blocks	STRIPPED LENGTHS	8 ... 10 mm 0.315 ... 0.394 in
CROSS SECTION	0.08 mm ² ... 2.5 mm ² AWG 28 ... 14		

ENVIRONMENTAL REQUIREMENTS

PROTECTION CLASS	IP20	ELECTRICAL FAST TRANSIENT (EFT)	Level A, per IEC 61000-4-4
MOUNTING TYPE	DIN-35 mm rail	ELECTRO-STATIC DISCHARGE (ESD)	Level A, per IEC 61000-4-2
AMBIENT TEMPERATURE	-5 ... +60 °C	SURGE TEST	Level A, per IEC 61000-4-5
STORAGE TEMPERATURE	-25 ... +70 °C	VIBRATION RESISTANCE	4 g, per IEC 60068-2-6
RELATIVE HUMIDITY	95%, non-condensing	SHOCK RESISTANCE	15 g, per IEC 60068-2-27
OPERATING ALTITUDE	0 ... 2000 m / 0 ... 6562 ft	EU ROHS COMPLIANCE STATUS	Yes
POLLUTION DEGREE	2, per IEC 61131-2	MATERIAL COMPLIANCE	Compliant with REACH

GENERAL DATA

HOUSING MATERIAL	PPE	DIMENSIONS (H X W X D)	110.4 x 57 x 78.5 mm
WEIGHT	230 g	MTTF (25 °C)	111 years
COLOR	Light gray	APPROVALS	CE

6.3. FX20 adapter profile drawing

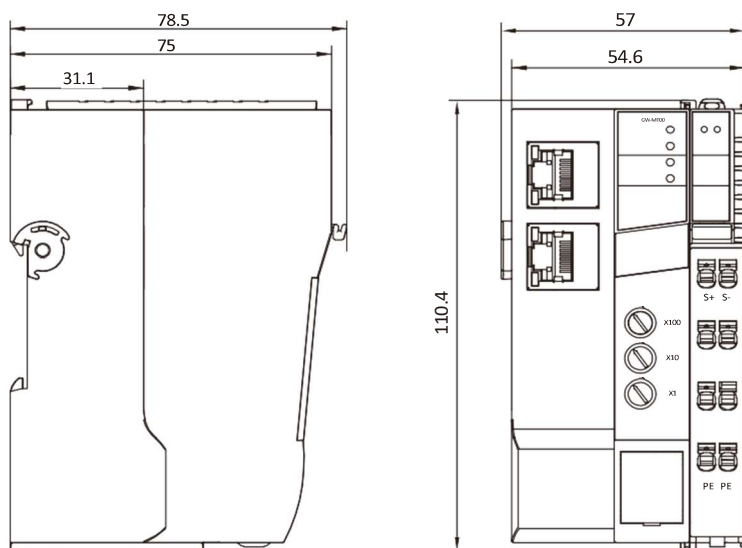

6.4. Introduction to the appearance of I/O modules

6.4.1. 8-channel digital input/output module

6.4.1.1. 8-channel digital input module

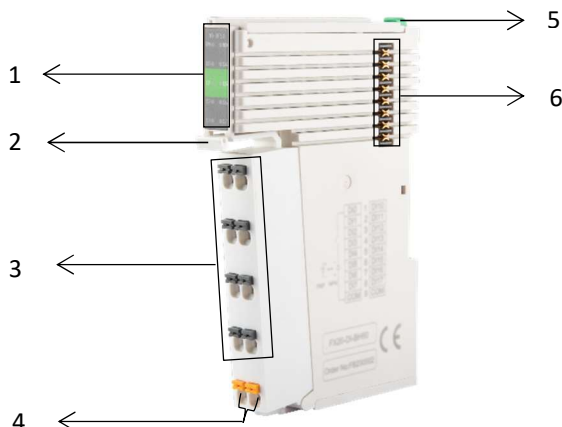

Item	Name	Function	Status
1	Module running indicators		
	PW	Backplane power indicator	Green: normal; Red: I/O power supply abnormal; Off: no backplane power
	MD	Module error indicator	Green: normal Red: Module channel error Green blinking: Connected but not configured; Red and green blinking: Backplane communication abnormal;
	00-07	Input signal indicator	Green: input "1" Off: input "0"
2	Terminal disassembly device	Press the device to separate the terminal block from the module	-
3	IO input terminal 0-7	IO signal wiring	-
4	Common ground terminal	IO signal Common ground terminal	0 V when the input signal is PNP, 24 V+ when the input signal is NPN
5	Module fixing device	Used to fix the module to the standard mounting rail	Pulling up: assembling position; Pressing down: locking position
6	Backplane bus interface	Backplane communication among modules	-

6.4.1.2. 8-channel digital input module technical data

FX20-DI-BF60

ARTICLE PROPERTIES

PRODUCT TYPE	FX20 series modular I/O system digital input modules	PRODUCT GROUP	IP20 modular I/O system
DESCRIPTION	FX20-submodule 8-channel input PNP / NPN, 24 V DC, IP20, DIN rail installation	PU	1 pc
		COUNTRY OF ORIGIN	CN

TECHNICAL DATA

NUMBER OF DIGITAL INPUTS	8	INPUT FILTERING DELAY	0 ms, 1 ms, 3 ms and 10 ms can be configured
INPUT TYPE	PNP / NPN	CURRENT CONSUMPTION (5 V)	60 mA
INPUT SIGNAL '0'	0 ... 5 V DC	PROCESS DATA LENGTH	1 byte
INPUT SIGNAL '1'	18 ... 30 V DC	FAULT DIAGNOSIS METHOD	LED, communication message

INPUT CURRENT PER CHANNEL FOR SIGNAL '1' Typ. 4 mA

CONNECTION DATA

WIRE CONNECTION	Plug-in terminal block	STRIPPED LENGTHS	8 ... 10 mm 0.315 ... 0.394 in
CROSS SECTION	0.08 mm ² ... 2.5 mm ² AWG 28 ... 14		

ENVIRONMENTAL REQUIREMENTS

PROTECTION CLASS	IP20	ELECTRICAL FAST TRANSIENT (EFT)	Level A, per IEC 61000-4-4
MOUNTING TYPE	DIN-35 mm rail	ELECTRO-STATIC DISCHARGE (ESD)	Level A, per IEC 61000-4-2
AMBIENT TEMPERATURE	-5 ... +60 °C	SURGE TEST	Level A, per IEC 61000-4-5
STORAGE TEMPERATURE	-25 ... +70 °C	VIBRATION RESISTANCE	4 g, per IEC 60068-2-6
RELATIVE HUMIDITY	95%, non-condensing	SHOCK RESISTANCE	15 g, per IEC 60068-2-27
OPERATING ALTITUDE	0 ... 2000 m / 0 ... 6562 ft	EU ROHS COMPLIANCE STATUS	Yes
POLLUTION DEGREE	2, per IEC 61131-2	MATERIAL COMPLIANCE	Compliant with REACH

GENERAL DATA

HOUSING MATERIAL	PPE	DIMENSIONS (H X W X D)	110.6 x 15 x 78.4 mm
WEIGHT	63 g	MTTF (25 °C)	155 years
COLOR	Light gray	APPROVALS	CE

6.4.1.3. 8-channel digital output modules

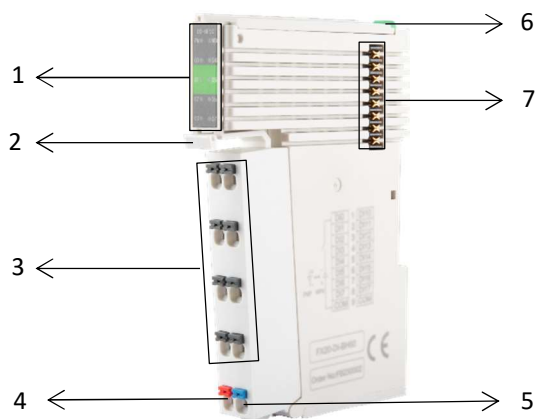

Item	Name	Function	Status
1	Module running indicators		
	PW	Backplane power indicator	Green: normal; Red: I/O power supply abnormal; Off: no backplane power
	MD	Module error indicator	Green: normal Red: Module channel error

			Green blinking: Connected but not configured; Red and green blinking: Backplane communication abnormal;
	00-07	Output signal indicator	Green: output "1" Off: output "0"
2	Terminal disassembly device	Press the device to separate the terminal block from the module	-
3	IO output terminal 0-7	IO signal wiring	-
4	24 V power terminal	24 V+	-
5	24 V power terminal	0 V	-
6	Module fixing device	Used to fix the module to the standard mounting rail	Pulling up: assembling position; Pressing down: locking position.
7	Backplane bus interface	Backplane communication	-

6.4.1.4. 8-channel digital output module technical data

FX20-DO-BF00

ARTICLE PROPERTIES

PRODUCT TYPE	FX20 series modular I/O system digital output modules	PRODUCT GROUP	IP20 modular I/O system
DESCRIPTION	FX20-submodule 8-channel output PNP, 24 V DC, 0.5 A, IP20, DIN rail installation	PU	1 pc
		COUNTRY OF ORIGIN	CN

TECHNICAL DATA

NUMBER OF DIGITAL OUTPUTS	8	SWITCHING FREQUENCY	Max. 1 kHz (Resistive loads) Max. 1 Hz (Inductive loads) Max. 10 Hz (Lamps)
OUTPUT TYPE	PNP	OUTPUT HOLD	Supports, configured by PLC or web server
OUTPUT VOLTAGE	24 V DC	CURRENT CONSUMPTION (5 V)	60 mA
OUTPUT CURRENT	Max. 0.5 A per channel, total 4 A per module	PROCESS DATA LENGTH	1 byte
OUTPUT LOAD TYPES	Resistive loads, inductive loads, lamps	FAULT DIAGNOSIS METHOD	LED, communication message

CONNECTION DATA

WIRE CONNECTION	Plug-in terminal block	STRIPPED LENGTHS	8 ... 10 mm 0.315 ... 0.394 in
CROSS SECTION	0.08 mm ² ... 2.5 mm ² AWG 28 ... 14		

ENVIRONMENTAL REQUIREMENTS

PROTECTION CLASS	IP20	ELECTRICAL FAST TRANSIENT (EFT)	Level A, per IEC 61000-4-4
MOUNTING TYPE	DIN-35 mm rail	ELECTRO-STATIC DISCHARGE (ESD)	Level A, per IEC 61000-4-2
AMBIENT TEMPERATURE	-5 ... +60 °C	SURGE TEST	Level A, per IEC 61000-4-5
STORAGE TEMPERATURE	-25 ... +70 °C	VIBRATION RESISTANCE	4 g, per IEC 60068-2-6
RELATIVE HUMIDITY	95%, non-condensing	SHOCK RESISTANCE	15 g, per IEC 60068-2-27
OPERATING ALTITUDE	0 ... 2000 m / 0 ... 6562 ft	EU ROHS COMPLIANCE STATUS	Yes
POLLUTION DEGREE	2, per IEC 61131-2	MATERIAL COMPLIANCE	Compliant with REACH

GENERAL DATA

HOUSING MATERIAL	PPE	DIMENSIONS (H X W X D)	110.6 x 15 x 78.4 mm
WEIGHT	63 g	MTTF (25 °C)	155 years
COLOR	Light gray	APPROVALS	CE

FX20-DO-BF50

ARTICLE PROPERTIES

PRODUCT TYPE	FX20 series modular I/O system digital output modules	PRODUCT GROUP	IP20 modular I/O system
DESCRIPTION	FX20-submodule 8-channel output NPN, 24 V DC, 0.5 A, IP20, DIN rail installation	PU	1 pc
		COUNTRY OF ORIGIN	CN

TECHNICAL DATA

NUMBER OF DIGITAL OUTPUTS	8	SWITCHING FREQUENCY	Max. 1 kHz (Resistive loads) Max. 1 Hz (Inductive loads) Max. 10 Hz (Lamps)
OUTPUT TYPE	NPN	OUTPUT HOLD	Supports, configured by PLC or web server
OUTPUT VOLTAGE	24 V DC	CURRENT CONSUMPTION (5 V)	60 mA
OUTPUT CURRENT	Max. 0.5 A per channel, total 4 A per module	PROCESS DATA LENGTH	1 byte
OUTPUT LOAD TYPES	Resistive loads, inductive loads, lamps	FAULT DIAGNOSIS METHOD	LED, communication message

CONNECTION DATA

WIRE CONNECTION	Plug-in terminal block	STRIPPED LENGTHS	8 ... 10 mm 0.315 ... 0.394 in
CROSS SECTION	0.08 mm ² ... 2.5 mm ² AWG 28 ... 14		

ENVIRONMENTAL REQUIREMENTS

PROTECTION CLASS	IP20	ELECTRICAL FAST TRANSIENT (EFT)	Level A, per IEC 61000-4-4
MOUNTING TYPE	DIN-35 mm rail	ELECTRO-STATIC DISCHARGE (ESD)	Level A, per IEC 61000-4-2
AMBIENT TEMPERATURE	-5 ... +60 °C	SURGE TEST	Level A, per IEC 61000-4-5
STORAGE TEMPERATURE	-25 ... +70 °C	VIBRATION RESISTANCE	4 g, per IEC 60068-2-6
RELATIVE HUMIDITY	95%, non-condensing	SHOCK RESISTANCE	15 g, per IEC 60068-2-27
OPERATING ALTITUDE	0 ... 2000 m / 0 ... 6562 ft	EU ROHS COMPLIANCE STATUS	Yes
POLLUTION DEGREE	2, per IEC 61131-2	MATERIAL COMPLIANCE	Compliant with REACH

GENERAL DATA

HOUSING MATERIAL	PPE	DIMENSIONS (H X W X D)	110.6 x 15 x 78.4 mm
WEIGHT	63 g	MTTF (25 °C)	155 years
COLOR	Light gray	APPROVALS	CE

6.4.1.5. 8-channel digital input/output module profile drawing

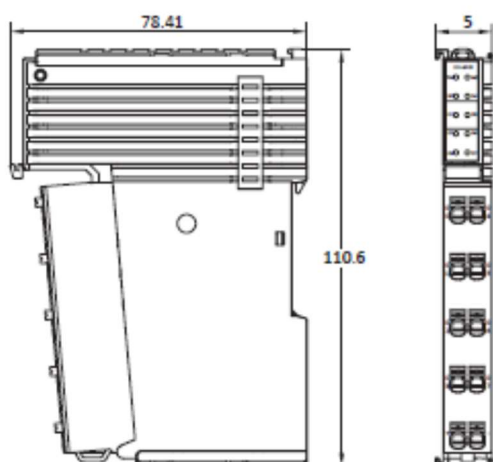

6.4.1.6. 4/8-channel relay output modules

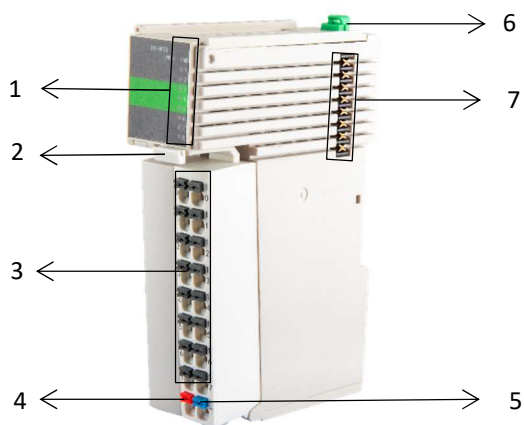

Item	Name	Function	Status
1	Module running indicator		
	PW	Backplane power indicator	Green: normal; Red: I/O power supply abnormal; Off: no backplane power
	MD	Module error indicator	Green: normal Red: Module channel error Green blinking: Connected but not configured; Red and green blinking: Backplane communication abnormal;
	00-07	Output signal indicator	Green: output "1" Off: output "0"
2	Terminal disassembly device	Press the device to separate the terminal block from the module	-
3	IO output terminal 0-7	IO signal wiring	-
4	24 V power terminal	24 V+	-
5	24 V power terminal	0 V	-
6	Module fixing device	Used to fix the module to the standard mounting rail	Pulling up: assembling position; Pressing down: locking position
7	Backplane bus interface	Backplane communication	-

6.4.1.7. 4/8-channel digital relay output modules technical data

FX20-DO-RD00

ARTICLE PROPERTIES

PRODUCT TYPE	FX20 series modular I/O system digital output modules	PRODUCT GROUP	IP20 modular I/O system
DESCRIPTION	FX20-submodule 4-channel output SSR, 230 V AC, IP20, DIN rail installation	PU	1 pc
		COUNTRY OF ORIGIN	CN

TECHNICAL DATA

NUMBER OF DIGITAL OUTPUTS	4	OUTPUT HOLD	Supports, configured by PLC or web server
OUTPUT TYPE	AC solid state relay	RELAY RESPONSE TIME	3 ... 10 ms
CONTACT WORKING VOLTAGE	230 V AC	ELECTRICAL LIFE	20 million times
OUTPUT CURRENT	Max. 0.5 A per channel	CURRENT CONSUMPTION (5 V)	80 mA
OUTPUT LOAD TYPES	Resistive loads, lamps	PROCESS DATA LENGTH	1 byte
SWITCHING FREQUENCY	Max. 0.5 Hz	FAULT DIAGNOSIS METHOD	LED, communication message

CONNECTION DATA

WIRE CONNECTION	Plug-in terminal block	STRIPPED LENGTHS	8 ... 10 mm 0.315 ... 0.394 in
CROSS SECTION	0.08 mm ² ... 2.5 mm ² AWG 28 ... 14		

ENVIRONMENTAL REQUIREMENTS

PROTECTION CLASS	IP20	ELECTRICAL FAST TRANSIENT (EFT)	Level A, per IEC 61000-4-4
MOUNTING TYPE	DIN-35 mm rail	ELECTRO-STATIC DISCHARGE (ESD)	Level A, per IEC 61000-4-2
AMBIENT TEMPERATURE	-5 ... +60 °C	SURGE TEST	Level A, per IEC 61000-4-5
STORAGE TEMPERATURE	-25 ... +70 °C	VIBRATION RESISTANCE	4 g, per IEC 60068-2-6
RELATIVE HUMIDITY	95%, non-condensing	SHOCK RESISTANCE	15 g, per IEC 60068-2-27
OPERATING ALTITUDE	0 ... 2000 m / 0 ... 6562 ft	EU ROHS COMPLIANCE STATUS	Yes
POLLUTION DEGREE	2, per IEC 61131-2	MATERIAL COMPLIANCE	Compliant with REACH

GENERAL DATA

HOUSING MATERIAL	PPE	DIMENSIONS (H X W X D)	110.6 x 28.1 x 78.4 mm
WEIGHT	90 g	MTTF (25 °C)	155 years
COLOR	Light gray	APPROVALS	CE

FX20-DO-RF50

ARTICLE PROPERTIES

PRODUCT TYPE	FX20 series modular I/O system digital output modules	PRODUCT GROUP	IP20 modular I/O system
DESCRIPTION	FX20-submoduel 8-channel output mechanical relays, output voltage 250 V AC / 30 V DC, IP20, DIN rail installation	PU	1 pc
		COUNTRY OF ORIGIN	CN

TECHNICAL DATA

NUMBER OF DIGITAL OUTPUTS	8	OUTPUT HOLD	Supports, configured by PLC or web server
OUTPUT TYPE	Mechanical relays	RELAY RESPONSE TIME	About 15 ms
CONTACT WORKING VOLTAGE	250 V AC / 30 V DC	ELECTRICAL LIFE	100,000 times
OUTPUT CURRENT	Max. 2 A per channel	CURRENT CONSUMPTION (5 V)	65 mA
OUTPUT LOAD TYPES	Resistive loads, lamps	PROCESS DATA LENGTH	1 byte
SWITCHING FREQUENCY	Less than 6 times per minute	FAULT DIAGNOSIS METHOD	LED, communication message

CONNECTION DATA

WIRE CONNECTION	Plug-in terminal block	STRIPPED LENGTHS	8 ... 10 mm 0.315 ... 0.394 in
CROSS SECTION	0.08 mm ² ... 2.5 mm ² AWG 28 ... 14		

ENVIRONMENTAL REQUIREMENTS

PROTECTION CLASS	IP20	ELECTRICAL FAST TRANSIENT (EFT)	Level A, per IEC 61000-4-4
MOUNTING TYPE	DIN-35 mm rail	ELECTRO-STATIC DISCHARGE (ESD)	Level A, per IEC 61000-4-2
AMBIENT TEMPERATURE	-5 ... +60 °C	SURGE TEST	Level A, per IEC 61000-4-5
STORAGE TEMPERATURE	-25 ... +70 °C	VIBRATION RESISTANCE	4 g, per IEC 60068-2-6
RELATIVE HUMIDITY	95%, non-condensing	SHOCK RESISTANCE	15 g, per IEC 60068-2-27
OPERATING ALTITUDE	0 ... 2000 m / 0 ... 6562 ft	EU ROHS COMPLIANCE STATUS	Yes
POLLUTION DEGREE	2, per IEC 61131-2	MATERIAL COMPLIANCE	Compliant with REACH

GENERAL DATA

HOUSING MATERIAL	PPE	DIMENSIONS (H X W X D)	110.6 x 28.1 x 78.4 mm
WEIGHT	90 g	MTTF (25 °C)	155 years
COLOR	Light gray	APPROVALS	CE

6.4.1.8. 4/8-channel digital relay output module profile drawing

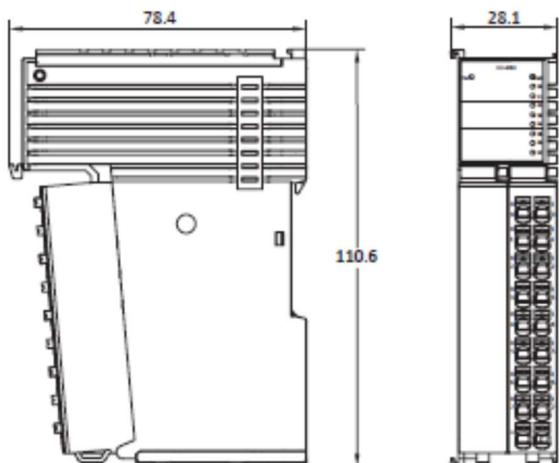

6.4.2. 16-channel digital input output module

6.4.2.1. 16-channel digital input module

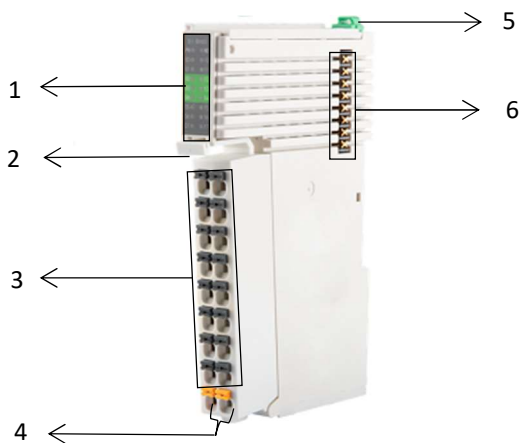

Item	Name	Function	Status
1	Module running indicator		
	PW	Backplane power indicator	Green: normal; Off: no backplane power
	MD	Module error indicator	Green: normal Red: Module channel error Green blinking: Connected but not configured; Red and green blinking: Backplane communication abnormal;
	00-07 10-17	Input signal indicators	Green: output 1 Off: output 0

2	Terminal disassembly device	Press the device to separate the terminal block from the module	-
3	IO input terminal 00-07/10-17	IO signal wiring	-
4	Common terminals	IO signal common terminals	0 V when the input signal is PNP, 24 V+ when the input signal is NPN
5	Module fixing device	Used to fix the module to the standard mounting rail	Pulling up: assembling position; Pressing down: locking position
6	Backplane interface	Backplane communication	-

6.4.2.2. 16 digital input module technical data

FX20-DI-BL60

ARTICLE PROPERTIES

PRODUCT TYPE	FX20 series modular I/O system digital input modules	PRODUCT GROUP	IP20 modular I/O system
DESCRIPTION	FX20-submodule 32-channel input PNP/ NPN, 24 V DC, IP20, DIN rail installation	PU	1 pc
		COUNTRY OF ORIGIN	CN

TECHNICAL DATA

NUMBER OF DIGITAL INPUTS	32	INPUT FILTERING DELAY	0 ms, 1 ms, 3 ms and 10 ms can be configured
INPUT TYPE	PNP / NPN	CURRENT CONSUMPTION (5 V)	60 mA
INPUT SIGNAL '0'	0 ... 5 V DC	PROCESS DATA LENGTH	4 bytes
INPUT SIGNAL '1'	18 ... 30 V DC	FAULT DIAGNOSIS METHOD	LED, communication message
INPUT CURRENT PER CHANNEL FOR SIGNAL '1'	Typ. 4 mA		

CONNECTION DATA

WIRE CONNECTION	Plug-in terminal block	STRIPPED LENGTHS	8 ... 10 mm 0.315 ... 0.394 in
CROSS SECTION	0.08 mm ² ... 2.5 mm ² AWG 28 ... 14		

ENVIRONMENTAL REQUIREMENTS

PROTECTION CLASS	IP20	ELECTRICAL FAST TRANSIENT (EFT)	Level A, per IEC 61000-4-4
MOUNTING TYPE	DIN-35 mm rail	ELECTRO-STATIC DISCHARGE (ESD)	Level A, per IEC 61000-4-2
AMBIENT TEMPERATURE	-5 ... +60 °C	SURGE TEST	Level A, per IEC 61000-4-5

STORAGE TEMPERATURE	-25 ... +70 °C	VIBRATION RESISTANCE	4 g, per IEC 60068-2-6
RELATIVE HUMIDITY	95%, non-condensing	SHOCK RESISTANCE	15 g, per IEC 60068-2-27
OPERATING ALTITUDE	0 ... 2000 m / 0 ... 6562 ft	EU ROHS COMPLIANCE STATUS	Yes
POLLUTION DEGREE	2, per IEC 61131-2	MATERIAL COMPLIANCE	Compliant with REACH

GENERAL DATA

HOUSING MATERIAL	PPE	DIMENSIONS (H X W X D)	110.6 x 28.1 x 78.4 mm
WEIGHT	128 g	MTTF (25 °C)	155 years
COLOR	Light gray	APPROVALS	CE

6.4.2.3. 16-channel digital output module

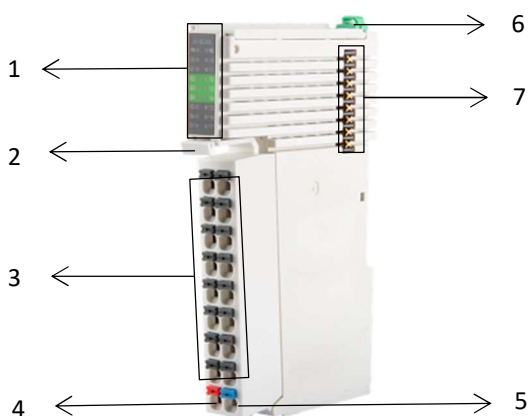

Item	Name	Function	Status
1	Module running indicator		
	PW	Backplane power indicator	Green: normal; Red: I/O power supply abnormal; Off: no backplane power
	MD	Module error indicator	Green: normal Red: Module channel error Green blinking: Connected but not configured; Red and green blinking: Backplane communication abnormal;
2	00-07 10-17	Output signal indicator	Green: output "1" Off: output "0"
	Terminal disassembly device	Press the device to separate the terminal block from the module	-
3	I/O output terminal 0-7,10-17	I/O signal wiring	-
4	24 V power terminal	24 V+	-

5	24 V power terminal	0 V	-
6	Module fixing device	Used to fix the module to the standard mounting rail	Pulling up: assembling position; Pressing down: locking position
7	Backplane expansion interface	Backplane communication	-

6.4.2.4. 16-channel digital output module technical data

FX20-DO-BH00

ARTICLE PROPERTIES

PRODUCT TYPE	FX20 series modular I/O system digital output modules	PRODUCT GROUP	IP20 modular I/O system
DESCRIPTION	FX20-submodule 16-channel output PNP, 24 V DC, 0.5 A, IP20, DIN rail installation	PU	1 pc
		COUNTRY OF ORIGIN	CN

TECHNICAL DATA

NUMBER OF DIGITAL OUTPUTS	16	SWITCHING FREQUENCY	Max. 1 kHz (Resistive loads) Max. 1 Hz (Inductive loads) Max. 10 Hz (Lamps)
OUTPUT TYPE	PNP	OUTPUT HOLD	Supports, configured by PLC or web server
OUTPUT VOLTAGE	24 V DC	CURRENT CONSUMPTION (5 V)	60 mA
OUTPUT CURRENT	Max. 0.5 A per channel, total 4 A per module	PROCESS DATA LENGTH	2 bytes
OUTPUT LOAD TYPES	Resistive loads, inductive loads, lamps	FAULT DIAGNOSIS METHOD	LED, communication message

CONNECTION DATA

WIRE CONNECTION	Plug-in terminal block	STRIPPED LENGTHS	8 ... 10 mm 0.315 ... 0.394 in
CROSS SECTION	0.08 mm ² ... 2.5 mm ² AWG 28 ... 14		

ENVIRONMENTAL REQUIREMENTS

PROTECTION CLASS	IP20	ELECTRICAL FAST TRANSIENT (EFT)	Level A, per IEC 61000-4-4
MOUNTING TYPE	DIN-35 mm rail	ELECTRO-STATIC DISCHARGE (ESD)	Level A, per IEC 61000-4-2
AMBIENT TEMPERATURE	-5 ... +60 °C	SURGE TEST	Level A, per IEC 61000-4-5
STORAGE TEMPERATURE	-25 ... +70 °C	VIBRATION RESISTANCE	4 g, per IEC 60068-2-6
RELATIVE HUMIDITY	95%, non-condensing	SHOCK RESISTANCE	15 g, per IEC 60068-2-27
OPERATING ALTITUDE	0 ... 2000 m / 0 ... 6562 ft	EU ROHS COMPLIANCE STATUS	Yes
POLLUTION DEGREE	2, per IEC 61131-2	MATERIAL COMPLIANCE	Compliant with REACH

GENERAL DATA

HOUSING MATERIAL	PPE	DIMENSIONS (H X W X D)	110.6 x 15 x 78.4 mm
WEIGHT	63 g	MTTF (25 °C)	155 years
COLOR	Light gray	APPROVALS	CE

FX20-DO-BH50

ARTICLE PROPERTIES

PRODUCT TYPE	FX20 series modular I/O system digital output modules	PRODUCT GROUP	IP20 modular I/O system
DESCRIPTION	FX20-submodule 16-channel output NPN, 24 V DC, 0.5 A, IP20, DIN rail installation	PU	1 pc
		COUNTRY OF ORIGIN	CN

TECHNICAL DATA

NUMBER OF DIGITAL OUTPUTS	16	SWITCHING FREQUENCY	Max. 1 kHz (Resistive loads) Max. 1 Hz (Inductive loads) Max. 10 Hz (Lamps)
OUTPUT TYPE	NPN	OUTPUT HOLD	Supports, configured by PLC or web server
OUTPUT VOLTAGE	24 V DC	CURRENT CONSUMPTION (5 V)	60 mA
OUTPUT CURRENT	Max. 0.5 A per channel, total 4 A per module	PROCESS DATA LENGTH	2 bytes
OUTPUT LOAD TYPES	Resistive loads, inductive loads, lamps	FAULT DIAGNOSIS METHOD	LED, communication message

CONNECTION DATA

WIRE CONNECTION	Plug-in terminal block	STRIPPED LENGTHS	8 ... 10 mm 0.315 ... 0.394 in
CROSS SECTION	0.08 mm ² ... 2.5 mm ² AWG 28 ... 14		

ENVIRONMENTAL REQUIREMENTS

PROTECTION CLASS	IP20	ELECTRICAL FAST TRANSIENT (EFT)	Level A, per IEC 61000-4-4
MOUNTING TYPE	DIN-35 mm rail	ELECTRO-STATIC DISCHARGE (ESD)	Level A, per IEC 61000-4-2
AMBIENT TEMPERATURE	-5 ... +60 °C	SURGE TEST	Level A, per IEC 61000-4-5
STORAGE TEMPERATURE	-25 ... +70 °C	VIBRATION RESISTANCE	4 g, per IEC 60068-2-6
RELATIVE HUMIDITY	95%, non-condensing	SHOCK RESISTANCE	15 g, per IEC 60068-2-27
OPERATING ALTITUDE	0 ... 2000 m / 0 ... 6562 ft	EU ROHS COMPLIANCE STATUS	Yes
POLLUTION DEGREE	2, per IEC 61131-2	MATERIAL COMPLIANCE	Compliant with REACH

GENERAL DATA

HOUSING MATERIAL	PPE	DIMENSIONS (H X W X D)	110.6 x 15 x 78.4 mm
WEIGHT	63 g	MTTF (25 °C)	155 years
COLOR	Light gray	APPROVALS	CE

6.4.2.5. 16 digital input output module profile drawing

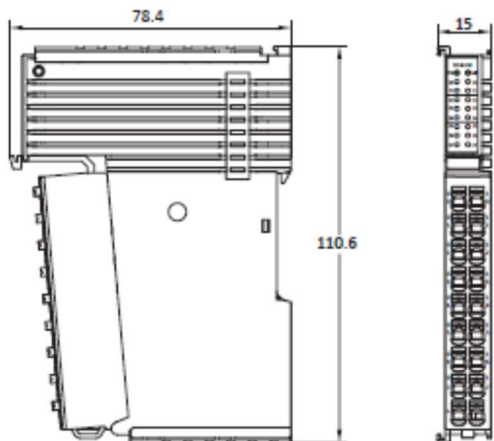

6.4.3. 32-channel digital input output module

6.4.3.1. 32-channel digital input module

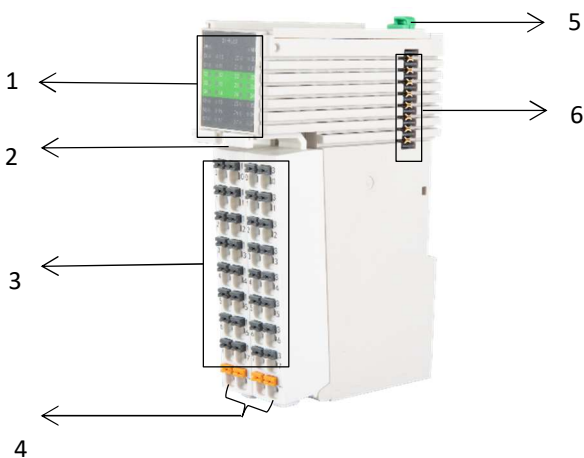

Item	Name	Function	Status
1	Module running indicator		
	PW	Backplane power indicator	Green: normal; Off: no backplane power
	MD	Module error indicator	Green: normal Red: Module channel error Green blinking: Connected but not configured; Red and green blinking: Backplane

			communication abnormal;
	00-07,10-17 20-27,30-37	Input signal indicator	Green: output "1" Off: output "0"
2	Terminal disassembly device	Press the device to separate the terminal block from the module	-
3	IO input terminal 00-07,10-17, 20-27,30-37	I/O signal wiring	-
4	Common terminals	I/O signal common terminals	0 V when the input signal is PNP, 24 V+ when the input signal is NPN
5	Module fixing device	Used to fix the module to the standard mounting rail	Pulling up: assembling position; Pressing down: locking position
6	Backplane expansion interface	Backplane communication	-

6.4.3.2. 32-channel digital input module technical data

FX20-DI-BL60

ARTICLE PROPERTIES

PRODUCT TYPE	FX20 series modular I/O system digital input modules	PRODUCT GROUP	IP20 modular I/O system
DESCRIPTION	FX20-submodule 32-channel input PNP/ NPN, 24 V DC, IP20, DIN rail installation	PU	1 pc
		COUNTRY OF ORIGIN	CN

TECHNICAL DATA

NUMBER OF DIGITAL INPUTS	32	INPUT FILTERING DELAY	0 ms, 1 ms, 3 ms and 10 ms can be configured
INPUT TYPE	PNP / NPN	CURRENT CONSUMPTION (5 V)	60 mA
INPUT SIGNAL '0'	0 ... 5 V DC	PROCESS DATA LENGTH	4 bytes
INPUT SIGNAL '1'	18 ... 30 V DC	FAULT DIAGNOSIS METHOD	LED, communication message
INPUT CURRENT PER CHANNEL FOR SIGNAL '1'	Typ. 4 mA		

CONNECTION DATA

WIRE CONNECTION	Plug-in terminal block	STRIPPED LENGTHS	8 ... 10 mm 0.315 ... 0.394 in
CROSS SECTION	0.08 mm ² ... 2.5 mm ² AWG 28 ... 14		

ENVIRONMENTAL REQUIREMENTS

PROTECTION CLASS	IP20	ELECTRICAL FAST TRANSIENT (EFT)	Level A, per IEC 61000-4-4
-------------------------	------	--	----------------------------

MOUNTING TYPE	DIN-35 mm rail	ELECTRO-STATIC DISCHARGE (ESD)	Level A, per IEC 61000-4-2
AMBIENT TEMPERATURE	-5 ... +60 °C	SURGE TEST	Level A, per IEC 61000-4-5
STORAGE TEMPERATURE	-25 ... +70 °C	VIBRATION RESISTANCE	4 g, per IEC 60068-2-6
RELATIVE HUMIDITY	95%, non-condensing	SHOCK RESISTANCE	15 g, per IEC 60068-2-27
OPERATING ALTITUDE	0 ... 2000 m / 0 ... 6562 ft	EU ROHS COMPLIANCE STATUS	Yes
POLLUTION DEGREE	2, per IEC 61131-2	MATERIAL COMPLIANCE	Compliant with REACH

GENERAL DATA

HOUSING MATERIAL	PPE	DIMENSIONS (H X W X D)	110.6 x 28.1 x 78.4 mm
WEIGHT	128 g	MTTF (25 °C)	155 years
COLOR	Light gray	APPROVALS	CE

6.4.3.3. 32-channel digital output module

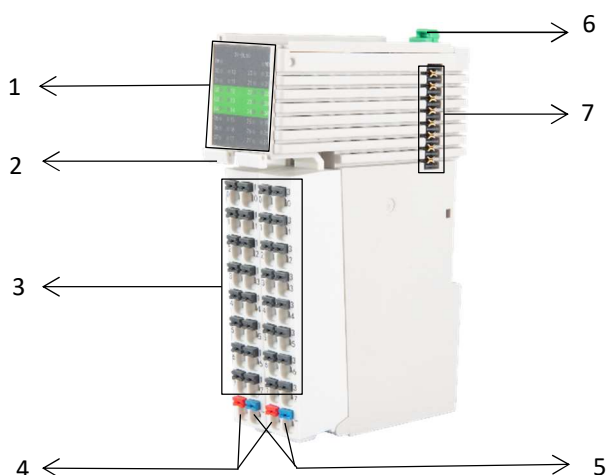

Item	Name	Function	Status
1	Module running indicators		
	PW	Backplane power indicator	Green: normal; Red: I/O power supply abnormal; Off: no backplane power
	MD	Module error indicator	Green: normal Red: Module channel error Green blinking: Connected but not configured; Red and green blinking: Backplane communication abnormal;
	00-07,10-17 20-27,30-37	Output signal indicator	Green: output "1" Off: output "0"
2	Terminal disassembly device	Press the device to separate the terminal block from the module	-

3	I/O output terminal 00-07,10-17, 20-27,30-37	I/O signal wiring	-
4	24 V power terminal	24V+	-
5	24 V power terminal	0V	-
6	Module fixing device	Used to fix the module to the standard mounting rail	Pulling up: assembling position; Pressing down: locking position
7	Backplane bus interface	Backplane communication	-

6.4.3.4. 32-channel digital output module technical data

FX20-DO-BL00

ARTICLE PROPERTIES

PRODUCT TYPE	FX20 series modular I/O system digital output modules	PRODUCT GROUP	IP20 modular I/O system
DESCRIPTION	FX20-submodule 32-channel output PNP, 24 V DC, 0.5 A, IP20, DIN rail installation	PU	1 pc
		COUNTRY OF ORIGIN	CN

TECHNICAL DATA

NUMBER OF DIGITAL OUTPUTS	32	SWITCHING FREQUENCY	Max. 1 kHz (Resistive loads) Max. 1 Hz (Inductive loads) Max. 10 Hz (Lamps)
OUTPUT TYPE	PNP	OUTPUT HOLD	Supports, configured by PLC or web server
OUTPUT VOLTAGE	24 V DC	CURRENT CONSUMPTION (5 V)	60 mA
OUTPUT CURRENT	Max. 0.5 A per channel, total 4 A per module	PROCESS DATA LENGTH	4 bytes
OUTPUT LOAD TYPES	Resistive loads, inductive loads, lamps	FAULT DIAGNOSIS METHOD	LED, communication message

CONNECTION DATA

WIRE CONNECTION	Plug-in terminal block	STRIPPED LENGTHS	8 ... 10 mm 0.315 ... 0.394 in
CROSS SECTION	0.08 mm ² ... 2.5 mm ² AWG 28 ... 14		

ENVIRONMENTAL REQUIREMENTS

PROTECTION CLASS	IP20	ELECTRICAL FAST TRANSIENT (EFT)	Level A, per IEC 61000-4-4
MOUNTING TYPE	DIN-35 mm rail	ELECTRO-STATIC DISCHARGE (ESD)	Level A, per IEC 61000-4-2
AMBIENT TEMPERATURE	-5 ... +60 °C	SURGE TEST	Level A, per IEC 61000-4-5
STORAGE TEMPERATURE	-25 ... +70 °C	VIBRATION RESISTANCE	4 g, per IEC 60068-2-6

RELATIVE HUMIDITY	95%, non-condensing	SHOCK RESISTANCE	15 g, per IEC 60068-2-27
OPERATING ALTITUDE	0 ... 2000 m / 0 ... 6562 ft	EU ROHS COMPLIANCE STATUS	Yes
POLLUTION DEGREE	2, per IEC 61131-2	MATERIAL COMPLIANCE	Compliant with REACH

GENERAL DATA

HOUSING MATERIAL	PPE	DIMENSIONS (H X W X D)	110.6 x 28.1 x 78.4 mm
WEIGHT	128 g	MTTF (25 °C)	155 years
COLOR	Light gray	APPROVALS	CE

FX20-DO-BL50

ARTICLE PROPERTIES

PRODUCT TYPE	FX20 series modular I/O system digital output modules	PRODUCT GROUP	IP20 modular I/O system
DESCRIPTION	FX20-submodule 32-channel output NPN, 24 V DC, 0.5 A, IP20, DIN rail installation	PU	1 pc
		COUNTRY OF ORIGIN	CN

TECHNICAL DATA

NUMBER OF DIGITAL OUTPUTS	32	SWITCHING FREQUENCY	Max. 1 kHz (Resistive loads) Max. 1 Hz (Inductive loads) Max. 10 Hz (Lamps)
OUTPUT TYPE	NPN	OUTPUT HOLD	Supports, configured by PLC or web server
OUTPUT VOLTAGE	24 V DC	CURRENT CONSUMPTION (5 V)	60 mA
OUTPUT CURRENT	Max. 0.5 A per channel, total 4 A per module	PROCESS DATA LENGTH	4 bytes
OUTPUT LOAD TYPES	Resistive loads, inductive loads, lamps	FAULT DIAGNOSIS METHOD	LED, communication message

CONNECTION DATA

WIRE CONNECTION	Plug-in terminal block	STRIPPED LENGTHS	8 ... 10 mm 0.315 ... 0.394 in
CROSS SECTION	0.08 mm ² ... 2.5 mm ² AWG 28 ... 14		

ENVIRONMENTAL REQUIREMENTS

PROTECTION CLASS	IP20	ELECTRICAL FAST TRANSIENT (EFT)	Level A, per IEC 61000-4-4
MOUNTING TYPE	DIN-35 mm rail	ELECTRO-STATIC DISCHARGE (ESD)	Level A, per IEC 61000-4-2
AMBIENT TEMPERATURE	-5 ... +60 °C	SURGE TEST	Level A, per IEC 61000-4-5
STORAGE TEMPERATURE	-25 ... +70 °C	VIBRATION RESISTANCE	4 g, per IEC 60068-2-6
RELATIVE HUMIDITY	95%, non-condensing	SHOCK RESISTANCE	15 g, per IEC 60068-2-27

OPERATING ALTITUDE	0 ... 2000 m / 0 ... 6562 ft	EU ROHS COMPLIANCE STATUS	Yes
POLLUTION DEGREE	2, per IEC 61131-2	MATERIAL COMPLIANCE	Compliant with REACH

GENERAL DATA

HOUSING MATERIAL	PPE	DIMENSIONS (H X W X D)	110.6 x 28.1 x 78.4 mm
WEIGHT	128 g	MTTF (25 °C)	155 years
COLOR	Light gray	APPROVALS	CE

6.4.3.5. 32-channel digital input/output module profile drawing

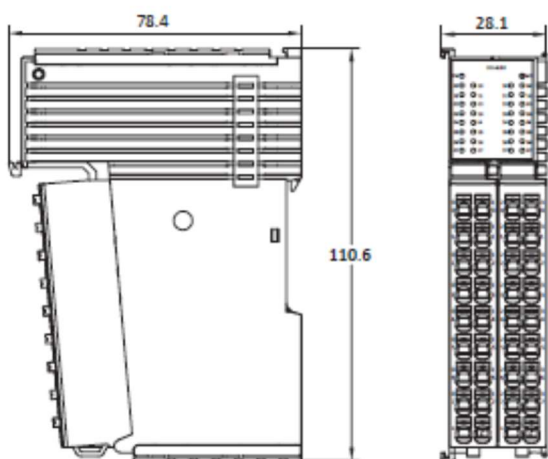

6.4.4. 4-channel analog input/output module

6.4.4.1. 4-channel analog input module

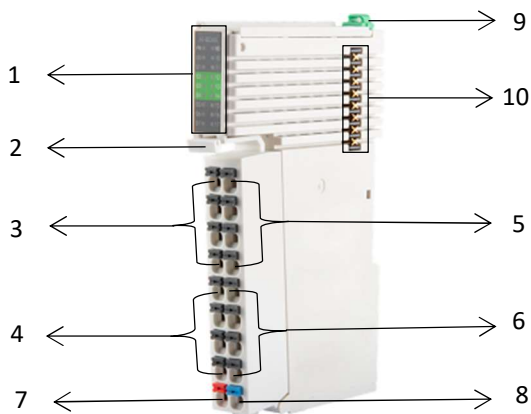

Item	Name	Function	Status
1	Module running indicators		
	PW	Backplane power indicator	Green: normal; Red: I/O power supply abnormal; Off: no backplane power
	MD	Module error indicator	Green: normal

			Red: Module channel error Green blinking: Connected but not configured; Red and green blinking: Backplane communication abnormal;
	C1-C4	Input signal indicator	Green: input normal Red: input over range
2	Terminal disassembly device	Press the device to separate the terminal block from the module	-
3	Analog input channel 0	Analog input	-
4	Analog input channel 1	Analog input	-
5	Analog input channel 2	Analog input	-
6	Analog input channel 3	Analog input	-
7	24 V power terminal	24V+	-
8	24 V power terminal	0V	-
9	Module fixing device	Used to fix the module to the standard mounting rail	Pulling up: assembling position; Pressing down: locking position
10	Backplane bus interface	Backplane communication	-

6.4.4.2. 4-channel analog input module technical data

FX20-AI-BD60

ARTICLE PROPERTIES

PRODUCT TYPE	FX20 series modular I/O system analog input modules	PRODUCT GROUP	IP20 modular I/O system
DESCRIPTION	FX20-submodule 4-channel analog input, voltage / current types, 24 V DC, IP20, DIN rail installation	PU	1 pc
		COUNTRY OF ORIGIN	CN

TECHNICAL DATA

NUMBER OF ANALOG INPUTS	4	MEASURING ACCURACY	± 0.2 %
INPUT TYPE	0 ... 10 V, ± 10 V, 1 ... 5 V, 0/4 ... 20 mA, ±20 mA	OPERATING VOLTAGE	24 V DC
INPUT IMPEDANCE	Current type: 250 Ω Voltage type: 1 MΩ	CURRENT CONSUMPTION (5 V)	60 mA
INPUT RESOLUTION	16 bits	PROCESS DATA LENGTH	8 bytes
CONVERTING TIME	3 ms	FAULT DIAGNOSIS METHOD	LED, communication message

CONNECTION DATA

WIRE CONNECTION	Plug-in terminal block	STRIPPED LENGTHS	8 ... 10 mm 0.315 ... 0.394 in
------------------------	------------------------	-------------------------	-----------------------------------

CROSS SECTION 0.08 ... 2.5 mm²
AWG 28 ... 14

ENVIRONMENTAL REQUIREMENTS

PROTECTION CLASS	IP20	ELECTRICAL FAST TRANSIENT (EFT)	Level A, per IEC 61000-4-4
MOUNTING TYPE	DIN-35 mm rail	ELECTRO-STATIC DISCHARGE (ESD)	Level A, per IEC 61000-4-2
AMBIENT TEMPERATURE	-5 ... +60 °C	SURGE TEST	Level A, per IEC 61000-4-5
STORAGE TEMPERATURE	-25 ... +70 °C	VIBRATION RESISTANCE	4 g, per IEC 60068-2-6
RELATIVE HUMIDITY	95%, non-condensing	SHOCK RESISTANCE	15 g, per IEC 60068-2-27
OPERATING ALTITUDE	0 ... 2000 m / 0 ... 6562 ft	EU ROHS COMPLIANCE STATUS	Yes
POLLUTION DEGREE	2, compliant with IEC 61131-2	MATERIAL COMPLIANCE	Compliant with REACH

GENERAL DATA

HOUSING MATERIAL	PPE	DIMENSIONS (H X W X D)	110.6 x 15 x 78.4 mm
WEIGHT	63 g	MTTF (25 °C)	196 years
COLOR	Light gray	APPROVALS	CE

6.4.4.3. 4-channel analog output module

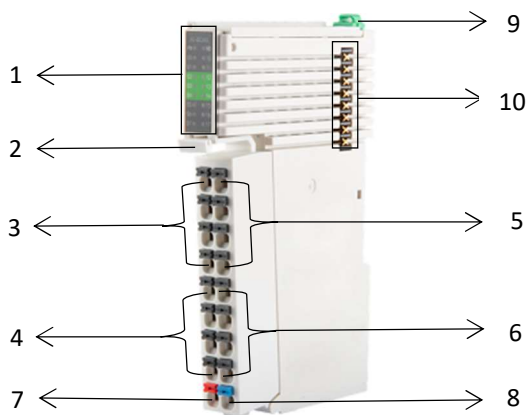

Item	Name	Function	Status
1	Module running indicators		
	PW	Backplane power indicator	Green: normal; Red: I/O power supply abnormal; Off: no backplane power
	MD	Module error indicator	Green: normal Red: Module channel error Green blinking: Connected but not be configured; Red and green blinking: Backplane communication abnormal.

	C1-C4	Output signal indicator	Green: output normal Red: output over range
2	Terminal disassembly device	Press the device to separate the terminal block from the module	-
3	Analog output 0	Analog output	-
4	Analog output 1	Analog output	-
5	Analog output 2	Analog output	-
6	Analog output 3	Analog output	-
7	24 V power terminal	24 V+	-
8	24 V power terminal	0 V	-
9	Module fixing device	Used to fix the module to the standard mounting rail	Pulling up: assembling position; Pressing down: locking position
10	Backplane bus interface	Backplane communication	

6.4.4.4. 4-channel analog output module technical data

FX20-AO-BD60

ARTICLE PROPERTIES

PRODUCT TYPE	FX20 series modular I/O system analog output modules	PRODUCT GROUP	IP20 modular I/O system
DESCRIPTION	FX20-submodule 4-channel analog output, voltage/current types, 24 V DC, IP20, DIN rail installation	PU	1 pc
		COUNTRY OF ORIGIN	CN

TECHNICAL DATA

NUMBER OF ANALOG INPUTS	4	OPERATING VOLTAGE	24 V DC
OUTPUT TYPE	0 ... 10 V, ± 10 V, 1 ... 5 V, 0/4 ... 20 mA	CURRENT CONSUMPTION (5 V)	60 mA
OUTPUT RESOLUTION	16 bits	PROCESS DATA LENGTH	8 bytes
CONVERTING TIME	2 ms	FAULT DIAGNOSIS METHOD	LED, communication message
MEASURING ACCURACY	± 0.2 %		

CONNECTION DATA

WIRE CONNECTION	Plug-in terminal block	STRIPPED LENGTHS	8 ... 10 mm 0.315 ... 0.394 in
CROSS SECTION	0.08 mm ² ... 2.5 mm ² AWG 28 ... 14		

ENVIRONMENTAL REQUIREMENTS

PROTECTION CLASS	IP20	ELECTRICAL FAST TRANSIENT (EFT)	Level A, per IEC 61000-4-4
MOUNTING TYPE	DIN-35 mm rail	ELECTRO-STATIC DISCHARGE (ESD)	Level A, per IEC 61000-4-2

AMBIENT TEMPERATURE	-5 ... +60 °C	SURGE TEST	Level A, per IEC 61000-4-5
STORAGE TEMPERATURE	-25 ... +70 °C	VIBRATION RESISTANCE	4 g, per IEC 60068-2-6
RELATIVE HUMIDITY	95%, non-condensing	SHOCK RESISTANCE	15 g, per IEC 60068-2-27
OPERATING ALTITUDE	0 ... 2000 m / 0 ... 6562 ft	EU ROHS COMPLIANCE STATUS	Yes
POLLUTION DEGREE	2, per IEC 61131-2	MATERIAL COMPLIANCE	Compliant with REACH

GENERAL DATA

HOUSING MATERIAL	PPE	DIMENSIONS (H X W X D)	110.6 x 15 x 78.4 mm
WEIGHT	63 g	MTTF (25 °C)	196 years
COLOR	Light gray	APPROVALS	CE

6.4.4.5. 4-channel analog input output module profile drawing

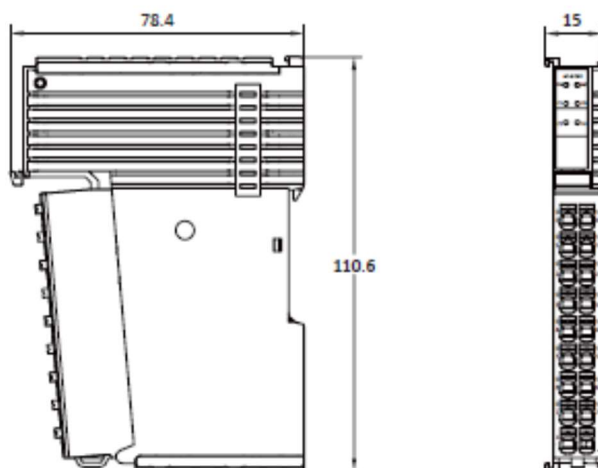

6.4.5. 8-channel analog input output modules

6.4.5.1. 8-channel analog input modules

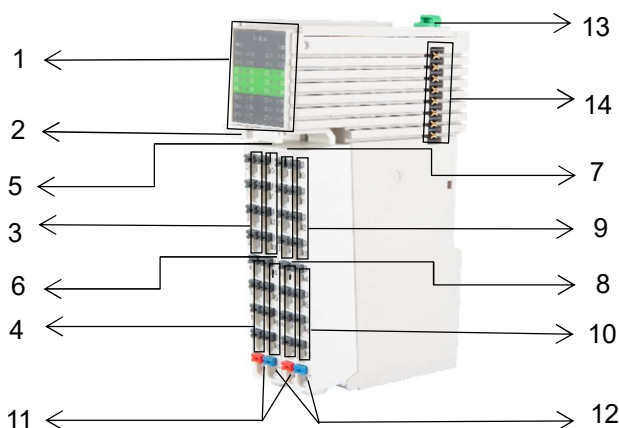

Item	Name	Function	Status
1	Module running indicators		
	PW	Backplane power indicator	Green: normal;

			Red: I/O power supply abnormal; Off: no backplane power
	MD	Module error indicator	Green: normal Red: Module channel error Green blinking: Connected but not configured; Red and green blinking: Backplane communication abnormal;
	C1-C8	Input signal indicator	Green: input normal Red: input over range
2	Terminal disassembly device	Press the device to separate the terminal block from the module	-
3	Analog input channel 0	Analog input	-
4	Analog input channel 1	Analog input	-
5	Analog input channel 2	Analog input	-
6	Analog input channel 3	Analog input	-
7	Analog input channel 4	Analog input	-
8	Analog input channel 5	Analog input	-
9	Analog input channel 6	Analog input	-
10	Analog input channel 7	Analog input	-
11	24 V power terminal	24 V+	-
12	24 V power terminal	0 V	-
13	Module fixing device	Used to fix the module to the standard mounting rail	Pulling up: assembling position; Pressing down: locking position
14	Backplane bus interface	Backplane communication	-

6.4.5.2. 8-channel analog input module technical data

FX20-AI-BF60

ARTICLE PROPERTIES

PRODUCT TYPE	FX20 series modular I/O system analog input modules	PRODUCT GROUP	IP20 modular I/O system
DESCRIPTION	FX20-submodule 8-channel analog input, voltage / current types, 24 V DC, IP20, DIN rail installation	PU	1 pc
		COUNTRY OF ORIGIN	CN

TECHNICAL DATA

NUMBER OF ANALOG INPUTS	8	MEASURING ACCURACY	± 0.2 %
INPUT TYPE	0 ... 10 V, ± 10 V, 1 ... 5 V, 0/4 ... 20 mA, ± 20 mA	OPERATING VOLTAGE	24 V DC
INPUT IMPEDANCE	Current type: 250 Ω Voltage type: 1 MΩ	CURRENT CONSUMPTION (5 V)	60 mA

INPUT RESOLUTION	16 bits	PROCESS DATA LENGTH	16 bytes
CONVERTING TIME	3 ms	FAULT DIAGNOSIS METHOD	LED, communication message

CONNECTION DATA

WIRE CONNECTION	Plug-in terminal block	STRIPPED LENGTHS	8 ... 10 mm 0.315 ... 0.394 in
CROSS SECTION	0.08 mm ² ... 2.5 mm ² AWG 28 ... 14		

ENVIRONMENTAL REQUIREMENTS

PROTECTION CLASS	IP20	ELECTRICAL FAST TRANSIENT (EFT)	Level A, per IEC 61000-4-4
MOUNTING TYPE	DIN-35 mm rail	ELECTRO-STATIC DISCHARGE (ESD)	Level A, per IEC 61000-4-2
AMBIENT TEMPERATURE	-5 ... +60 °C	SURGE TEST	Level A, per IEC 61000-4-5
STORAGE TEMPERATURE	-25 ... +70 °C	VIBRATION RESISTANCE	4 g, per IEC 60068-2-6
RELATIVE HUMIDITY	95%, non-condensing	SHOCK RESISTANCE	15 g, per IEC 60068-2-27
OPERATING ALTITUDE	0 ... 2000 m / 0 ... 6562 ft	EU ROHS COMPLIANCE STATUS	Yes
POLLUTION DEGREE	2, per IEC 61131-2	MATERIAL COMPLIANCE	Compliant with REACH

GENERAL DATA

HOUSING MATERIAL	PPE	DIMENSIONS (H X W X D)	110.6 x 28.1 x 78.4 mm
WEIGHT	128 g	MTTF (25 °C)	196 years
COLOR	Light gray	APPROVALS	CE

6.4.5.3. 8-channel analog output module

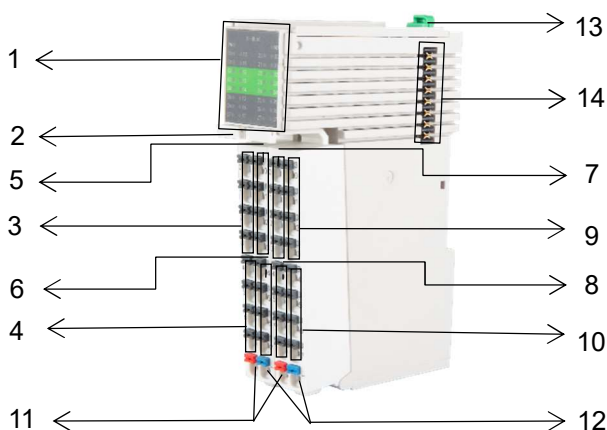

Item	Name	Function	Status
1	Module running indicator		
	PW	Backplane power indicator	Green: normal; Red: I/O power supply abnormal; Off: no backplane power

	MD	Module error indicator	Green: normal Red: Module channel error Green blinking: Connected but not configured; Red and green blinking: Backplane communication abnormal;
	C1-C8	Output signal indicator	Green: output normal Red: output over range
2	Terminal disassembly device	Press the device to separate the terminal block from the module	-
3	Analog output 0	Analog output	-
4	Analog output 1	Analog output	-
5	Analog output 2	Analog output	-
6	Analog output 3	Analog output	-
7	Analog output 4	Analog output	-
8	Analog output 5	Analog output	-
9	Analog output 6	Analog output	-
10	Analog output 7	Analog output	-
11	24 V power terminal	24 V+	-
12	24 V power terminal	0 V	-
13	Module fixing device	Used to fix the module to the standard mounting rail	Pulling up: assembling position; Pressing down: locking position
14	Backplane bus interface	Backplane communication	-

6.4.5.4. 8-channel analog output module technical data

FX20-AO-BF60

ARTICLE PROPERTIES

PRODUCT TYPE	FX20 series modular I/O system analog output modules	PRODUCT GROUP	IP20 modular I/O system
DESCRIPTION	FX20-submodule 8-channel analog output, voltage / current types, 24 V DC, IP20, DIN rail installation	PU	1 pc
		COUNTRY OF ORIGIN	CN

TECHNICAL DATA

NUMBER OF ANALOG INPUTS	8	OPERATING VOLTAGE	24 V DC
OUTPUT TYPE	0 ... 10 V, ± 10 V, 1 ... 5 V, 0/4 ... 20 mA	CURRENT CONSUMPTION (5 V)	60 mA
OUTPUT RESOLUTION	16 bits	PROCESS DATA LENGTH	16 bytes
CONVERTING TIME	2 ms	FAULT DIAGNOSIS METHOD	LED, communication message
MEASURING ACCURACY	± 0.2 %		

CONNECTION DATA

WIRE CONNECTION	Plug-in terminal block	STRIPPED LENGTHS	8 ... 10 mm, 0.315 ... 0.394 in
CROSS SECTION	0.08 mm ² ... 2.5 mm ² , AWG 28 ... 14		

ENVIRONMENTAL REQUIREMENTS

PROTECTION CLASS	IP20	ELECTRO-STATIC DISCHARGE (ESD)	Level A, per IEC 61000-4-2
MOUNTING TYPE	DIN-35 mm rail	SURGE TEST	Level A, per IEC 61000-4-5
AMBIENT TEMPERATURE	-5 ... +60 °C	VIBRATION RESISTANCE	4 g, per IEC 60068-2-6
STORAGE TEMPERATURE	-25 ... +70 °C	SHOCK RESISTANCE	15 g, per IEC 60068-2-27
RELATIVE HUMIDITY	95%, non-condensing	EU ROHS COMPLIANCE STATUS	Yes
OPERATING ALTITUDE	0 ... 2000 m / 0 ... 6562 ft	MATERIAL COMPLIANCE	Compliant with REACH
POLLUTION DEGREE	2, per IEC 61131-2	DIMENSIONS (H X W X D)	110.6 x 28 x 78.4 mm
ELECTRICAL FAST TRANSIENT (EFT)	Level A, per IEC 61000-4-4	CONFORMITY MARKING	CE

GENERAL DATA

HOUSING MATERIAL	PPE	DIMENSIONS (H X W X D)	110.6 x 28 x 78.4 mm
WEIGHT	63 g	MTTF (25 °C)	196 years
COLOR	Light gray	APPROVALS	CE

6.4.5.5. 8-channel analog input/output module profile drawing

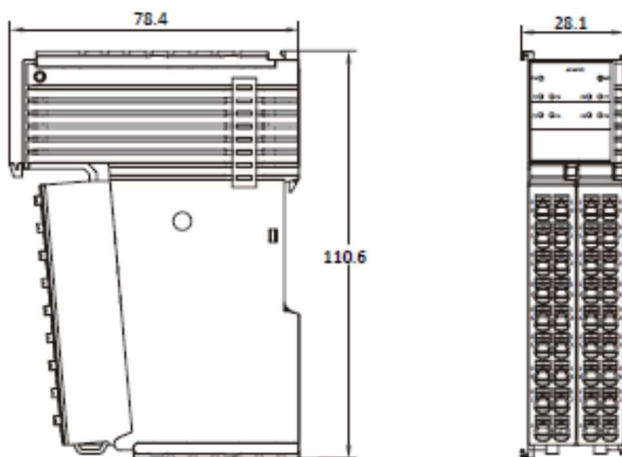

6.4.6. 4-channel temperature measurement modules

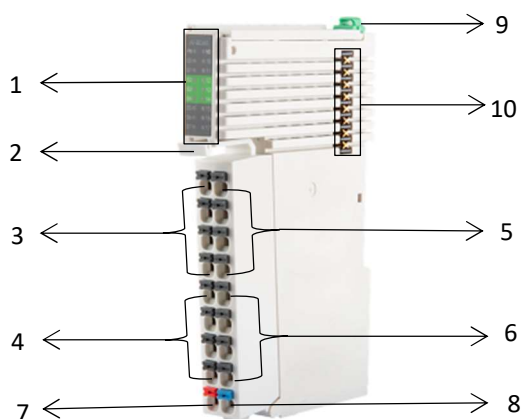

Item	Name	Function	Status
1	Module running indicators		
	PW	Backplane power indicator	Green: normal; Red: I/O power supply abnormal; Off: no backplane power
	MD	Module error indicator	Green: normal Red: Module channel error Green blinking: Connected but not configured; Red and green blinking: Backplane communication abnormal;
	C1-C4	Temperature measurement signal indicator	Green: input normal Red: input over range
2	Terminal disassembly device	Press the device to separate the terminal block from the module	-
3	Temp measurement channel 0	Analog output	-
4	Temp measurement channel 1	Analog output	-
5	Temp measurement channel 2	Analog output	-
6	Temp measurement channel 3	Analog output	-
7	24 V power terminal	24V+	-
8	24 V power terminal	0V	-
9	Module fixing device	Used to fix the module to the standard mounting rail	Pulling up: assembling position; Pressing down: locking position
10	Backplane bus interface	Backplane communication	-

6.4.6.1 4-channel temperature measurement modules technical data

FX20-AI-BD80

ARTICLE PROPERTIES

PRODUCT TYPE	FX20 series modular I/O system analog input modules	PRODUCT GROUP	IP20 modular I/O system
DESCRIPTION	FX20-submodule 4-channel RTD measurement, 24 V DC, IP20, DIN rail installation	PU	1 pc
		COUNTRY OF ORIGIN	CN

TECHNICAL DATA

NUMBER OF ANALOG INPUTS	4	MEASUREMENT ACCURACY	Within 2 °C
INPUT TYPE	Thermal resistance, (2-wire, 3-wire): PT100, PT1000	OPERATING VOLTAGE	24 V DC
INPUT RESOLUTION	16 bits	CURRENT CONSUMPTION (5 V)	60 mA
CONVERTING TIME(TYP.)	320 ms	PROCESS DATA LENGTH	8 bytes
SENSITIVITY	0.1 °C	FAULT DIAGNOSIS METHOD	LED, communication message

CONNECTION DATA

WIRE CONNECTION	Plug-in terminal block	STRIPPED LENGTHS	8 ... 10 mm, 0.315 ... 0.394 in
CROSS SECTION	0.08 mm ² ... 2.5 mm ² , AWG 28 ... 14		

ENVIRONMENTAL REQUIREMENTS

PROTECTION CLASS	IP20	ELECTRICAL FAST TRANSIENT (EFT)	Level A, per IEC 61000-4-4
MOUNTING TYPE	DIN-35 mm rail	ELECTRO-STATIC DISCHARGE (ESD)	Level A, per IEC 61000-4-2
AMBIENT TEMPERATURE	-5 ... +60 °C	SURGE TEST	Level A, per IEC 61000-4-5
STORAGE TEMPERATURE	-25 ... +70 °C	VIBRATION RESISTANCE	4 g, per IEC 60068-2-6
RELATIVE HUMIDITY	95%, non-condensing	VIBRATION RESISTANCE	4 g, per IEC 60068-2-6
OPERATING ALTITUDE	0 ... 2000 m / 0 ... 6562 ft	SHOCK RESISTANCE	15 g, per IEC 60068-2-27
HOUSING MATERIAL	PPE	EU ROHS COMPLIANCE STATUS	Yes
POLLUTION DEGREE	2, compliant with IEC 61131-2	MATERIAL COMPLIANCE	Compliant with REACH

GENERAL DATA

HOUSING MATERIAL	PPE	DIMENSIONS (H X W X D)	110.6 x 15 x 78.4 mm
WEIGHT	63 g	MTTF (25 °C)	196 years
COLOR	Light gray	APPROVALS	CE

FX20-AI-BD90

ARTICLE PROPERTIES

PRODUCT TYPE	FX20 series modular I/O system analog input modules	PRODUCT GROUP	IP20 modular I/O system
DESCRIPTION	FX20-submodule 4-channel TC measurement, 24 V DC, IP20, DIN rail installation	PU	1 pc
		COUNTRY OF ORIGIN	CN

TECHNICAL DATA

NUMBER OF ANALOG INPUTS	4	MEASUREMENT ACCURACY	Within 2 °C
INPUT TYPE	Thermocouples: J, K, T, N, E types	OPERATING VOLTAGE	24 V DC
INPUT RESOLUTION	16 bits	CURRENT CONSUMPTION (5 V)	60 mA
CONVERTING TIME(TYP.)	320 ms	PROCESS DATA LENGTH	8 bytes
SENSITIVITY	0.1 °C	FAULT DIAGNOSIS METHOD	LED, communication message

CONNECTION DATA

WIRE CONNECTION	Plug-in terminal block	STRIPPED LENGTHS	8 ... 10 mm, 0.315 ... 0.394 in
CROSS SECTION	0.08 mm ² ... 2.5 mm ² , AWG 28 ... 14		

ENVIRONMENTAL REQUIREMENTS

PROTECTION CLASS	IP20	ELECTRICAL FAST TRANSIENT (EFT)	Level A, per IEC 61000-4-4
MOUNTING TYPE	DIN-35 mm rail	ELECTRO-STATIC DISCHARGE (ESD)	Level A, per IEC 61000-4-2
AMBIENT TEMPERATURE	-5 ... +60 °C	SURGE TEST	Level A, per IEC 61000-4-5
STORAGE TEMPERATURE	-25 ... +70 °C	VIBRATION RESISTANCE	4 g, per IEC 60068-2-6
RELATIVE HUMIDITY	95%, non-condensing	SHOCK RESISTANCE	15 g, per IEC 60068-2-27
OPERATING ALTITUDE	0 ... 2000 m / 0 ... 6562 ft	EU ROHS COMPLIANCE STATUS	Yes
POLLUTION DEGREE	2, per IEC 61131-2	MATERIAL COMPLIANCE	Compliant with REACH

GENERAL DATA

HOUSING MATERIAL	PPE	DIMENSIONS (H X W X D)	110.6 x 15 x 78.4 mm
WEIGHT	63 g	MTTF (25 °C)	196 years
COLOR	Light gray	APPROVALS	CE

6.4.6.2 4-channel temperature measurement module profile drawing

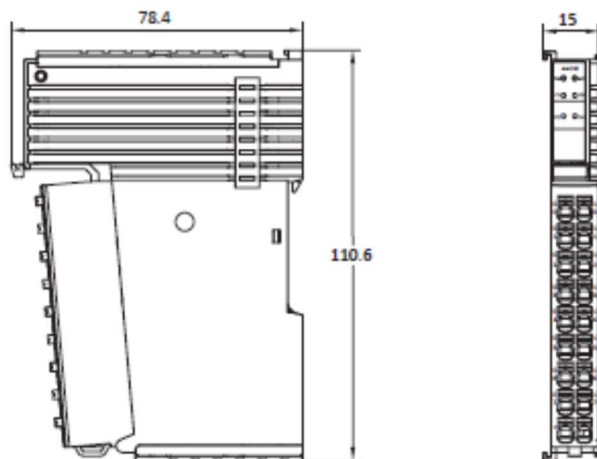

6.4.7. Auxiliary power module

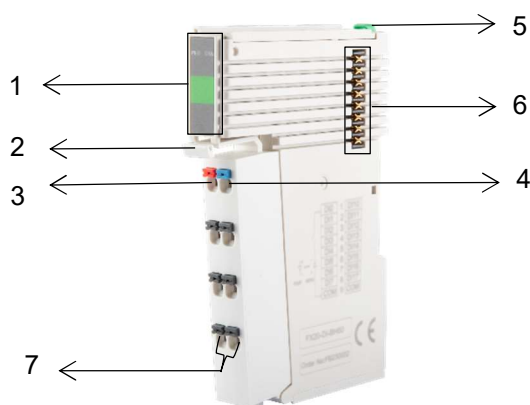

Item	Name	Function	Status
1	Module running indicators		
	PW	24 V power indicator	Green: normal Red: 24V overvoltage
	Us	Backplane power indicator	Green: normal Off: no power supply
2	Terminal disassembly device	Press the device to separate the terminal block from the module	-
3	External power supply terminal	24 V+	-
4	External power supply terminal	0 V	-
5	Module fixing device	Used to fix the module to the standard mounting rail	Pulling up: assembling position; Pressing down: locking position
6	Backplane bus interface	Backplane communication	-
7	Grounding terminal	PE	-

6.4.7.1 Auxiliary power module technical data

FX20-PS-AB00

ARTICLE PROPERTIES

PRODUCT TYPE	FX20 series modular I/O system auxiliary power supply module	PRODUCT GROUP	IP20 modular I/O system
DESCRIPTION	FX20-submodul power supply, 24 V DC, IP20, DIN rail installation, overcurrent and reverse polarity protection	PU	1 pc
		COUNTRY OF ORIGIN	CN

TECHNICAL DATA

INPUT VOLTAGE	24 V DC	OUTPUT CURRENT	Max. 3 A
INPUT VOLTAGE RANGE	20.4.....28.8 V DC	POWER PROTECTION	Overcurrent protection, power polarity reverse protection
OUTPUT VOLTAGE	5 V DC	EFFICIENCY	95%

CONNECTION DATA

WIRE CONNECTION	Plug-in terminal block	STRIPPED LENGTHS	8 ... 10 mm 0.315 ... 0.394 in
CROSS SECTION	0.08 mm ² ... 2.5 mm ² AWG 28 ... 14		

ENVIRONMENTAL REQUIREMENTS

PROTECTION CLASS	IP20	ELECTRICAL FAST TRANSIENT (EFT)	Level A, per IEC 61000-4-4
MOUNTING TYPE	DIN-35 mm rail	ELECTRO-STATIC DISCHARGE (ESD)	Level A, per IEC 61000-4-2
AMBIENT TEMPERATURE	-5 ... +60 °C	SURGE TEST	Level A, per IEC 61000-4-5
STORAGE TEMPERATURE	-25 ... +70 °C	VIBRATION RESISTANCE	4 g, per IEC 60068-2-6
RELATIVE HUMIDITY	95%, non-condensing	SHOCK RESISTANCE	15 g, per IEC 60068-2-27
OPERATING ALTITUDE	0 ... 2000 m / 0 ... 6562 ft	EU ROHS COMPLIANCE STATUS	Yes
POLLUTION DEGREE	2, per IEC 61131-2	MATERIAL COMPLIANCE	Compliant with REACH

GENERAL DATA

HOUSING MATERIAL	PPE	DIMENSIONS (H X W X D)	110.6 x 15 x 78.4 mm
WEIGHT	63 g	APPROVALS	CE
COLOR	Light gray		

6.4.7.2 Auxiliary power module profile drawing

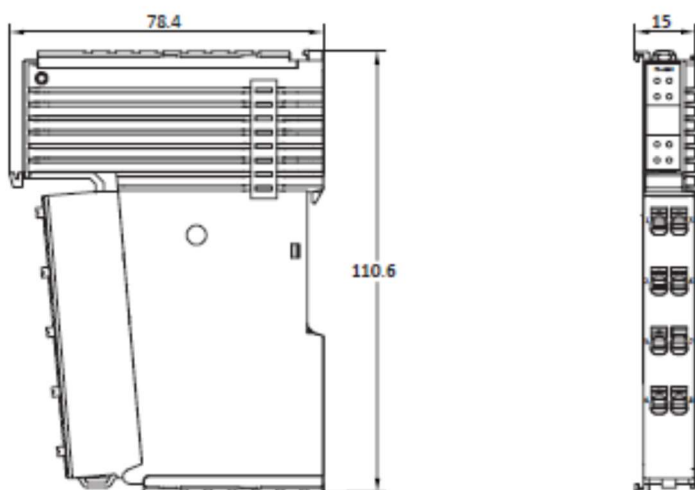

7. Mechanical installation and disassembly

7.1. Installation location and minimum installation distance

The installation position and reserved space are shown in the following figure. Install the installation guide rail horizontally to the designated installation position, and the connection surface of the connector and I/O modules must face forward.

The installation position should maintain a certain distance from adjacent electrical components or cabinets to facilitate heat dissipation. The recommended minimum installation clearance can refer to the markings in the above figure.

Ensure that FX20 is ventilated from bottom to top and achieve optimal cooling through convective ventilation.

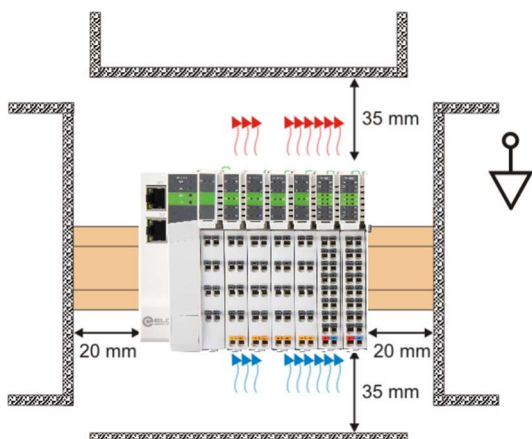

7.2. FX20 adapter installation

The installation is carried out according to the following steps:



Attention!

During installation, align the module with the DIN rail and press the fixing device in the direction indicated by the arrow. After installation, there will be a noticeable clicking sound; change the position of the locking device slightly; after installing the module properly, make the locking device clamp the upper edge of the rail; to avoid damaging the product, do not apply excessive force.

7.3. I/O modules installation

After the installation of the adapter, the function modules can be sequentially inserted from the right side of the adapter. Before the insertion, ensure to pull out the fixing device and aligned with the two slots on the module.



i Caution!

The end cover is only to protect the backplane bus interface of the end module, and it is packaged and shipped together with the adapter.

7.4. Modules disassembly

Use a flat screwdriver or similar tool to pry up the locking device on the rail, and then pull the module away from the DIN rail.



The wiring terminals of all modules can be removed separately to facilitate module replacement, as follows:

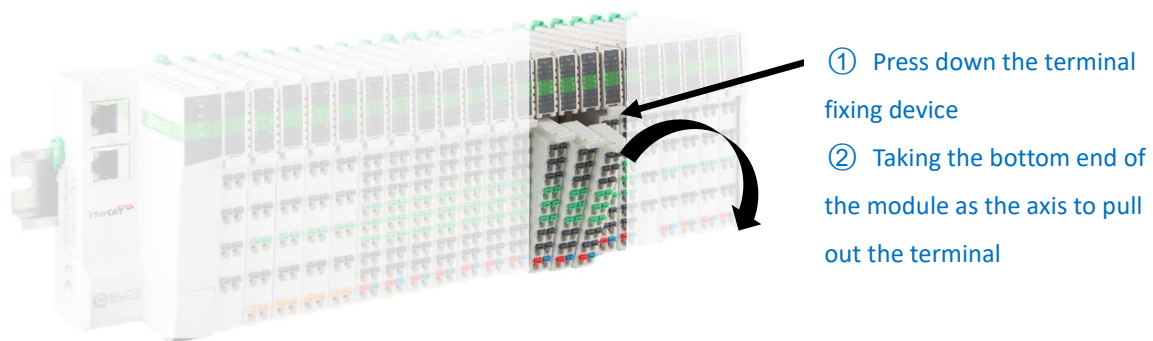

 **Warning!**

The mechanical installation and disassembly of modules require qualified professional mechanical personnel to operate and pay attention to the correct wearing and use of labor protection equipment.

8. Electrical installation and wiring

8.1. Cable specification

8.1.1. Communication cable

ModbusTCP communication uses shielded network cables for data transmission, without short circuits, misalignment, and poor contact; The length of the cable between devices cannot exceed 100m, as exceeding this length will cause signal attenuation and affect normal communication. The following specifications of communication cables are recommended:

Item	Specification
Cable type	Elastic crossover cable, S-FTP, category 5
Standards met	EIA/TIA568A,EN50173,ISO/IEC11801 EIA/TIA bulletin TSB,EIA/TIA SB40-A&TSB36
Conductor section	AWG26
Wire type	Twisted pair
Wire pair	4

Pre-wired connectors are better for communication and construction. Elco pre-wired connectors can provide customized cable material and cable length in accordance with communication technology requirements. The following Elco Ethernet connectors are available:

Model	Description
E16DA4002M020	RJ45-M12 double-ended pre-wired Ethernet connector, male straight, D-CODE, 4-pin, Cat5e, PVC, 2 M, fixed installation
E66D04002M020	RJ45-RJ45 double-ended pre-wired Ethernet connector, male straight-male straight, 4-pin, Cat5e, PVC, 2 M, fixed installation
E16DA4004M020	RJ45-M12 double-ended pre-wired Ethernet connector, male straight, D-CODE,4-pin, Cat5e, PVC, 2 M, suitable for drag chain
E66D04004M020	RJ45-RJ45 double-ended pre-wired Ethernet connector, male straight-male straight,4-pin, Cat5e, PUR,2 M, suitable for drag chain

i For more selection of Ethernet connectors, please refer to Elco's "Connectivity System Catalog".

8.1.2. Power and signal cables

The FX20 series adopts tool-free spring wiring terminals, and the wiring needs to be equipped with tube type cold pressing cable lugs. Please refer to the following figure for the stripping length and cable lug specifications:

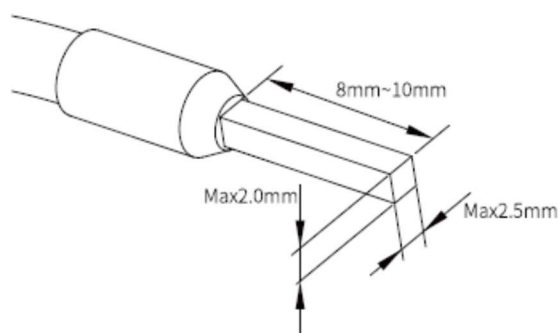

Standard cable crimper can be used for pressing the wire ear, as shown in the following figure:

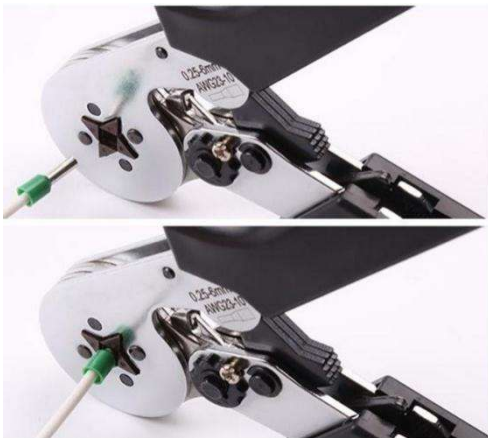

The wire connection does not need tools, and the wiring method is as follows:

- 1) Install the wire ear on the wire;
- 2) Insert the wire installed with the wire ear into the plug-in terminal to its most;
- 3) Pull the cable to ensure its fixed securely.

To release the wire:

- 1) Press the terminal spring button with your hand or a flat screwdriver
- 2) Pull out the wire and release the button.

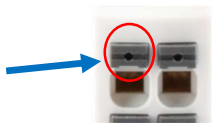

8.2. Modules wiring diagram

8.2.1. FX20 system power supply diagram

The FX20 series backplane 5VDC power supply is provided by the adapter, and IO power supply for function module needs to provide separately. Additionally, an auxiliary power supply module can provide a larger backplane power supply current. The power supply system diagram is as follows:

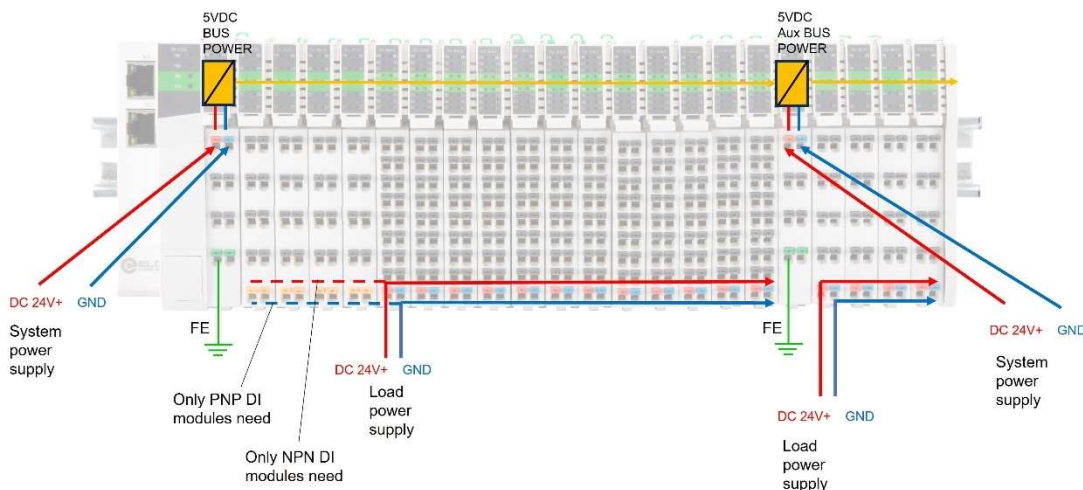

Warning!

- Be sure to disconnect all power connections before wiring!
- To ensure safety, must reliably connect the module grounding terminal to the ground!
- The wiring work must be operated by authorized electrical personnel to ensure safety!
- Using cables that do not meet the requirements will result in serious equipment damage or personal injury!

Please refer to this manual or the wiring diagram printed on the side of the module for wiring. Incorrect wiring will cause module damage or personal injury!

8.2.2. Bus adapters wiring diagram

8.2.3. ModbusTCP bus adapters wiring diagram

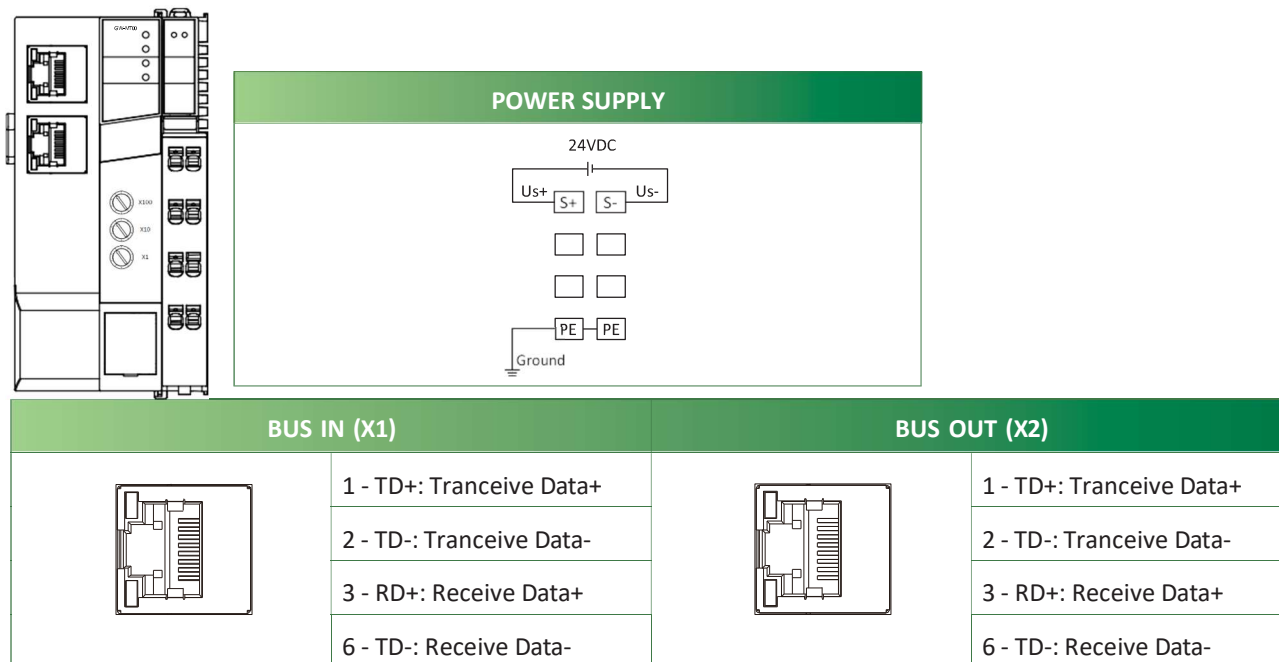

8.2.4. 8-channel DI module wiring diagram and I/O mapping

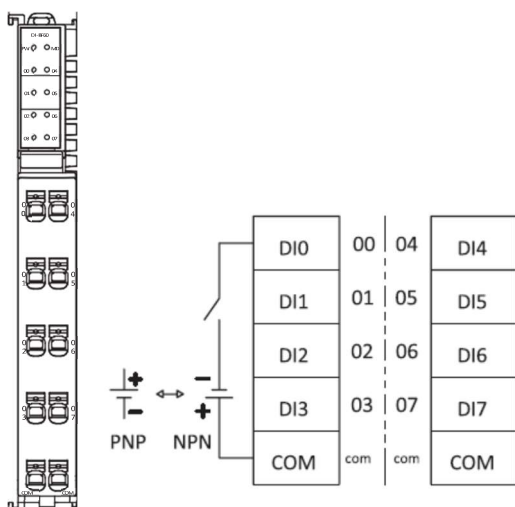

Model: FX20-DI-BF60

Input	Terminal No.	07	06	05	04	03	02	01	00
Byte 0	Address	I n.7	I n.6	I n.5	I n.4	I n.3	I n.2	I n.1	I n.0
	Byte 0	Bit 7	Bit 6	Bit 5	Bit 4	Bit 3	Bit 2	Bit 1	Bit 0

n: Starting byte of configuration

8.2.5. 8-channel DO PNP module wiring diagram and I/O mapping

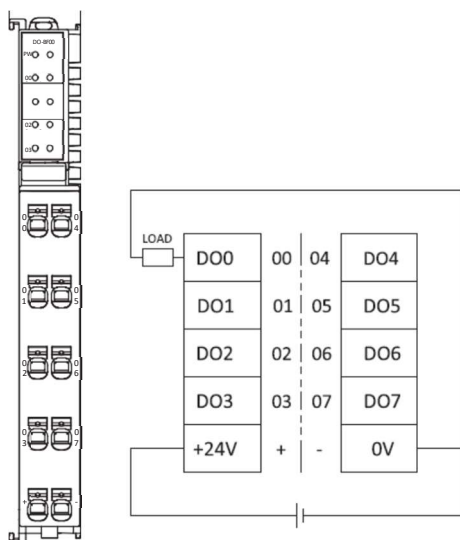

Model: FX20-DO-BF00

Output	Terminal No.	07	06	05	04	03	02	01	00
Byte 0	Address	Q n.7	Q n.6	Q n.5	Q n.4	Q n.3	Q n.2	Q n.1	Q n.0
	Byte 0	Bit 7	Bit 6	Bit 5	Bit 4	Bit 3	Bit 2	Bit 1	Bit 0

n: Starting byte of configuration

8.2.6. 8-channel DO NPN module wiring diagram and I/O mapping

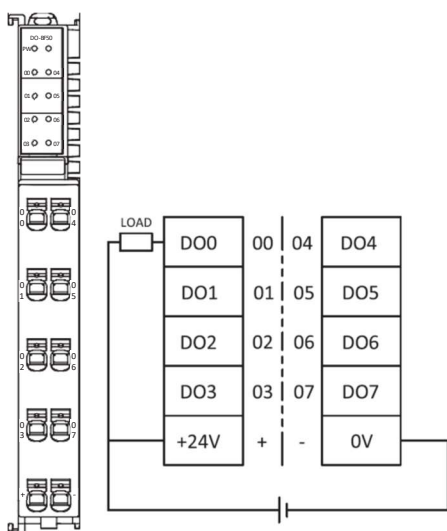

Model: FX20-DO-BF50

Output	Terminal No.	07	06	05	04	03	02	01	00
Byte 0	Address	Q n.7	Q n.6	Q n.5	Q n.4	Q n.3	Q n.2	Q n.1	Q n.0
	Byte 0	Bit 7	Bit 6	Bit 5	Bit 4	Bit 3	Bit 2	Bit 1	Bit 0

n: Starting byte of configuration

8.2.7. 4-channel SSR (AC) output module wiring diagram I/O mapping

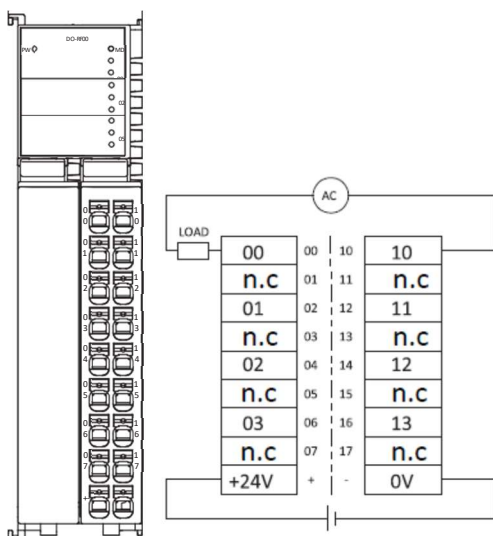

Model: FX20-DO-RD00

Output	Terminal No.	07	06	05	04	03	02	01	00
Byte 0	Address	-	-	-	-	Q n.3	Q n.2	Q n.1	Q n.0
	Byte 0	-	-	-	-	Bit 3	Bit 2	Bit 1	Bit 0
-	Terminal No.	17	16	15	14	13	12	11	10
-	Address	-	-	-	-	-	-	-	-

n: Starting byte of configuration

8.2.8. 8-channel relay output module wiring diagram and I/O mapping

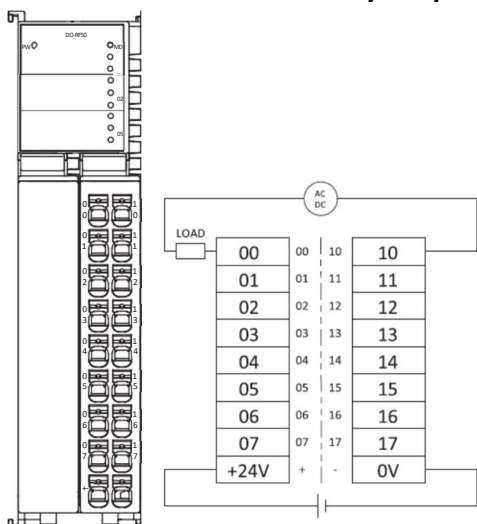

Model: FX20-DO-RF50

Output	Terminal No.	07	06	05	04	03	02	01	00
Byte 0	Address	Q n.7	Q n.6	Q n.5	Q n.4	Q n.3	Q n.2	Q n.1	Q n.0
	Byte 0	Bit 7	Bit 6	Bit 5	Bit 4	Bit 3	Bit 2	Bit 1	Bit 0
-	Terminal No.	17	16	15	14	13	12	11	10
-	Address	-	-	-	-	-	-	-	-

n: Starting byte of configuration

8.2.9. 16-channel DI module wiring diagram and I/O mapping

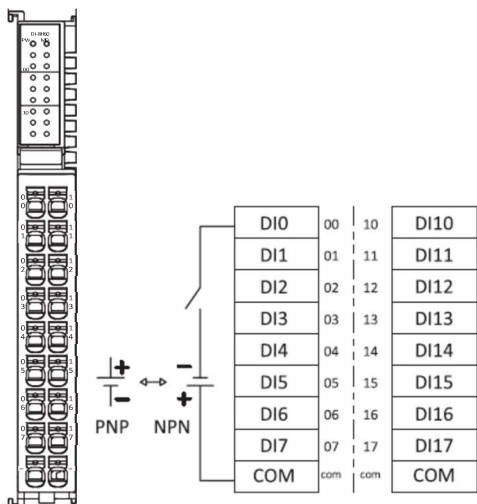

Model: FX20-DI-BH60

Input	Terminal No.	07	06	05	04	03	02	01	00
Byte 0	Address	I n.7	I n.6	I n.5	I n.4	I n.3	I n.2	I n.1	I n.0
	Byte 0	Bit 7	Bit 6	Bit 5	Bit 4	Bit 3	Bit 2	Bit 1	Bit 0
Input	Terminal No.	17	16	15	14	13	12	11	10
Byte 1	Address	I(n+1).7	I(n+1).6	I(n+1).5	I(n+1).4	I(n+1).3	I(n+1).2	I(n+1).1	I(n+1).0
	Byte 1	Bit 7	Bit 6	Bit 5	Bit 4	Bit 3	Bit 2	Bit 1	Bit 0

n: Starting byte of configuration

8.2.10. 16-channel DO PNP module wiring diagram and I/O mapping

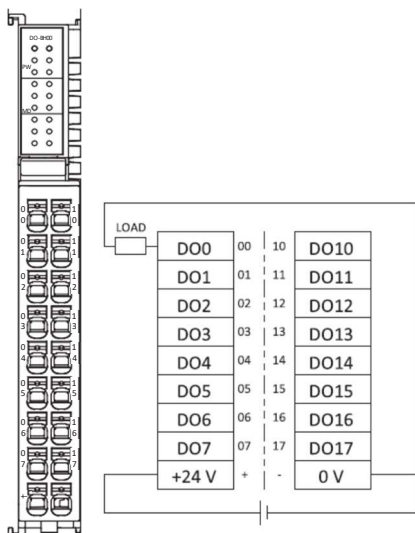

Model: FX20-DO-BH00

Output	Terminal No.	07	06	05	04	03	02	01	00
Byte 0	Address	Q n.7	Q n.6	Q n.5	Q n.4	Q n.3	Q n.2	Q n.1	Q n.0
	Byte 0	Bit 7	Bit 6	Bit 5	Bit 4	Bit 3	Bit 2	Bit 1	Bit 0
Output	Terminal No.	17	16	15	14	13	12	11	10

Byte 1	Address	Q(n+1).7	Q(n+1).6	Q (n+1).5	Q(n+1).4	Q(n+1).3	Q (n+1).2	Q (n+1).1	Q (n+1).0
	Byte 1	Bit 7	Bit 6	Bit 5	Bit 4	Bit 3	Bit 2	Bit 1	Bit 0

n: Starting byte of configuration

8.2.11. 16-channel DO NPN module wiring diagram and I/O mapping

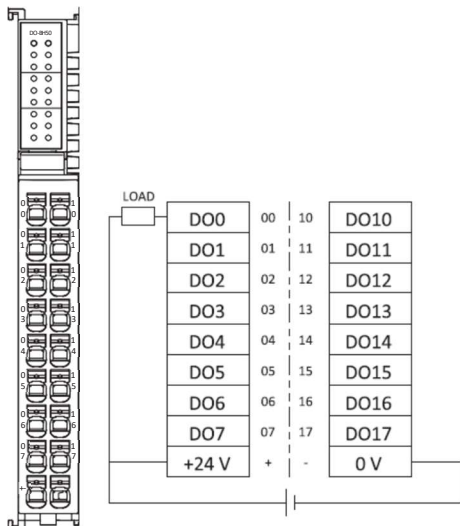

Model: FX20-DO-BH50

Output	Terminal No.	07	06	05	04	03	02	01	00
t	Address	Q n.7	Q n.6	Q n.5	Q n.4	Q n.3	Q n.2	Q n.1	Q n.0
Byte 0	Byte 0	Bit 7	Bit 6	Bit 5	Bit 4	Bit 3	Bit 2	Bit 1	Bit 0
Output	Terminal No.	17	16	15	14	13	12	11	10
t	Address	Q(n+1).7	Q(n+1).6	Q (n+1).5	Q(n+1).4	Q(n+1).3	Q (n+1).2	Q (n+1).1	Q (n+1).0
Byte 1	Byte 1	Bit 7	Bit 6	Bit 5	Bit 4	Bit 3	Bit 2	Bit 1	Bit 0

n: Starting byte of configuration

8.2.12. 32-channel DI module wiring diagram and I/O mapping

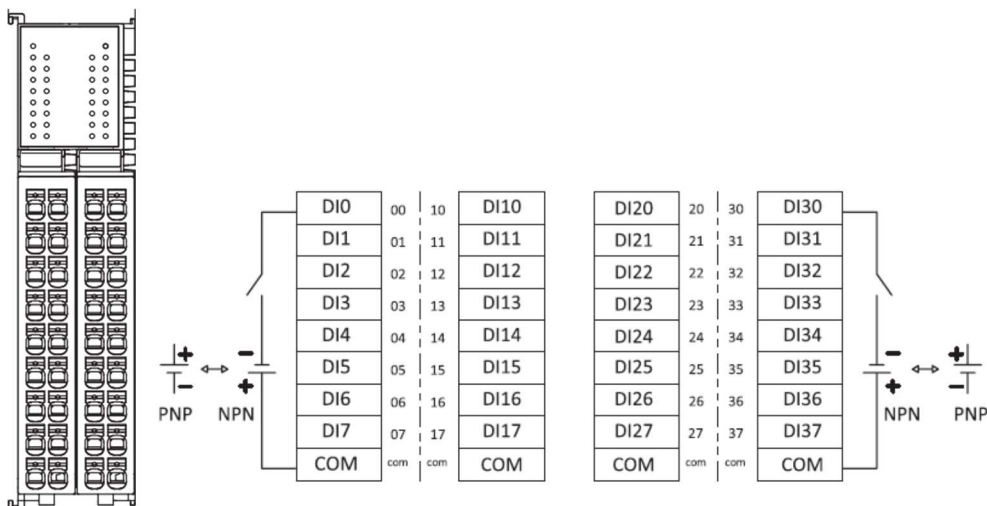

Model: FX20-DI-BL60

Input	Terminal No.	07	06	05	04	03	02	01	00
Byte 0	Address	I n.7	I n.6	I n.5	I n.4	I n.3	I n.2	I n.1	I n.0
	Byte 0	Bit 7	Bit 6	Bit 5	Bit 4	Bit 3	Bit 2	Bit 1	Bit 0
Input	Terminal No.	17	16	15	14	13	12	11	10
Byte 1	Address	I(n+1).7	I(n+1).6	I(n+1).5	I(n+1).4	I(n+1).3	I(n+1).2	I(n+1).1	I(n+1).0
	Byte 1	Bit 7	Bit 6	Bit 5	Bit 4	Bit 3	Bit 2	Bit 1	Bit 0
Input	Terminal No.	27	26	25	24	23	22	21	20
Byte 2	Address	I(n+2).7	I(n+2).6	I(n+2).5	I(n+2).4	I(n+2).3	I(n+2).2	I(n+2).1	I(n+2).0
	Byte 2	Bit 7	Bit 6	Bit 5	Bit 4	Bit 3	Bit 2	Bit 1	Bit 0
Input	Terminal No.	37	36	35	34	33	32	31	30
Byte 3	Address	I(n+3).7	I(n+3).6	I(n+3).5	I(n+3).4	I(n+3).3	I(n+3).2	I(n+3).1	I(n+3).0
	Byte 3	Bit 7	Bit 6	Bit 5	Bit 4	Bit 3	Bit 2	Bit 1	Bit 0

n: Starting byte of configuration

8.2.13. 32-channel DO PNP module wiring diagram and I/O mapping

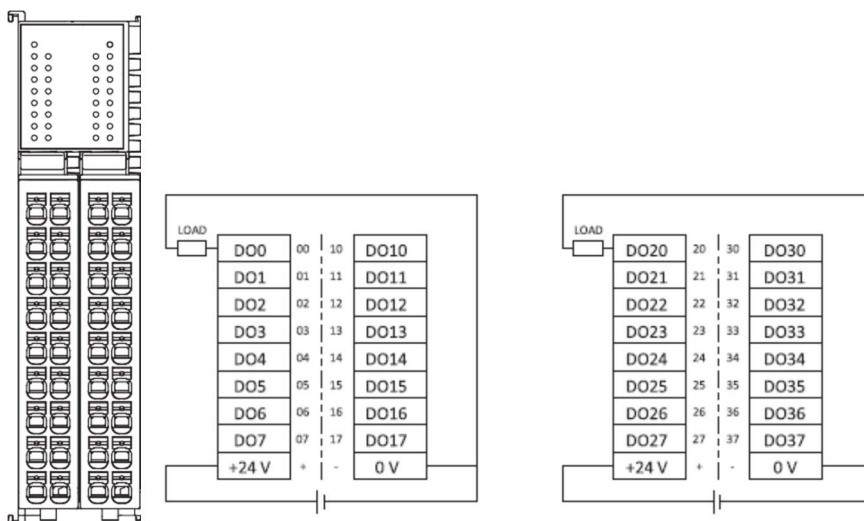

Model: FX20-DO-BL00

Output	Terminal No.	07	06	05	04	03	02	01	00
Byte 0	Address	Q n.7	Q n.6	Q n.5	Q n.4	Q n.3	Q n.2	Q n.1	Q n.0
	Byte 0	Bit 7	Bit 6	Bit 5	Bit 4	Bit 3	Bit 2	Bit 1	Bit 0
Output	Terminal No.	17	16	15	14	13	12	11	10
Byte 1	Address	Q(n+1).7	Q(n+1).6	Q (n+1).5	Q(n+1).4	Q(n+1).3	Q (n+1).2	Q (n+1).1	Q (n+1).0
	Byte 1	Bit 7	Bit 6	Bit 5	Bit 4	Bit 3	Bit 2	Bit 1	Bit 0
Output	Terminal No.	27	26	25	24	23	22	21	20
Byte 2	Address	Q(n+2).7	Q(n+2).6	Q (n+2).5	Q(n+2).4	Q(n+2).3	Q (n+2).2	Q (n+2).1	Q (n+2).0
	Byte 2	Bit 7	Bit 6	Bit 5	Bit 4	Bit 3	Bit 2	Bit 1	Bit 0
Output	Terminal No.	37	36	35	34	33	32	31	30
Byte 3	Address	Q(n+3).7	Q(n+3).6	Q (n+3).5	Q(n+3).4	Q(n+3).3	Q (n+3).2	Q (n+3).1	Q (n+3).0
	Byte 3	Bit 7	Bit 6	Bit 5	Bit 4	Bit 3	Bit 2	Bit 1	Bit 0

n: Starting byte of configuration

8.2.14. 32-channel DO NPN module wiring diagram and I/O mapping

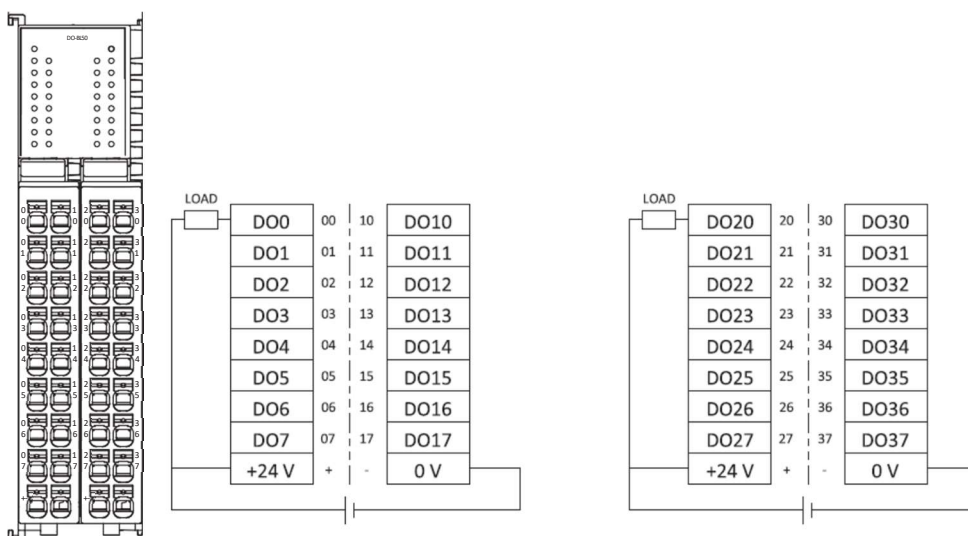

Model: FX20-DO-BL50

Output	Terminal No.	07	06	05	04	03	02	01	00
Byte 0	Address	Q n.7	Q n.6	Q n.5	Q n.4	Q n.3	Q n.2	Q n.1	Q n.0
	Byte 0	Bit 7	Bit 6	Bit 5	Bit 4	Bit 3	Bit 2	Bit 1	Bit 0
Output	Terminal No.	17	16	15	14	13	12	11	10
Byte 1	Address	Q(n+1).7	Q(n+1).6	Q (n+1).5	Q(n+1).4	Q(n+1).3	Q (n+1).2	Q (n+1).1	Q (n+1).0
	Byte 1	Bit 7	Bit 6	Bit 5	Bit 4	Bit 3	Bit 2	Bit 1	Bit 0
Output	Terminal No.	27	26	25	24	23	22	21	20
Byte 2	Address	Q(n+2).7	Q(n+2).6	Q (n+2).5	Q(n+2).4	Q(n+2).3	Q (n+2).2	Q (n+2).1	Q (n+2).0
	Byte 2	Bit 7	Bit 6	Bit 5	Bit 4	Bit 3	Bit 2	Bit 1	Bit 0
Output	Terminal No.	37	36	35	34	33	32	31	30
Byte 3	Address	Q(n+3).7	Q(n+3).6	Q (n+3).5	Q(n+3).4	Q(n+3).3	Q (n+3).2	Q (n+3).1	Q (n+3).0
	Byte 3	Bit 7	Bit 6	Bit 5	Bit 4	Bit 3	Bit 2	Bit 1	Bit 0

n: Starting byte of configuration

8.2.15. 4-channel AI module wiring diagram and I/O mapping

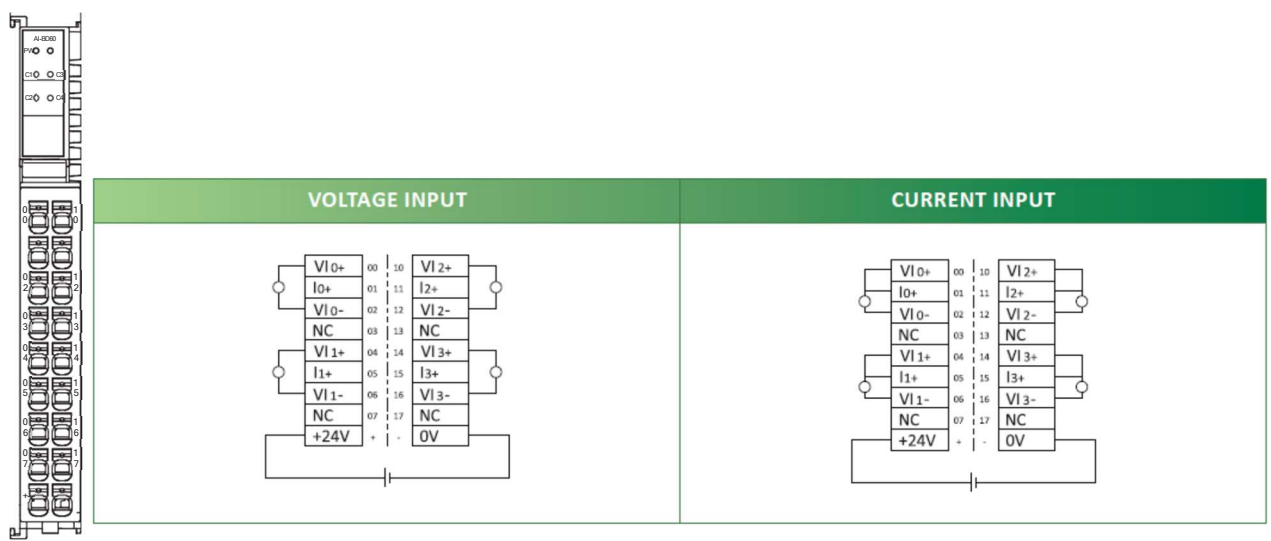

Model: FX20-AI-BD60								
Terminal No.	07	06	05	04	03	02	01	00
Address	IW n+2				IW n			
Channel	Channel 1				Channel 0			
Terminal No.	17	16	15	14	13	12	11	10
Address	IW n+6				IW n+4			
Channel	Channel 3				Channel 2			
n: Starting byte of configuration								

8.2.16. 4-channel AO module wiring diagram and I/O mapping

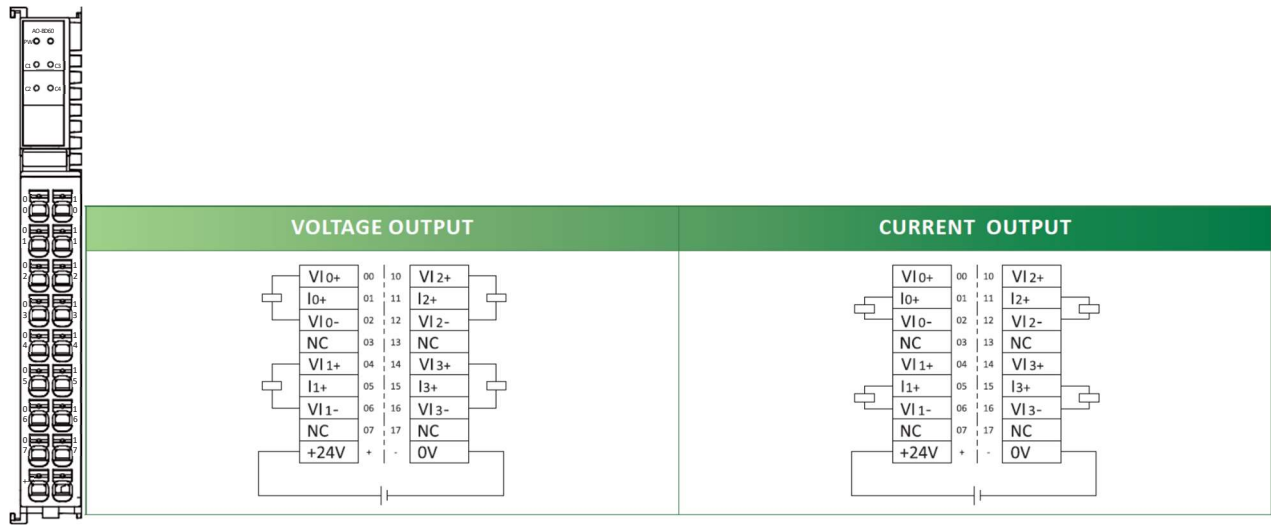

Model: FX20-AO-BD60

Terminal No.	07	06	05	04	03	02	01	00
Address	QW n+2				QW n			
Channel	Channel 1				Channel 0			
Terminal No.	17	16	15	14	13	12	11	10
Address	QW n+6				QW n+4			
Channel	Channel 3				Channel 2			

n: Starting byte of configuration

8.2.17. 8-channel AI module wiring diagram and I/O mapping

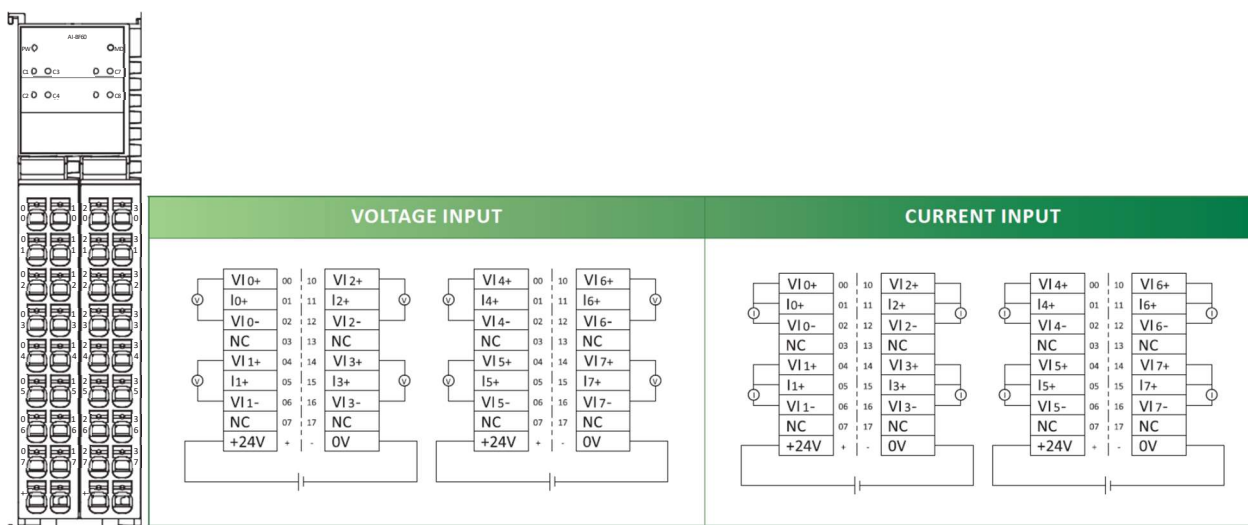

Model: FX20-AI-BF60

Terminal No.	07	06	05	04	03	02	01	00
Address	IW n+2				IW n			
Channel	Channel 1				Channel 0			
Terminal No.	17	16	15	14	13	12	11	10
Address	IW n+6				IW n+4			
Channel	Channel 3				Channel 2			
Terminal No.	27	26	25	24	23	22	21	20
Address	IW n+10				IW n+8			
Channel	Channel 5				Channel 4			
Terminal No.	37	36	35	34	33	32	31	30
Address	IW n+14				IW n+12			
Channel	Channel 7				Channel 6			

n: Starting byte of configuration

8.2.18. 8-channel AO module wiring diagram and I/O mapping

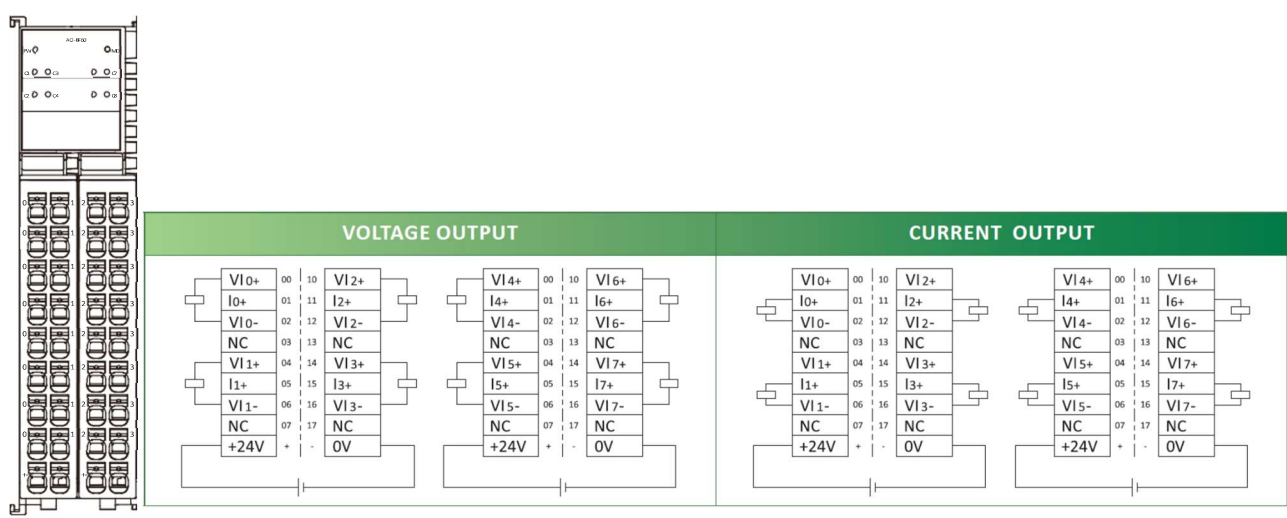

Model: FX20-AO-BF60

Terminal No.	07	06	05	04	03	02	01	00
Address	QW n+2				QW n			
Channel	Channel 1				Channel 0			
Terminal No.	17	16	15	14	13	12	11	10
Address	QW n+6				QW n+4			
Channel	Channel 3				Channel 2			
Terminal No.	27	26	25	24	23	22	21	20
Address	QW n+10				QW n+8			
Channel	Channel 5				Channel 4			
Terminal No.	37	36	35	34	33	32	31	30
Address	QW n+14				QW n+12			
Channel	Channel 7				Channel 6			

n: Starting byte of configuration

8.2.19. 4-channel RTD module wiring diagram and I/O mapping

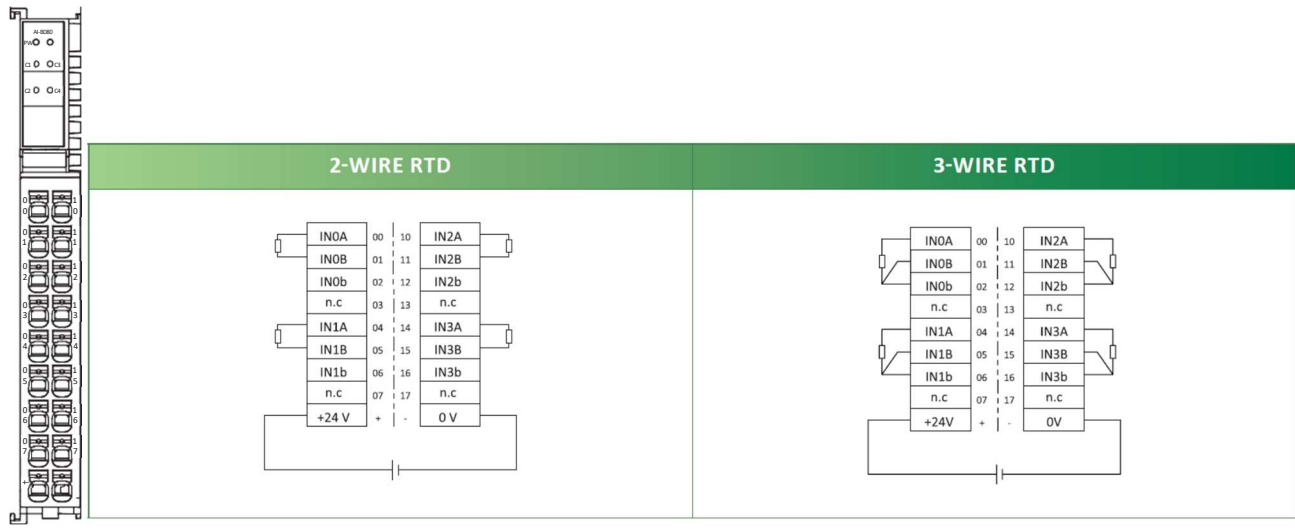

Model: FX20-AI-BD80								
Terminal No.	07	06	05	04	03	02	01	00
Address	IW n+2				IW n			
Channel	Channel 1				Channel 0			
Terminal No.	17	16	15	14	13	12	11	10
Address	IW n+6				IW n+4			
Channel	Channel 3				Channel 2			
n: Starting byte of configuration								

8.2.20. 4-channel TC module wiring diagram and I/O mapping

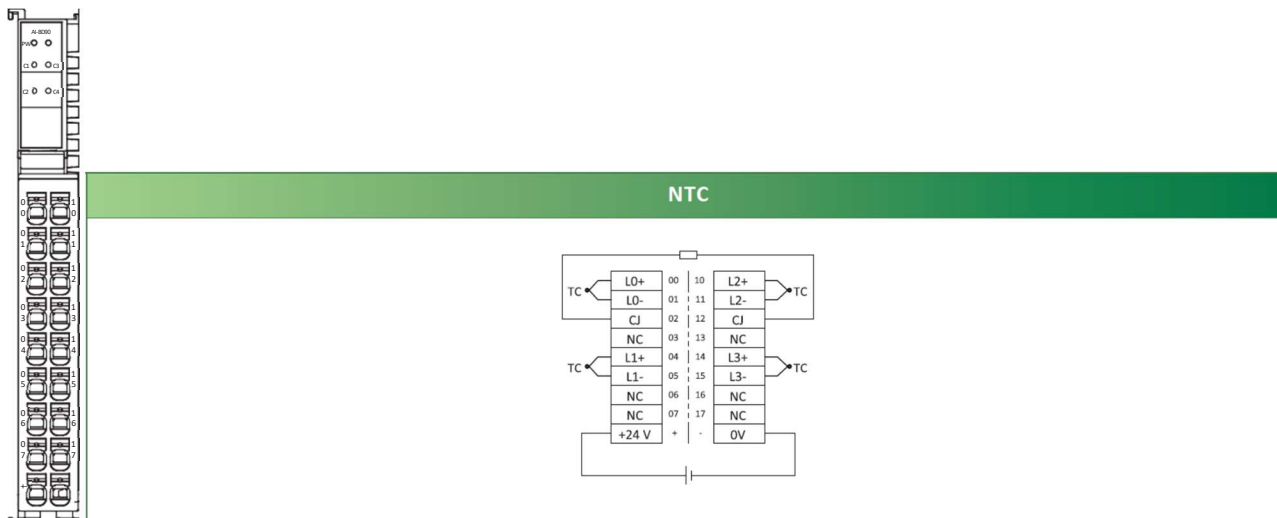

Model: FX20-AI-BD90								
Terminal No.	07	06	05	04	03	02	01	00
Address	IW n+2				IW n			
Channel	Channel 1				Channel 0			
Terminal No.	17	16	15	14	13	12	11	10
Address	IW n+6				IW n+4			
Channel	Channel 3				Channel 2			
n: Starting byte of configuration								

8.2.21. Auxiliary power module wiring diagram

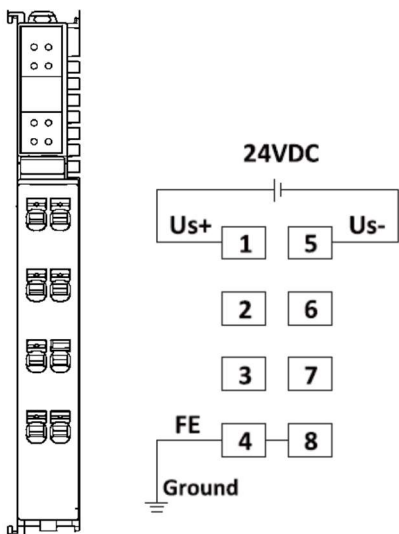

Warning!

- Module wiring diagrams are printed on the side of the module for easy reference during wiring and debugging.
- Only electrical technicians can carry out wiring and related operations.

9. Configuration and test

9.1. IP address setting for ModbusTCP adapter

The ModbusTCP adapter can easily set the IP address through rotary switches or web server.

9.1.1. Set the IP address through the rotary switches

The ModbusTCP adapter can set the IP address through three rotary switches, with a range of 192.168.0.1~192.168.0.254, meaning that the rotary switches can only set the "192.168.0. x" network segment.

The address magnification of the rotary switches from top to bottom is $\times 100$, $\times 10$, and $\times 1$, as shown in the following figure:

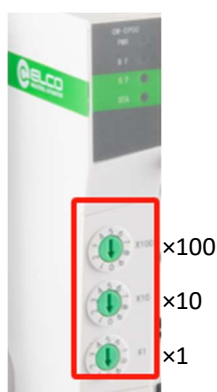

Setting method:

- 1) Power off the adapter;
- 2) Use a flathead screwdriver to turn the three rotary switches to the desired IP address. The final IP address is the sum of the three rotary switches multiplied by the multiplier, and the valid address is 1-254;
- 3) Power on again, and after successful initialization, the adapter will work under the new IP address.

9.1.2. Set IP address using FX20 web server

When the range of IP addresses cannot meet the actual needs, the FX20 web server can be accessed through a PC to set the IP address. The method is as follows:

- 1) Turn the FX20 address rotary switches to "000".
- 2) Set the IP address of the PC to be in the same network segment as the default address of FX20, such as setting the PC IP address to 192.168.0.100.
- 3) Disconnect the network connection cable between FX20 and other controllers, and connect the PC to any network port of FX20 through an Ethernet cable.
- 4) Enter the current IP address of FX20 in the address bar of the PC browser. If the current address of FX20 is 192.168.0.10, press enter to access the homepage of the FX20 Web server page.

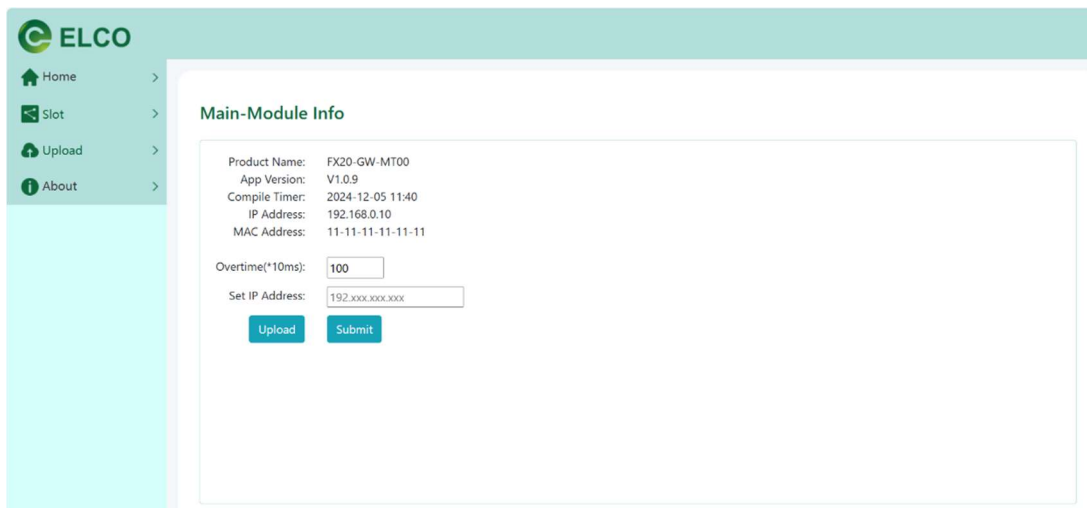

5) In the Set IP Address field, enter the desired new IP address, such as 192.168.0.111, and click the "submit" button.



6) After restarting the power supply of FX20, it will operate under the new IP address.

9.1.3. Reset IP address

If you previously configured an IP address using a web server and want to switch back to the rotary switch mode or forget the current IP address, you can restore it to the 192.168.0. x network segment by following these steps:

- Turn off the FX20, set all the rotary switches to "9", and power it on again. The FX20 will delete the IP configuration.
- Power off FX20 again, dial the rotary switches to any IP address that needs to be set from "1" to "254", and then power it back on. The IP address will be set to 192.168.0. x (where x is the address displayed by the rotary switches).

9.2. ModbusTCP Operation Instructions

9.2.1. Function code

The function codes supported by the FX20 ModbusTCP adapter are as follows:

Code	Function	Unit	Number	Offset
01	Read coil status	Bit	Single or Multiple	1 bit
02	Read discrete input states	Bit	Single or Multiple	1 bit
03	Read holding register	Word	Single or Multiple	1 word

04	Read input register	Word	Single or Multiple	1 word
05	Force single coil	Bit	Single	1 bit
06	Write a single hold register	Word	Single	1 word
15	Force multiple coils	Bit	Multiple	1 bit
16	Write multiple hold registers	Word	Multiple	1 word

The access addresses for I/O modules are as follows:

Module Type	Base address	Max. length	Unit
DI	0x0000	128 Byte	Word
DO	0x1000	128 Byte	Word
AI	0x2000	512 Byte	Word
AO	0x3000	512 Byte	Word
DI	0x4000	128 Byte	Bit
DO	0x5000	128 Byte	Bit

9.2.2. Module data reading

9.2.2.1. DI modules data reading

Function codes	Base address	Max. offset address	Operation type	Function
02	0x4000	0x0400	Bit reading	Read discrete input states
03	0x0000	0x0040	Word reading	Read holding register

9.2.2.2. DO modules data reading and writing

Function codes	Base address	Max. offset address	Operation type	Function
01	0x5000	0x0400	Bit reading	Read coil status
05	0x5000	0x0400	Bit writing	Force single coil
15	0x5000	0x0400	Bit writing	Force multiple coils
03	0x1000	0x0040	Word reading	Read holding register
06	0x1000	0x0040	Word writing	Write a single hold register
16	0x1000	0x0040	Word writing	Write multiple hold registers

9.2.2.3. AI modules data reading

Function codes	Base address	Max. offset address	Operation type	Function
03	0x2000	0x0100	Word reading	Read holding register
04	0x2000	0x0100	Word reading	Read input register

9.2.2.4. AO modules data reading and writing

Function codes	Base address	Max. offset address	Operation type	Function
03	0x3000	0x0100	Word reading	Read holding register
06	0x3000	0x0100	Word writing	Write a single hold register
16	0x3000	0x0100	Word writing	Write multiple hold registers

9.2.3. Error Code Query

Function code: 0x03; Access address: base address (0x9000) +offset address. Suggest querying with a length of 4 bytes.

Note: Read all incorrect access addresses as 0x9000, with 14 registers.

Function codes	Base address	Max. offset address	Operation type	Function
03	0x9000	0x0014	Word reading	Read holding register

9.2.3.1. Error Type Description

Error Type	Base address	Offset address	Length	Description
Connection	0x9000	0x00	4 bytes	2 registers
Short circuit	0x9000	0x02	4 bytes	2 registers
Over load	0x9000	0x04	4 bytes	2 registers
Undervoltage	0x9000	0x06	4 bytes	2 registers
Overvoltage	0x9000	0x08	4 bytes	2 registers
Underflow	0x9000	0x0A	4 bytes	2 registers
Overflow	0x9000	0x0C	4 bytes	2 registers

9.2.4. Module type query

Function codes	Base address	Max. offset address	Operation type	Function
03	0x9500	0x0064	Word reading	Read holding register

9.2.4.1. Module Type (ID) Description

Module ID query: Function code: 0x03; Access address: base address (0x9500) +offset address. Suggest querying with a length of 4 bytes.

Note: The access address for reading all module IDs is 0x9500, with 64 registers.

Module order	Base address	Offset address	Length	Description
1	0x9500	0x00	4 bytes	2 registers
2	0x9500	0x02	4 bytes	2 registers
3	0x9500	0x04	4 bytes	2 registers
4	0x9500	0x06	4 bytes	2 registers
5	0x9500	0x08	4 bytes	2 registers
N	0x9500	(N-1) *2	4 bytes	2 registers
32	0x9500	0x3E	4 bytes	2 registers

9.2.4.2. Module Model and ID Comparison Table

Module	ID	Description
FX20-DI-BF60	0x00010100	8 DI PNP/NPN universal input module
FX20-DI-BH60	0x00020200	16 DI PNP/NPN universal input module
FX20-DI-BL60	0x00070400	32 DI PNP/NPN universal input module
FX20-DO-BF00	0x10010001	8 DO module (PNP)
FX20-DO-BF50	0x10020001	8 DO digital output module (NPN)
FX20-DO-RF00	0x10100001	8-channel solid state relay module
FX20-DO-RF50	0x10120001	8-channel mechanical relay module
FX20-DO-BH00	0x10030002	16 DO module (PNP)

FX20-DO-BH50	0x10040002	16 DO module (NPN)
FX20-DO-BL00	0x10060004	32 DO module (PNP)
FX20-DO-BL50	0x10070004	32 DO module (NPN)
FX20-AI-BD60	0xA0010800	4-channel analog input module
FX20-AI-BF60	0xA0041000	8-channel analog input module
FX20-AI-BD80	0xC0010800	4-channel RTD input module
FX20-AI-BD90	0xC0020800	4-channel TC input module
FX20-AO-BD60	0xB0010008	4-channel analog output module
FX20-AO-BF60	0xB0040010	8-channel analog output module
FX20-CNT-BB00	0xD0011C14	2-channel CNT module
FX20-SCM-BB00	0x80013030	2-channel RS485/RS422/RS232 module
FX20-LKM-BD00	0xF0012620	4-channel IO-Link Master module
FX20-PGM-BA00	0x90020C0C	1-channel pulse output module

9.3. Configuration Test Example

This section demonstrates the usage of the FX20 distributed I/O ModbusTCP adapter through a simple configuration connection process.

The list of test product models is as follows:

Type	Model	Description
Bus adapter	FX20-GW-MT00	ModbusTCP
Digital input	FX20-DI-BF60	8DI, PNP/NPN
Digital output	FX20-DO-BH00	16DO, PNP
Analog input	FX2-AI-BD60	4AI, Current and voltage
Analog output	FX2-AO-BD60	4AO, Current and voltage

The above products are connected to the computer through Ethernet cables and have completed all power and communication connections. The FX20 adapter has a default IP address of 192.168.0.10, and the test computer's IP address is 192.168.0.100.

9.3.1. Perform module function testing on FX20 using MODBUS debugging assistant

Open Net Assist, select "TCP Client" for network protocol, fill in the default IP address of FX20 coupler as "192.168.0.10" for network host address, fill in "502" for remote host port, and click the "Connect" button to connect to the device. Click on the "Modbus Commands" tab and select the protocol type "ModbusTCP"; Select "HEX" hexadecimal data format for receiving and sending settings.

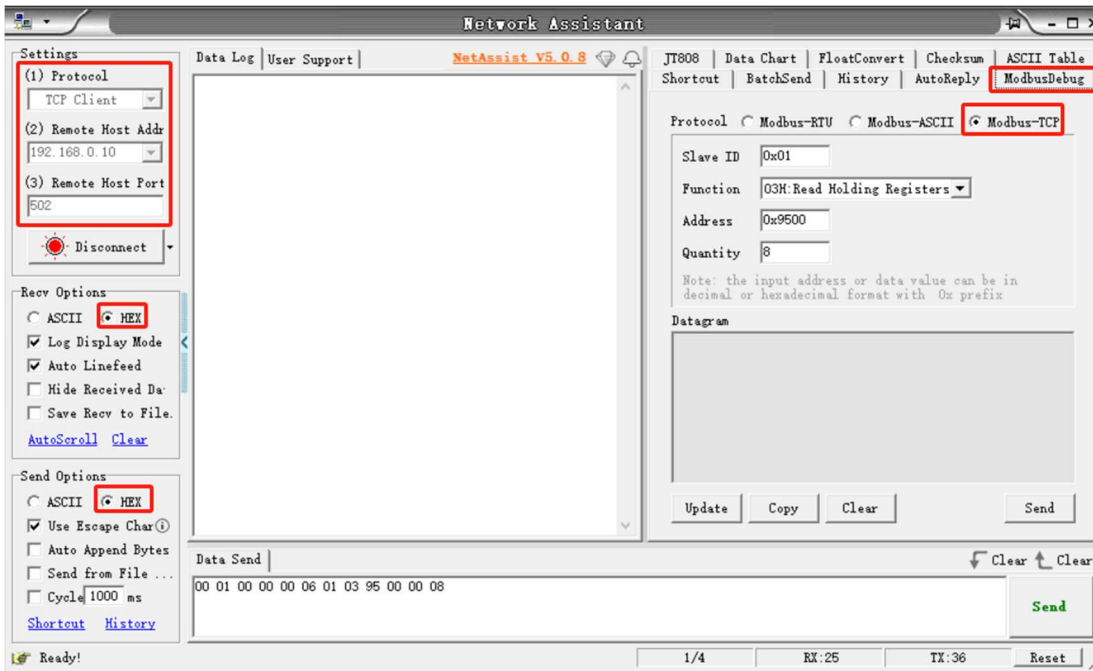

9.3.1.1. Module Type Reading

The FX20 ModbusTCP adapter supports module query function. By using the query command to obtain the module code, the actual connected module model can be obtained by querying the "9.2.4 Module Type Comparison Table". In this example, select the function code "03H: Read and Hold Register", register address "0x9500", and write the number of registers to "8", that is, read the module type information of 8 words in length. Click the "Send" button to receive the following information:

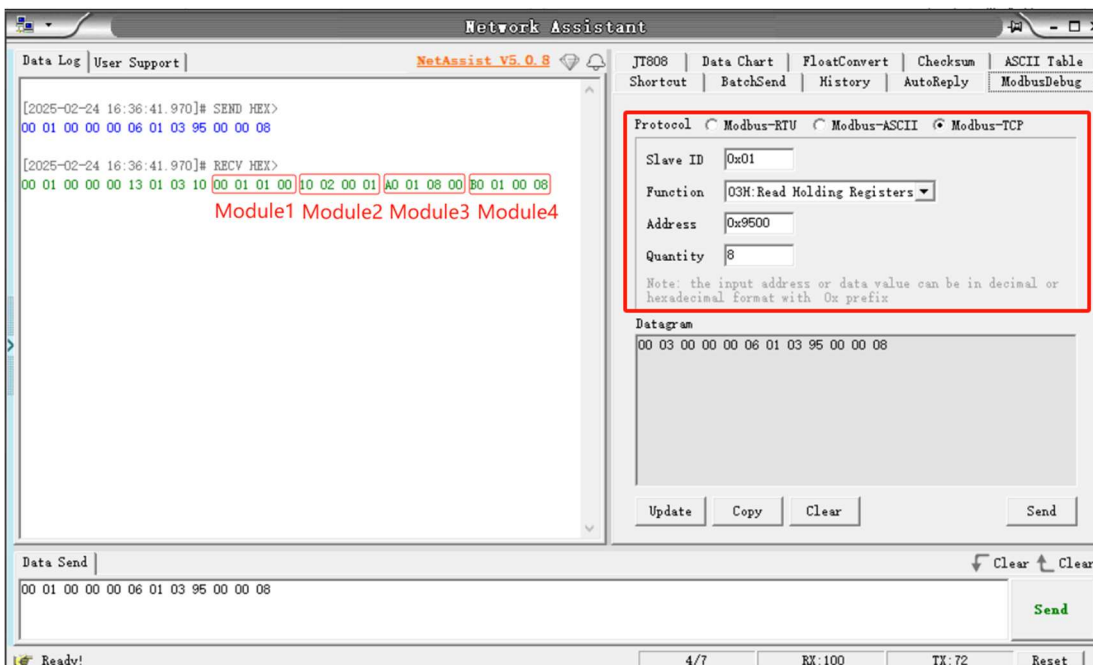

Module 1:00 01 00, Module 2: 10 02 00 01, Module 3: A0 01 08 00, Module 4: B0 01 00 08. According to the "9.2.4 Module Type Comparison Table", module 1 model is FX20-DI-BF60, module 2 model is FX20-DO-BF50, module 3 model is FX20-AI-BD60, and module 4 model is FX20-AO-BD60.

9.3.1.2. Digital I/O modules operation

a) Write Command Example

Assuming that it is necessary to provide output models for all channels of the 16 point DO module, the operation steps are as follows: on the Net Assist software operation interface, select the function code "Function Number Selection: 10H Write Multiple registers" and register address "0x1000" according to actual usage, write register data to "0xFF", click the send button to make all channels of the module output high level, and the indicator lights for all output channels of the module are green and constantly on.

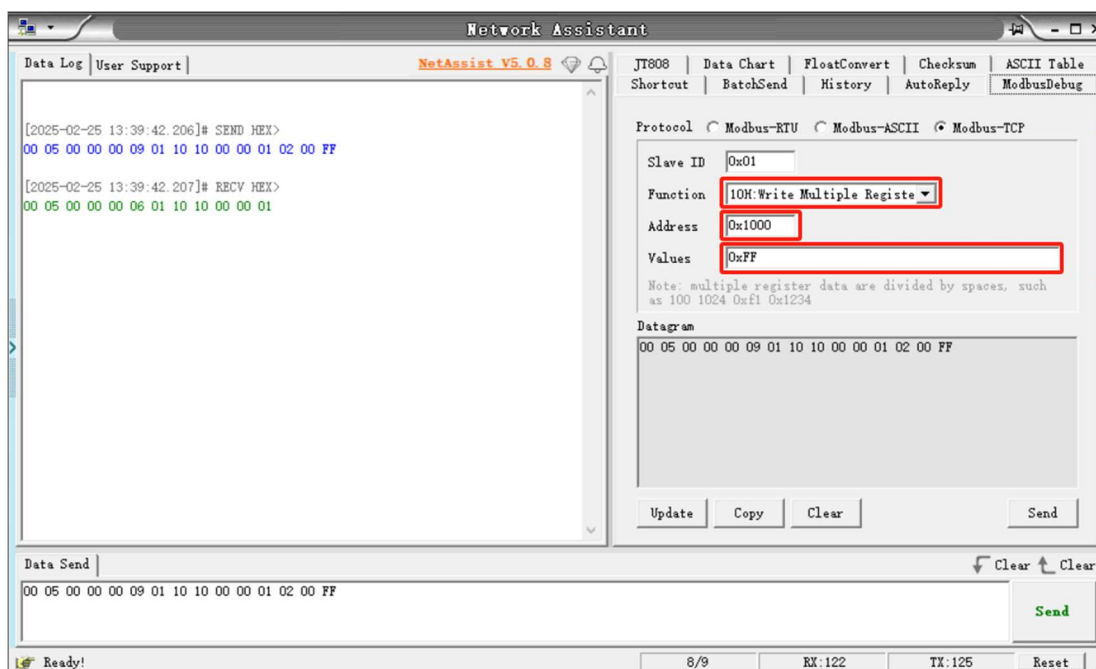

b) Read command example

Connect the digital output module one-to-one to the input module channel, and all channel indicator lights of the module will be constantly on. At this time, read the IO status of the FX20-DI-BF60 (8-point input) module, select the function code "03H: Read and hold register", register address "0x0000", and write the register quantity to "1", that is, read the IO status of one word length. The current device's IO value can be read in the message. Click the "Send" button, receive the message reply "FF", convert it into binary data "11111111", that is, all channels of the input module are "1".

9.3.2. Configure module parameters through web server

The FX20 web server can easily set parameters for the FX20 analog modules and function modules. The following will take the analog modules as an example to explain the operation.

- 9.3.2.1. Open a computer browser, enter the IP address of the FX20 ModbusTCP adapter in the address bar, press enter, and enter the FX20 web server homepage.



- 9.3.2.2. Click on Slot, Device List, you can see the modules information connected by the FX20 adapter.

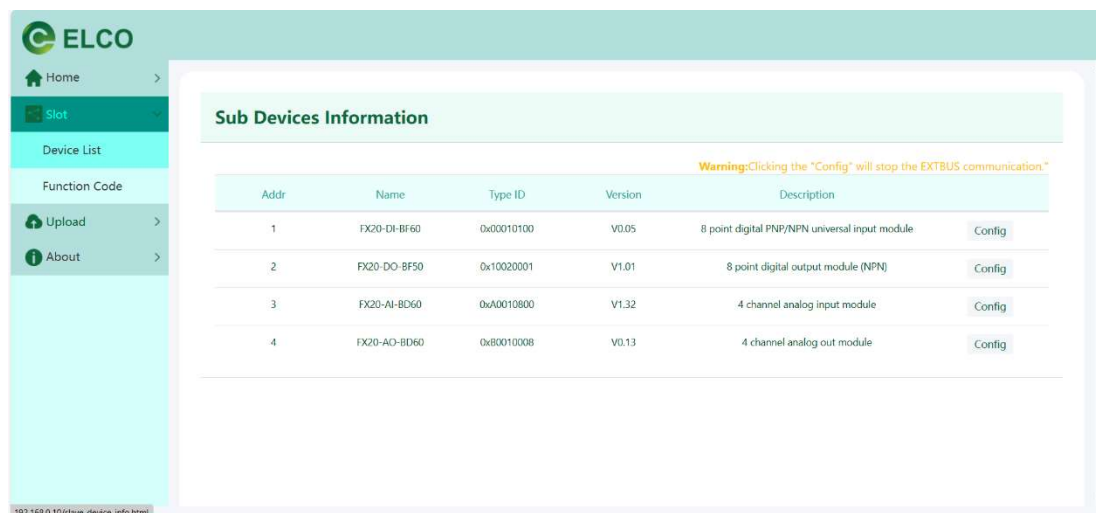

- 9.3.2.3. Click on the Config of the corresponding module to configure it. In this example, select the FX20-AI-BD60 4-channel analog input module for configuration. Click "Read" to view the current setting value, and click "Write" to confirm the selected setting item, as shown in the following figure.

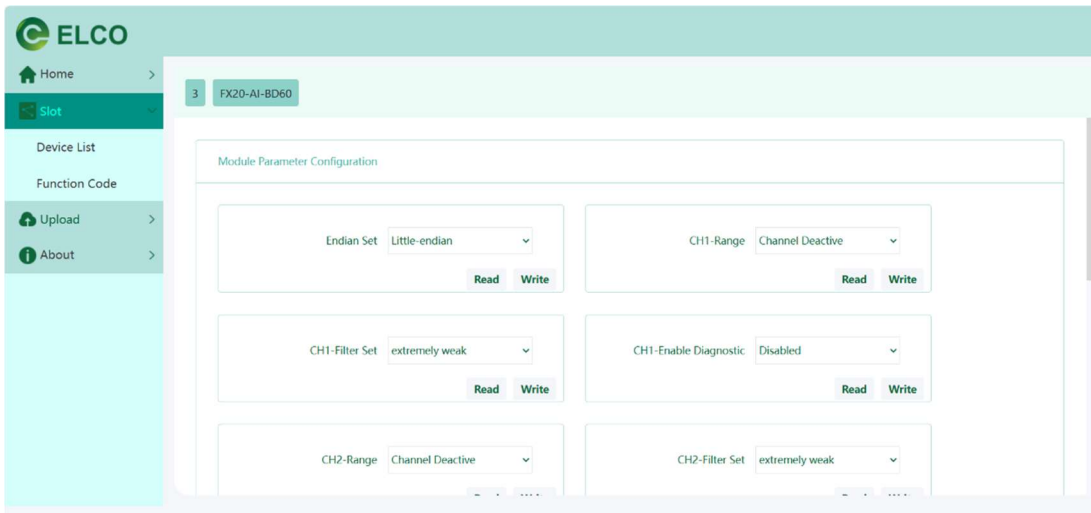

9.3.2.4. In the FX20-AI-BD60 4-channel analog input module config, the order of data byte high and low bits can be configured. It is necessary to decide whether to choose little endian (low byte is placed at the low address end of memory, high byte is placed at the high address end of memory) or big endian (high byte is placed at the low address end of memory, low byte is placed at the high address end of memory) based on the selected controller settings.



9.3.2.5. In the configuration of the FX20-AI-BD60 4-channel analog input module, the range of each channel can be set. By default, the channel is in a closed state, and the appropriate range needs to be selected according to the signal type.

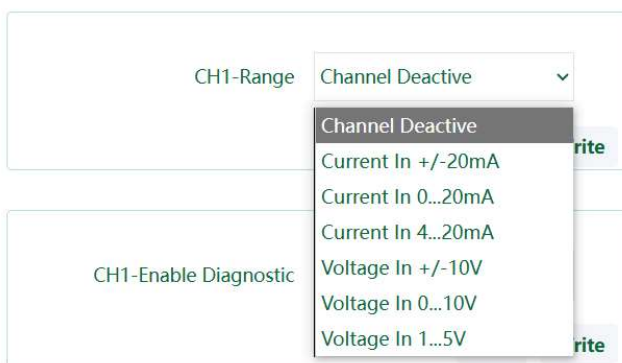

9.3.2.6. In the FX20-AI-BD60 4-channel analog input module config, the filtering time can also be set, which is divided into five levels: extremely weak, weak, medium, strong, and extremely strong.

9.3.2.7. FX20 module diagnostic upload option.

Disabled: Do not upload diagnostic information.

Enabled: Upload diagnostic information.

The other channel settings are similar to channel 1 and will not be repeated.

9.3.2.8. In the FX20-AO-BD60 4-channel analog output module, in addition to setting parameters such as output signal range, there is also a network interrupt output status setting function.

Set to 0: After network disconnection, the channel output value switches to 0;

Set to substitute value: Set the output value as a substitute value after network disconnection;

Hold the last value: Maintain the final output value after network disconnection;

Substitute value: If you choose Set to substitute value, you can enter the substitute value in the Substitute value column, with a value range of 0-65535.

9.3.2.9. Function code query

Click on the "Function Code" directory on the left to view information such as the type, number, and

applicable function codes of the I/O modules connected to FX20 ModbusTCP, which facilitates the integration of FX20 into your control system.

Configuration Info		Modules Num:4		Function Code: 0x01, 0x02, 0x03, 0x04, 0x05, 0x06, 0x0F, 0x10			
IO Type	DI(Input Bit)	DO(Output Bit)	AI(Input Word)	AO(Output Word)	DI(Input Word)	DO(Output Word)	
Base Address(HEX)	0x4000	0x5000	0x2000	0x3000	0x0000	0x1000	
Index	Module Name	Function: 0x02	Function: 0x05 0x0F 0x01(R)	Function: 0x03 0x04	Function: 0x06 0x10 0x03(R)	Function: 0x03	Function: 0x06 0x10 0x03(R)
1	FX20-DI-BF60	0-7				0	
2	FX20-DO-BF50		0-7				0-0
3	FX20-AI-BD60			0-3			
4	FX20-AO-BD60				0-3		

9.3.2.10. Upload upgrade function

FX20 supports firmware upgrade operations through web servers. By importing upgrade files, firmware upgrades can be performed on FX20 couplers and I/O modules. Specific methods are attached separately.

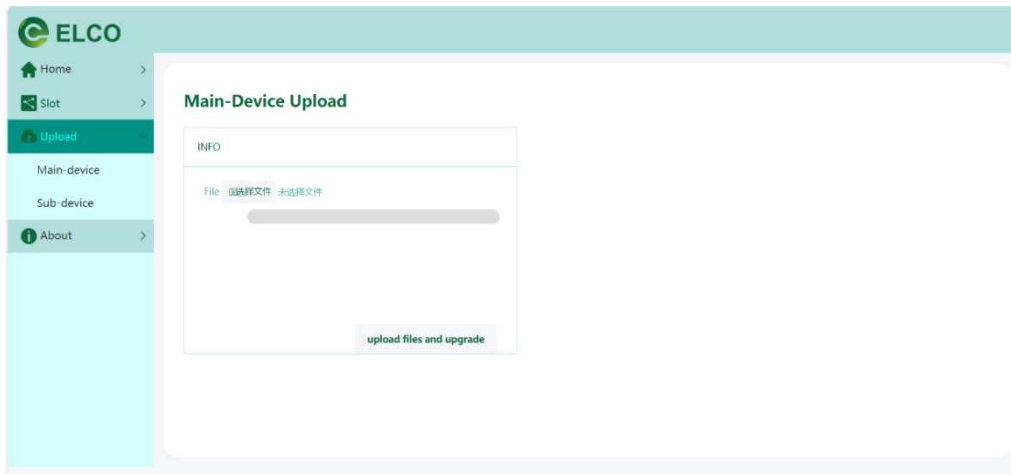

Note:

1. Do not attempt to upgrade on your own unless necessary;
2. The upgrade file must be provided by the official ELCO company;
3. Do not power off during the upgrade process;
4. After the upgrade is completed, the FX20 power supply needs to be restarted.

9.4. Representation of analog module values

The PLC processes analog values in binary format. The FX20 analog input module converts analog process signals into digital format, and the analog output module converts digital output values into analog signals.

Digital analog values are applicable to input and output values within the same rated range. Each analog signal occupies PLC address of 1 word, which means each analog signal corresponds to a 16bit value. The symbol of the analog value is always set at the highest bit 15: 0 represents positive and 1 represents negative. For analog modules with a resolution less than 16 bits, analog values are stored in a left aligned manner, and the unused least significant bits are filled with 0. For example, the analog value 18035 can be represented as the following binary value:

Bits	15	14	13	12	11	10	9	8	7	6	5	4	3	2	1	0
16bit	0	1	0	0	0	1	1	0	0	1	1	1	0	0	1	1
14bit	0	1	0	0	0	1	1	0	0	1	1	1	0	0	0	0

Analog signal types can be divided into bipolar and unipolar, with a current bipolar value of ± 20mA (input only) and a voltage bipolar value of ± 10 V, the current unipolarity values are 0-20mA and 4-20mA, and the voltage unipolarity values are 1-5 V and 0-10 V.

The thermal resistor supports 2-wire and 3-wire PT100/1000, and the thermocouple can support multiple TC types (internal compensation) such as J, K, T, N, E, etc.

9.4.1. Analog value input and output range of bipolar current

System value		Current input/output range		
	Decimalism	Hexadecimal	±20 mA	
118.515%	32767	7FFF	≥ 23.7 mA	Overflow, locking max. value
	27649	6C01		Overshoot range
100%	27648	6C00	20 mA	Rated range
75%	20736	5100	15 mA	
0.00362%	1	1	723.4 nA	
0%	0	0	0 mA	
	-1	FFFF	-723.4 nA	
-75%	-20736	AF00	-15 mA	
-100%	-27648	9400	-20 mA	
	-27649	93FF		Overshoot range
-118.519%	-32768	8000	≤ -23.7 mA	Underflow, locking min. value

9.4.2. Analog value input and output range of bipolar voltage

System value		Current input/output range		
	Decimalism	Hexadecimal	± 10V	
	32767	7FFF	> 10.24 V	Overflow, locking max. value
102.4%	28310	6E96	10.24 V	Overshoot range

	27649	6C01		Rated range
100%	27648	6C00	10 V	
75%	20736	5100	7.5 V	
0.00362%	1	1	361.7 μ V	
0%	0	0	0 V	
	-1	FFFF	-361.7 μ V	
-75%	-20736	AF00	-7.5 V	
-100%	-27648	9400	-10 V	
	-27649	93FF		Overshoot range
-102.4%	-28310	916A	-10.24 V	Underflow, locking min. value
	-32768	8000	< -10.24V	

9.4.3. Analog value input and output range of unipolar current

System value	Current input/output range				
	Decimalism	Hexadecimal	0~20mA	4~20mA	
118.515%	32767	7FFF	≥ 23.7 mA	≥ 22.96 mA	Overflow, locking max. value
	27649	6C01			Overshoot range
100%	27648	6C00	20 mA	20 mA	Rated range
75%	20736	5100	15 mA	16 mA	
0.00362%	1	1	723.4 nA	4mA+578.7nA	
0%	0	0	0 mA	4 mA	
-0.00362%	-1	FFFF			Overshoot range
-17.59%	-4864	ED00	-3.52 mA	1.185 mA	
	-32768	8000	<-3.52 mA	< 1.185 mA	Underflow, locking min. value

9.4.4. Analog value input and output range of unipolar voltage

System value	Current input/output range				
	Decimalism	Hexadecimal	1~5 V	0~10 V	
	32767	7FFF	> 5.7 V	> 10.24 V	Overflow, locking max. value
118.515%	32767	7FFF	5.7 V		Overshoot range
102.4%	28310	6E96		10.24 V	
100%	27648	6C00	5 V	10 V	Rated range

75%	20736	5100	4 V	7.5 V	
0.00362%	1	1	1V+144.7 μV	361.7 μV	
0%	0	0	1 V	0 V	
	-1	FFFF			Overshoot range
-17.59%	-4864	ED00		-1.759 V	
-25%	-6912	E500	0 V		
	-32768	8000	< 0 V	< -1.759 V	Underflow, locking min. value

9.4.5. Analog value measurement range of PT x00 standard thermal resistance

System value		Current input range	
Decimalism	Hexadecimal	-200~+850 °C	
32767	7FFF	≥ 850.1 °C	
8500	2134	850 °C	
6375	18E7	637.5 °C	
10	A	1 °C	
0	0	0 °C	
-10	FFF6	-1 °C	
-1500	FA24	-150 °C	
-2000	F830	-200 °C	
-32768	8000	≤ -200.1 °C	
		Underflow, locking min. value	

9.4.6. Representation of simulated values within the measurement range of thermocouples

For J, K, T, N, and E type thermocouples, determine the rated input and output range based on the temperature range of the graduation table. Divide the decimalism value of the system by 10 to obtain the current temperature, with a resolution of 0.1 °C, and lock max. or min. value when exceeding the limit.

10. Fault diagnosis

Name	Status	Meaning	Recommended treatment
Adapter indicator			
PWR	Green	Normal	None
	Off	Power abnormal	1. Check if the polarity of the power wiring is correct; 2. Check if the power supply voltage is normal; 3. Adapter failure, replace;
BF	Green	Normal	None
	Red	Communication abnormal	1. Check if the network cable is connected reliably; 2. Check for configuration errors; 3. Adapter failure, replace.
SF	Green	Normal	None
	Red	Error occurred	1. Check if there is a short circuit or overload in the IO module; 2. Adapter or IO module faulty, replace it.
STA	Green	Normal	None
	Red	Backplane communication error	1. Check if the backplane connection between modules is reliable; 2. Attempt to power off and restart the FX20 system again.
Digital I/O indicators			
PW	Green	Normal	None
	Off	24 V power supply abnormal	1. Check if the 24 V wiring of the IO module is correct; 2. Check if the 24 V power supply voltage of the IO module is normal; 3. IO module damaged, replace it.
MD	Green	Normal	None
	Green blinking	Connected but not configured	Check if the modules are configured correctly;
	Green and red blinking	Backplane communication abnormal;	1. Check if the connections between modules are reliable; 2. Restart FX20 system power supply; 3. IO Module malfunction, replace it.
	Red	Module error	1. Check if the IO module is configured correctly; 2. Check if there is a short circuit or overload in the IO module; 3. IO module damaged, replace it.
00-07,10-17	Green	Signal "1"	None
20-27,30-37	Off	Signal "0"	None
Analog I/O indicators			
PW	Green	Normal	
	Off	24V power supply abnormal	1. Check if the 24V wiring of the IO module is correct; 2. Check if the 24V power supply voltage of the IO module

			is normal; 3. IO module damaged, replace.
MD	Green	Normal	None
	Green blinking	Connected but not configured	Check if the modules are configured correctly;
	Green and red blinking	Backplane communication abnormal;	1.Check if the connections between modules are reliable; 2. Restart FX20 system power supply; 3. IO Module malfunction, replace it.
	Red	Module error	1.Check if the I/O module is configured correctly; 2.Check if there is a short circuit or overload in the IO module; 3. The analog channel value exceeds the range; 4.I/O module damaged, replace.
C1-C4	Off	Normal	None
C1-C8	Red	Channel over range	Check the analog input output signal range
Auxiliary power supply module indicators			
PW	Green	Normal	None
	Red	24V overvoltage or undervoltage	Check if the input 24V power supply voltage is normal;
Us	Green	Normal	None
	Off	No backplane 5V power supply	1. Check if the backplane connection between modules is reliable; 2. Power module damaged, replace.