

## FX20 series Modular I/O System EtherCAT Manual



**EtherCAT** 

## Content

<b>1. Product introduction</b>	3
<b>2. Version change record</b>	3
<b>3. About obtaining manuals</b>	3
<b>4. Warranty statement</b>	3
<b>5. Precautions</b>	4
5.1. Safety statement	4
5.2. Definition of safety level	4
5.3. Safety and tips	4
6.1. Appearance and function of EtherCAT bus adapter	7
6.2. FX20 bus adapter technical data	8
6.3. Profile drawing	9
6.4. Introduction to the appearance of I/O modules	9
6.4.1. 8-channel digital input/output module	9
6.4.2. 16-channel digital input output module	18
6.4.3. 32-channel digital input output module	23
6.4.4. 4-channel analog input/output module	28
<b>7. Mechanical installation and disassembly</b>	43
7.1. Installation location and minimum installation distance	43
7.2. FX20 adapter installation	43
7.3. I/O modules installation	43
7.4. Modules disassembly	44
<b>8. Electrical installation and wiring</b>	46
8.1. Cable specification	46
8.1.1. Communication cable	46
8.1.2. Power and signal cables	46
8.2. Modules wiring diagram	47
8.2.1. FX20 system power supply diagram	47
8.2.2. EtherCAT bus adapter wiring diagram	49
8.2.3. 8-channel DI module wiring diagram and I/O mapping	49
8.2.4. 8-channel DO PNP module wiring diagram and I/O mapping	50
8.2.5. 8-channel DO NPN module wiring diagram and I/O mapping	50
8.2.6. 4-channel SSR (AC) output module wiring diagram I/O mapping	51
8.2.7. 8-channel relay output module wiring diagram and I/O mapping	51
8.2.8. 16-channel DI module wiring diagram and I/O mapping	52
8.2.9. 16-channel DO PNP module wiring diagram and I/O mapping	52
8.2.10. 16-channel DO NPN module wiring diagram and I/O mapping	53
8.2.11. 32-channel DI module wiring diagram and I/O mapping	54
8.2.12. 32-channel DO PNP module wiring diagram and I/O mapping	55
8.2.13. 32-channel DO NPN module wiring diagram and I/O mapping	56

- 8.2.14. 4-channel AI module wiring diagram and I/O mapping.....57
- 8.2.15. 4-channel AO module wiring diagram and I/O mapping.....57
- 8.2.16. 8-channel AI module wiring diagram and I/O mapping.....58
- 8.2.17. 8-channel AO module wiring diagram and I/O mapping.....59
- 8.2.18. 4-channel RTD module wiring diagram and I/O mapping .....60
- 8.2.19. 4-channel TC module wiring diagram and I/O mapping.....60
- 8.2.20. Auxiliary power module wiring diagram.....61
- 9. Configuration and test .....62**
  - 9.1. ESI file .....62
  - 9.2. FX20 EtherCAT bus adapter I/O mapping .....62
  - 9.3. FX20 Configuration Examples .....63
    - 9.3.1. Configuration steps in Omron Sysmac Studio.....63
    - 9.3.2. Configuration steps in CODESYS.....70
  - 9.4. Representation of analog module values .....76
    - 9.4.1. Analog value input and output range of bipolar current.....76
    - 9.4.2. Analog value input and output range of bipolar voltage.....76
    - 9.4.3. Analog value input and output range of unipolar current.....77
    - 9.4.4. Analog value input and output range of unipolar voltage.....77
    - 9.4.5. Analog value measurement range of PT x00 standard thermal resistance .....78
    - 9.4.6. Representation of simulated values within the measurement range of thermocouples.....78
- 10. Fault diagnosis.....79**

## 1. Product introduction

The FX20 series modular I/O system is a new generation IP20 expandable I/O product launched by Elco. It's composed of bus adapters, I/O modules and functional modules, with the min. module width of only 15 mm, which is thin and compact, greatly saving space inside the control cabinet. The wiring terminal is designed with two separate sections, which facilitates module replacement and maintenance. Keeping the fresh family color scheme, it provides practical tool-free spring terminals for fast and convenient wiring. The terminal buttons are identified by color, and different colors represent different functions, improving the efficiency of wiring and checking to the most.

FX20 adopts high-speed backplane bus technology, with high communication bandwidth and fast response speed, which can meet the application of high-speed production takt. By simply replacing the bus coupler, different automation bus systems can be connected. Currently, it is mainly compatible with mainstream Ethernet bus protocols such as EtherCAT, PROFINET, EtherNet/IP, CC-Link IE Field Basic, and can expand up to 32 functional modules.

FX20 has a wide range of functional modules with powerful functions, including digital input and output, relay output, analog input and output, temperature measurement, high-speed counting, IO-Link master station, communication bridge, etc. It can meet the needs of various automation systems and is widely used in industries such as automobile manufacturing, parts processing, 3C electronics, lithium battery equipment, photovoltaic, logistics, printing and packaging.

This manual mainly introduces the mechanical installation, electrical installation, and module configuration examples of FX20 products.

## 2. Version change record

Revision date	Version	Content changed
2023-8	V1.0	1st Version
2023-11	V1.1	Add I/O models
2023-12	V1.2	Modified parameters
2024-05	V1.3	Content Updated
2025-02	V1.4	Wiring diagram updated
2025-06	V1.5	Configuration case updated
2025-12	V2.0	Update fonts and layouts

## 3. About obtaining manuals

This manual is not shipped with the product. You can obtain its PDF file through the following methods:

- Log in to Elco's official website ([www.elcoautomation.com](http://www.elcoautomation.com)), search for keywords, and download.
- Use WeChat to search and subscribe the official account of "Elco Automation" to obtain the product manual.
- Contact Elco sales engineers in your area to obtain the latest manual materials.

## 4. Warranty statement

Under normal use, if the product malfunctions or is damaged, Elco will be responsible for an 18 months warranty (from and subject to the delivery date; executed according to the agreement, if there is a contract). When it's over 18 months, maintenance fees will be charged.

- Within 18 months, repair fees will be charged for product damaged by the following circumstances.
- Failure to operate according to the manual

- Fires, floods, and abnormal voltage
- Used for abnormal functions
- Beyond the application scope
- Force majeure (natural disasters, earthquakes, lightning strikes).

The service fees shall be calculated according to Elco's unified standards. Subject to the contract, if there is.

## 5. Precautions

### 5.1. Safety statement

- 1) Please read and follow these precautions before installing, operating, and maintaining the product.
- 2) To ensure personal and equipment safety, please follow all precautions indicated on the product and in the manual when installing, operating, and maintaining the product.
- 3) The 'caution', 'warning' and 'danger' items in the manual do not represent all precautions that should be followed, but only serve as supplements to all safety precautions.
- 4) This product should be used in an environment that meets the design specifications, otherwise it may cause malfunctions. Functional abnormalities or component damage caused by non-compliance with relevant regulations are not within the scope of product quality assurance.
- 5) Elco will not bear any legal responsibility for personal safety accidents, property losses, etc. caused by mishandling of products.

### 5.2. Definition of safety level

<b>Caution</b>	If not operated properly, it may result in minor body injury or equipment damage
<b>Warning</b>	If not operated properly, it may result in death or serious bodily injury.
<b>Danger</b>	If not operated properly, it will result in death or serious bodily injury.

### 5.3. Safety and tips

	Reminding		Please refer to the relevant manual content before operation
	Risk of electrical shock		Information tips
	General tips		Only authorized electrical personnel can operate
	Earthing		Only authorized mechanical personnel can operate

## When designing control systems

### Dangerous!

- Please be sure to design a safety circuit to ensure that the control system can still work safely in the event of external power failure or PLC failure;
- When long time overcurrent caused by exceeding rated load current or short circuit, the module may smoke or catch fire. So, safety devices such as fuses or circuit breakers need to be installed.

## When installing

### Warning!

- Only professional maintenance personnel who have been trained on electrical equipment and have sufficient electrical knowledge can install this product.

### **Dangerous!**

- During the operation, all external power supplies used by the system must be disconnected. If the power supply is not fully disconnected, it may cause electric shock, module failure or malfunction.
- Do not use programmable controller in the following conditions: places with dust, oil fumes, conductive dust, corrosive gases, and flammable gas.
- Exposed to high temperatures, condensation, and wind and rain; In situations with vibration and impact. Electric shock, fire, and mis-operation can also cause product damage and deterioration.
- The programmable controller is an Open type device, please install it in a control cabinet with a lock (the IP rating of the control cabinet housing > IP20). Only operators who have been trained on electrical equipment and have sufficient electrical knowledge can open the control cabinet.
- During installation, avoid metal shavings and wire ends falling into the ventilation hole of the controller, which may cause fire, malfunction, and mis-operation.

### **Caution!**

- After installation, ensure that there are no foreign objects on the ventilation surface, otherwise it may cause poor heat dissipation, fire, malfunction, and mis-operation.
- When installing, it needs to be tightly connected to connectors and the module connection hooks need to be securely locked. If the module is installed improperly, it may cause mis-operation, malfunction, and detachment.

## When wiring

### **Dangerous!**

- Only professional maintenance personnel who have been trained on electrical equipment and have sufficient electrical knowledge can carry out the wiring of this product;
- During the operation, all external power supplies used by the system must be disconnected. If the power supply is not fully disconnected, it may cause electric shock, module failure or malfunction.

### **Dangerous!**

- Cable terminals should be well insulated to ensure that the insulation distance between cables does not decrease after installation on the terminal block. Otherwise, it may cause electric shock or equipment damage.
- To avoid electric shock, please cut off the power supply before connecting to the power supply of this product;
- The input power specifications of this product can be found in technical specifications. Please provide the power supply strictly in accordance with the data in the technical specifications. If the power supply is not within the required range, it will seriously damage this product. Therefore, please regularly check whether the DC power supply provided by the switching power supply is stable.

## During operation and maintenance

### **Caution!**

- Only professional maintenance personnel who have been trained on electrical equipment and have sufficient electrical knowledge can carry out the maintenance.
- Do not touch the terminals when powered on, otherwise it may cause electric shock or malfunction.
- During the operation, all external power supplies used by the system must be disconnected. If the power supply is not fully disconnected, it may cause electric shock or malfunction.
- At locations where operators directly come into contact with mechanical parts, such as loading and unloading mechanical tools, or where machinery operates automatically, careful consideration must be given to the function of on-site manual devices or other backup means. It needs to be independent of programmable controllers and can start or interrupt the automatic operation of the system.
- If the program needs to be modified while the system is running, it is necessary to consider using locks or other protective measures to ensure that only authorized personnel can make necessary modifications.

### When Scrapping

#### Caution!

- Please treat it as industrial waste;
- Scrapped equipment and products need to be disposed of and recycled according to industrial waste treatment standards to avoid environmental pollution.

**Please keep the content of this safety precautions properly for future reference, and be sure to hand over this manual to the end user.**

## 6. FX20 Product Introduction

### 6.1. Appearance and function of EtherCAT bus adapter

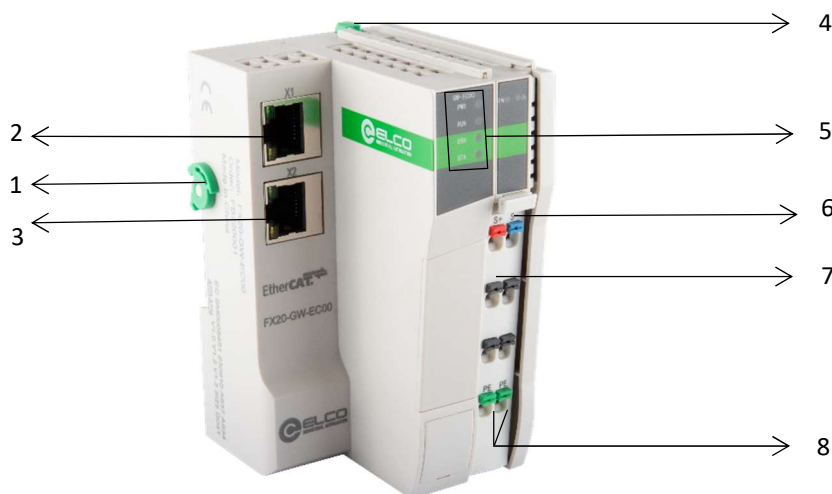

Item	Name	Function	Status
1	Rail locking device	Lock bus adapter module	Assembling completed: locking position Disassembling module: unlocking position
2	EtherCAT IN	EtherCAT input interface	-
3	EtherCAT OUT	EtherCAT output interface	-
4	Module fixing device	Fixing module and rail	Disassembling module: pull out Assembling completed: press down
5	Coupler running indicators		
	PWR	Indicate power supply	Green: normal Off: abnormal
	RUN	Indicate running status	Green: normal Flashing: Pre-OP status Off: system doesn't run
	ERR	Report system error	Green: normal Red: error
	STA	Indicate backplane communication status	Green: normal Red: backplane communication error
6	Power input terminal 0 V	0 V access	
7	Power input terminal 24 V+	24 VDC access	
8	PE	System grounding	

## 6.2. FX20 bus adapter technical data

### FX20-GW-EC00

#### ARTICLE PROPERTIES

<b>PRODUCT TYPE</b>	FX20 series modular I/O system EtherCAT adapter	<b>PRODUCT GROUP</b>	IP20 modular I/O system
<b>DESCRIPTION</b>	Gateway module for EtherCAT, 2 x RJ45, max. 32 cascable modules, 24 V DC, IP20, DIN rail installation, overcurrent / reverse polarity / surge protection	<b>PU</b>	1 pc
		<b>COUNTRY OF ORIGIN</b>	CN

#### TECHNICAL DATA

<b>COMMUNICATION PROTOCOL</b>	EtherCAT	<b>SUPPLY VOLTAGE (SYSTEM)</b>	24 V DC (± 20 %)
<b>TRANSMISSION MEDIUM</b>	Shielded twisted pair S/FTP, F/FTP or SF/FTP, 100 Ω, Cat. 5	<b>INPUT CURRENT (TYP.) AT NOMINAL LOAD (24 V)</b>	200 mA
<b>TRANSMISSION RATE</b>	100 Mbit/s	<b>BACKPLANE POWER SUPPLY VOLTAGE</b>	5 V DC
<b>BUS SEGMENT LENGTH (MAX.)</b>	100 m	<b>BACKPLANE POWER SUPPLY CURRENT (MAX.)</b>	3 A
<b>BUS NODE ADDRESS RANGE</b>	Address allocation by PLC	<b>ELECTRICAL ISOLATION</b>	500 V (power supply and bus)
<b>NUMBER OF MODULES PER NODE (MAX.)</b>	32	<b>POWER PROTECTION</b>	Overcurrent protection, reverse polarity protection, surge protection
<b>INPUT AND OUTPUT PROCESS MAPPING (MAX.)</b>	512 bytes / 512 bytes	<b>FAULT DIAGNOSIS METHOD</b>	LED, communication message

#### CONNECTION DATA

<b>WIRE CONNECTION</b>	Plug-in terminal block	<b>STRIPPED LENGTHS</b>	8 ... 10 mm 0.315 ... 0.394 in
<b>CROSS SECTION</b>	0.08 mm <sup>2</sup> ... 2.5 mm <sup>2</sup> AWG 28 ... 14		

#### ENVIRONMENTAL REQUIREMENTS

<b>PROTECTION CLASS</b>	IP20	<b>ELECTRICAL FAST TRANSIENT (EFT)</b>	Level A, per IEC 61000-4-4
<b>MOUNTING TYPE</b>	DIN-35 mm rail	<b>ELECTRO-STATIC DISCHARGE (ESD)</b>	Level A, per IEC 61000-4-2
<b>AMBIENT TEMPERATURE</b>	-5 ... +60 °C	<b>SURGE TEST</b>	Level A, per IEC 61000-4-5

<b>STORAGE TEMPERATURE</b>	-25 ... +70 °C	<b>VIBRATION RESISTANCE</b>	4 g, per IEC 60068-2-6
<b>RELATIVE HUMIDITY</b>	95%, non-condensing	<b>SHOCK RESISTANCE</b>	15 g, per IEC 60068-2-27
<b>OPERATING ALTITUDE</b>	0 ... 2000 m / 0 ... 6562 ft	<b>EU ROHS COMPLIANCE STATUS</b>	Yes
<b>POLLUTION DEGREE</b>	2, per IEC 61131-2	<b>MATERIAL COMPLIANCE</b>	Compliant with REACH

**GENERAL DATA**

<b>HOUSING MATERIAL</b>	PPE	<b>DIMENSIONS (H X W X D)</b>	110.4 x 57 x 78.5 mm
<b>WEIGHT</b>	230 g	<b>MTTF (25 °C)</b>	111 years
<b>COLOR</b>	Light gray	<b>APPROVALS</b>	CE

**6.3. Profile drawing**

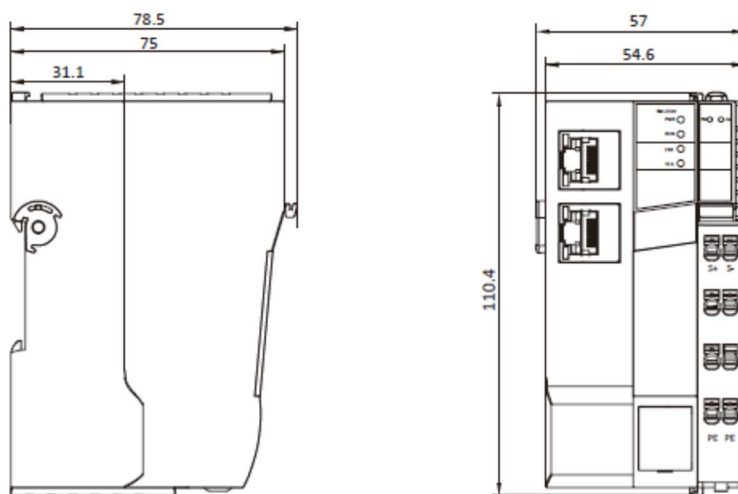

**6.4. Introduction to the appearance of I/O modules**

**6.4.1. 8-channel digital input/output module**

**6.4.1.1. 8-channel digital input module**

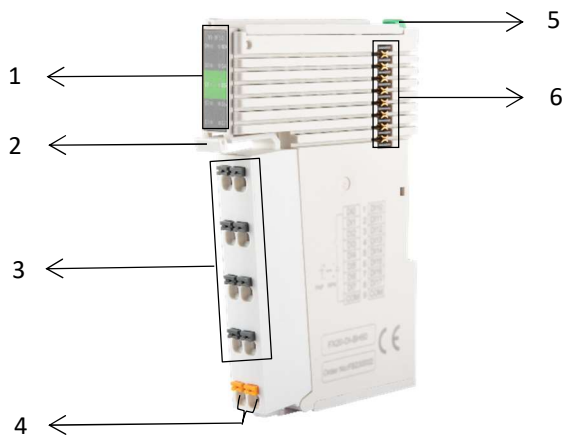

Item	Name	Function	Status
1	Module running indicators		
	PW	Backplane power indicator	Green: normal; Red: I/O power supply abnormal; Off: no backplane power
	MD	Module error indicator	Green: normal Red: Module channel error Green blinking: Connected but not configured; Red and green blinking: Backplane communication abnormal;
	00-07	Input signal indicator	Green: input "1" Off: input "0"
2	Terminal disassembly device	Press the device to separate the terminal block from the module	-
3	IO input terminal 0-7	IO signal wiring	-
4	Common ground terminal	IO signal Common ground terminal	0 V when the input signal is PNP, 24 V+ when the input signal is NPN
5	Module fixing device	Used to fix the module to the standard mounting rail	Pulling up: assembling position; Pressing down: locking position
6	Backplane bus interface	Backplane communication among modules	-

6.4.1.2. 8-channel digital input module technical data

FX20-DI-BF60

ARTICLE PROPERTIES

<b>PRODUCT TYPE</b>	FX20 series modular I/O system digital input modules	<b>PRODUCT GROUP</b>	IP20 modular I/O system
<b>DESCRIPTION</b>	FX20-submodule 8-channel input PNP / NPN, 24 V DC, IP20, DIN rail installation	<b>PU</b>	1 pc
		<b>COUNTRY OF ORIGIN</b>	CN

TECHNICAL DATA

<b>NUMBER OF DIGITAL INPUTS</b>	8	<b>INPUT FILTERING DELAY</b>	0 ms, 1 ms, 3 ms and 10 ms can be configured
<b>INPUT TYPE</b>	PNP / NPN	<b>CURRENT CONSUMPTION (5 V)</b>	60 mA
<b>INPUT SIGNAL '0'</b>	0 ... 5 V DC	<b>PROCESS DATA LENGTH</b>	1 byte
<b>INPUT SIGNAL '1'</b>	18 ... 30 V DC	<b>FAULT DIAGNOSIS METHOD</b>	LED, communication message

**INPUT CURRENT PER CHANNEL FOR SIGNAL '1'** Typ. 4 mA

CONNECTION DATA

<b>WIRE CONNECTION</b>	Plug-in terminal block	<b>STRIPPED LENGTHS</b>	8 ... 10 mm 0.315 ... 0.394 in
<b>CROSS SECTION</b>	0.08 mm <sup>2</sup> ... 2.5 mm <sup>2</sup> AWG 28 ... 14		

ENVIRONMENTAL REQUIREMENTS

<b>PROTECTION CLASS</b>	IP20	<b>ELECTRICAL FAST TRANSIENT (EFT)</b>	Level A, per IEC 61000-4-4
<b>MOUNTING TYPE</b>	DIN-35 mm rail	<b>ELECTRO-STATIC DISCHARGE (ESD)</b>	Level A, per IEC 61000-4-2
<b>AMBIENT TEMPERATURE</b>	-5 ... +60 °C	<b>SURGE TEST</b>	Level A, per IEC 61000-4-5
<b>STORAGE TEMPERATURE</b>	-25 ... +70 °C	<b>VIBRATION RESISTANCE</b>	4 g, per IEC 60068-2-6
<b>RELATIVE HUMIDITY</b>	95%, non-condensing	<b>SHOCK RESISTANCE</b>	15 g, per IEC 60068-2-27
<b>OPERATING ALTITUDE</b>	0 ... 2000 m / 0 ... 6562 ft	<b>EU ROHS COMPLIANCE STATUS</b>	Yes
<b>POLLUTION DEGREE</b>	2, per IEC 61131-2	<b>MATERIAL COMPLIANCE</b>	Compliant with REACH

GENERAL DATA

<b>HOUSING MATERIAL</b>	PPE	<b>DIMENSIONS (H X W X D)</b>	110.6 x 15 x 78.4 mm
<b>WEIGHT</b>	63 g	<b>MTTF (25 °C)</b>	155 years
<b>COLOR</b>	Light gray	<b>APPROVALS</b>	CE

6.4.1.3. 8-channel digital output modules

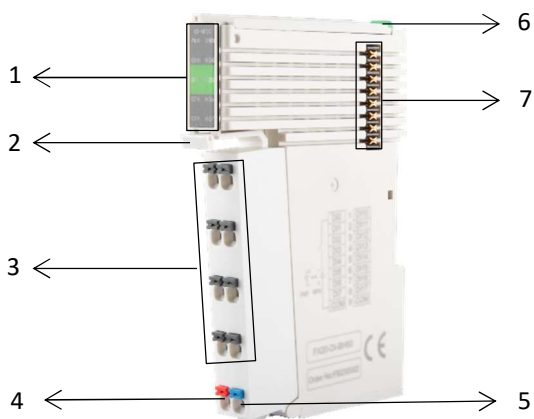

Item	Name	Function	Status
1	Module running indicators		
	PW	Backplane power indicator	Green: normal; Red: I/O power supply abnormal; Off: no backplane power
	MD	Module error indicator	Green: normal Red: Module channel error

			Green blinking: Connected but not configured; Red and green blinking: Backplane communication abnormal;
	00-07	Output signal indicator	Green: output "1" Off: output "0"
2	Terminal disassembly device	Press the device to separate the terminal block from the module	-
3	IO output terminal 0-7	IO signal wiring	-
4	24 V power terminal	24 V+	-
5	24 V power terminal	0 V	-
6	Module fixing device	Used to fix the module to the standard mounting rail	Pulling up: assembling position; Pressing down: locking position.
7	Backplane bus interface	Backplane communication	-

6.4.1.4. 8-channel digital output module technical data

FX20-DO-BF00

ARTICLE PROPERTIES

<b>PRODUCT TYPE</b>	FX20 series modular I/O system digital output modules	<b>PRODUCT GROUP</b>	IP20 modular I/O system
<b>DESCRIPTION</b>	FX20-submodule 8-channel output PNP, 24 V DC, 0.5 A, IP20, DIN rail installation	<b>PU</b>	1 pc
		<b>COUNTRY OF ORIGIN</b>	CN

TECHNICAL DATA

<b>NUMBER OF DIGITAL OUTPUTS</b>	8	<b>SWITCHING FREQUENCY</b>	Max. 1 kHz (Resistive loads) Max. 1 Hz (Inductive loads) Max. 10 Hz (Lamps)
<b>OUTPUT TYPE</b>	PNP	<b>OUTPUT HOLD</b>	Supports, configured by PLC or web server
<b>OUTPUT VOLTAGE</b>	24 V DC	<b>CURRENT CONSUMPTION (5 V)</b>	60 mA
<b>OUTPUT CURRENT</b>	Max. 0.5 A per channel, total 4 A per module	<b>PROCESS DATA LENGTH</b>	1 byte
<b>OUTPUT LOAD TYPES</b>	Resistive loads, inductive loads, lamps	<b>FAULT DIAGNOSIS METHOD</b>	LED, communication message

CONNECTION DATA

<b>WIRE CONNECTION</b>	Plug-in terminal block	<b>STRIPPED LENGTHS</b>	8 ... 10 mm 0.315 ... 0.394 in
<b>CROSS SECTION</b>	0.08 mm <sup>2</sup> ... 2.5 mm <sup>2</sup> AWG 28 ... 14		

ENVIRONMENTAL REQUIREMENTS

<b>PROTECTION CLASS</b>	IP20	<b>ELECTRICAL FAST TRANSIENT (EFT)</b>	Level A, per IEC 61000-4-4
<b>MOUNTING TYPE</b>	DIN-35 mm rail	<b>ELECTRO-STATIC DISCHARGE (ESD)</b>	Level A, per IEC 61000-4-2
<b>AMBIENT TEMPERATURE</b>	-5 ... +60 °C	<b>SURGE TEST</b>	Level A, per IEC 61000-4-5
<b>STORAGE TEMPERATURE</b>	-25 ... +70 °C	<b>VIBRATION RESISTANCE</b>	4 g, per IEC 60068-2-6
<b>RELATIVE HUMIDITY</b>	95%, non-condensing	<b>SHOCK RESISTANCE</b>	15 g, per IEC 60068-2-27
<b>OPERATING ALTITUDE</b>	0 ... 2000 m / 0 ... 6562 ft	<b>EU ROHS COMPLIANCE STATUS</b>	Yes
<b>POLLUTION DEGREE</b>	2, per IEC 61131-2	<b>MATERIAL COMPLIANCE</b>	Compliant with REACH

GENERAL DATA

<b>HOUSING MATERIAL</b>	PPE	<b>DIMENSIONS (H X W X D)</b>	110.6 x 15 x 78.4 mm
<b>WEIGHT</b>	63 g	<b>MTTF (25 °C)</b>	155 years
<b>COLOR</b>	Light gray	<b>APPROVALS</b>	CE

FX20-DO-BF50

ARTICLE PROPERTIES

<b>PRODUCT TYPE</b>	FX20 series modular I/O system digital output modules	<b>PRODUCT GROUP</b>	IP20 modular I/O system
<b>DESCRIPTION</b>	FX20-submodule 8-channel output NPN, 24 V DC, 0.5 A, IP20, DIN rail installation	<b>PU</b>	1 pc
		<b>COUNTRY OF ORIGIN</b>	CN

TECHNICAL DATA

<b>NUMBER OF DIGITAL OUTPUTS</b>	8	<b>SWITCHING FREQUENCY</b>	Max. 1 kHz (Resistive loads) Max. 1 Hz (Inductive loads) Max. 10 Hz (Lamps)
<b>OUTPUT TYPE</b>	NPN	<b>OUTPUT HOLD</b>	Supports, configured by PLC or web server
<b>OUTPUT VOLTAGE</b>	24 V DC	<b>CURRENT CONSUMPTION (5 V)</b>	60 mA
<b>OUTPUT CURRENT</b>	Max. 0.5 A per channel, total 4 A per module	<b>PROCESS DATA LENGTH</b>	1 byte
<b>OUTPUT LOAD TYPES</b>	Resistive loads, inductive loads, lamps	<b>FAULT DIAGNOSIS METHOD</b>	LED, communication message

CONNECTION DATA

<b>WIRE CONNECTION</b>	Plug-in terminal block	<b>STRIPPED LENGTHS</b>	8 ... 10 mm 0.315 ... 0.394 in
<b>CROSS SECTION</b>	0.08 mm <sup>2</sup> ... 2.5 mm <sup>2</sup> AWG 28 ... 14		

ENVIRONMENTAL REQUIREMENTS

<b>PROTECTION CLASS</b>	IP20	<b>ELECTRICAL FAST TRANSIENT (EFT)</b>	Level A, per IEC 61000-4-4
<b>MOUNTING TYPE</b>	DIN-35 mm rail	<b>ELECTRO-STATIC DISCHARGE (ESD)</b>	Level A, per IEC 61000-4-2
<b>AMBIENT TEMPERATURE</b>	-5 ... +60 °C	<b>SURGE TEST</b>	Level A, per IEC 61000-4-5
<b>STORAGE TEMPERATURE</b>	-25 ... +70 °C	<b>VIBRATION RESISTANCE</b>	4 g, per IEC 60068-2-6
<b>RELATIVE HUMIDITY</b>	95%, non-condensing	<b>SHOCK RESISTANCE</b>	15 g, per IEC 60068-2-27
<b>OPERATING ALTITUDE</b>	0 ... 2000 m / 0 ... 6562 ft	<b>EU ROHS COMPLIANCE STATUS</b>	Yes
<b>POLLUTION DEGREE</b>	2, per IEC 61131-2	<b>MATERIAL COMPLIANCE</b>	Compliant with REACH

GENERAL DATA

<b>HOUSING MATERIAL</b>	PPE	<b>DIMENSIONS (H X W X D)</b>	110.6 x 15 x 78.4 mm
<b>WEIGHT</b>	63 g	<b>MTTF (25 °C)</b>	155 years
<b>COLOR</b>	Light gray	<b>APPROVALS</b>	CE

6.4.1.5. 8-channel digital input/output module profile drawing

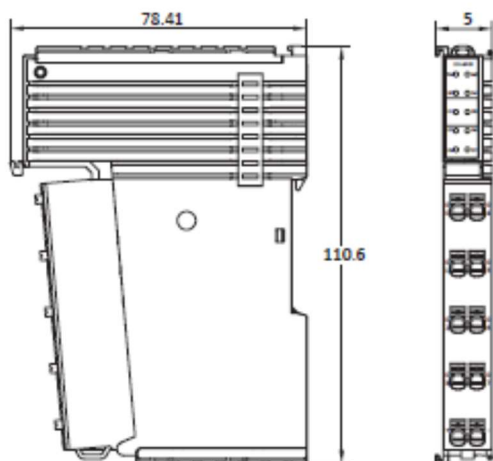

6.4.1.6. 4/8-channel digital relay output modules

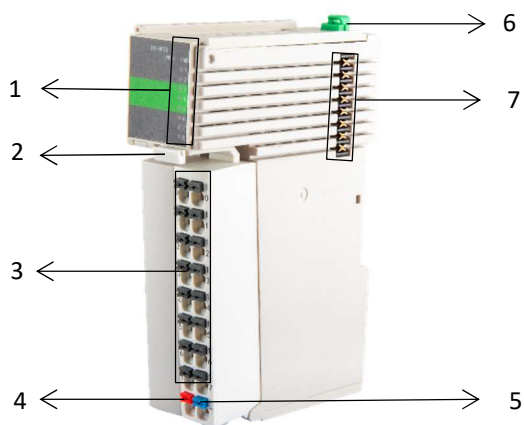

Item	Name	Function	Status
1	Module running indicator		
	PW	Backplane power indicator	Green: normal; Red: I/O power supply abnormal; Off: no backplane power
	MD	Module error indicator	Green: normal Red: Module channel error Green blinking: Connected but not configured; Red and green blinking: Backplane communication abnormal;
	00-07	Output signal indicator	Green: output "1" Off: output "0"
2	Terminal disassembly device	Press the device to separate the terminal block from the module	-
3	IO output terminal 0-7	IO signal wiring	-
4	24 V power terminal	24 V+	-
5	24 V power terminal	0 V	-
6	Module fixing device	Used to fix the module to the standard mounting rail	Pulling up: assembling position; Pressing down: locking position
7	Backplane bus interface	Backplane communication	-

6.4.1.7. 4/8-channel digital relay output modules technical data

FX20-DO-RD00

ARTICLE PROPERTIES

<b>PRODUCT TYPE</b>	FX20 series modular I/O system digital output modules	<b>PRODUCT GROUP</b>	IP20 modular I/O system
<b>DESCRIPTION</b>	FX20-submodule 4-channel output SSR, 230 V AC, IP20, DIN rail installation	<b>PU</b>	1 pc
		<b>COUNTRY OF ORIGIN</b>	CN

TECHNICAL DATA

<b>NUMBER OF DIGITAL OUTPUTS</b>	4	<b>OUTPUT HOLD</b>	Supports, configured by PLC or web server
<b>OUTPUT TYPE</b>	AC solid state relay	<b>RELAY RESPONSE TIME</b>	3 ... 10 ms
<b>CONTACT WORKING VOLTAGE</b>	230 V AC	<b>ELECTRICAL LIFE</b>	20 million times
<b>OUTPUT CURRENT</b>	Max. 0.5 A per channel	<b>CURRENT CONSUMPTION (5 V)</b>	80 mA
<b>OUTPUT LOAD TYPES</b>	Resistive loads, lamps	<b>PROCESS DATA LENGTH</b>	1 byte
<b>SWITCHING FREQUENCY</b>	Max. 0.5 Hz	<b>FAULT DIAGNOSIS METHOD</b>	LED, communication message

CONNECTION DATA

<b>WIRE CONNECTION</b>	Plug-in terminal block	<b>STRIPPED LENGTHS</b>	8 ... 10 mm 0.315 ... 0.394 in
<b>CROSS SECTION</b>	0.08 mm <sup>2</sup> ... 2.5 mm <sup>2</sup> AWG 28 ... 14		

ENVIRONMENTAL REQUIREMENTS

<b>PROTECTION CLASS</b>	IP20	<b>ELECTRICAL FAST TRANSIENT (EFT)</b>	Level A, per IEC 61000-4-4
<b>MOUNTING TYPE</b>	DIN-35 mm rail	<b>ELECTRO-STATIC DISCHARGE (ESD)</b>	Level A, per IEC 61000-4-2
<b>AMBIENT TEMPERATURE</b>	-5 ... +60 °C	<b>SURGE TEST</b>	Level A, per IEC 61000-4-5
<b>STORAGE TEMPERATURE</b>	-25 ... +70 °C	<b>VIBRATION RESISTANCE</b>	4 g, per IEC 60068-2-6
<b>RELATIVE HUMIDITY</b>	95%, non-condensing	<b>SHOCK RESISTANCE</b>	15 g, per IEC 60068-2-27
<b>OPERATING ALTITUDE</b>	0 ... 2000 m / 0 ... 6562 ft	<b>EU ROHS COMPLIANCE STATUS</b>	Yes
<b>POLLUTION DEGREE</b>	2, per IEC 61131-2	<b>MATERIAL COMPLIANCE</b>	Compliant with REACH

GENERAL DATA

<b>HOUSING MATERIAL</b>	PPE	<b>DIMENSIONS (H X W X D)</b>	110.6 x 28.1 x 78.4 mm
<b>WEIGHT</b>	90 g	<b>MTTF (25 °C)</b>	155 years
<b>COLOR</b>	Light gray	<b>APPROVALS</b>	CE

FX20-DO-RF50

ARTICLE PROPERTIES

<b>PRODUCT TYPE</b>	FX20 series modular I/O system digital output modules	<b>PRODUCT GROUP</b>	IP20 modular I/O system
<b>DESCRIPTION</b>	FX20-submoduel 8-channel output mechanical relays, output voltage 250 V AC / 30 V DC, IP20, DIN rail installation	<b>PU</b>	1 pc
		<b>COUNTRY OF ORIGIN</b>	CN

TECHNICAL DATA

<b>NUMBER OF DIGITAL OUTPUTS</b>	8	<b>OUTPUT HOLD</b>	Supports, configured by PLC or web server
<b>OUTPUT TYPE</b>	Mechanical relays	<b>RELAY RESPONSE TIME</b>	About 15 ms
<b>CONTACT WORKING VOLTAGE</b>	250 V AC / 30 V DC	<b>ELECTRICAL LIFE</b>	100,000 times
<b>OUTPUT CURRENT</b>	Max. 2 A per channel	<b>CURRENT CONSUMPTION (5 V)</b>	65 mA
<b>OUTPUT LOAD TYPES</b>	Resistive loads, lamps	<b>PROCESS DATA LENGTH</b>	1 byte
<b>SWITCHING FREQUENCY</b>	Less than 6 times per minute	<b>FAULT DIAGNOSIS METHOD</b>	LED, communication message

CONNECTION DATA

<b>WIRE CONNECTION</b>	Plug-in terminal block	<b>STRIPPED LENGTHS</b>	8 ... 10 mm 0.315 ... 0.394 in
<b>CROSS SECTION</b>	0.08 mm <sup>2</sup> ... 2.5 mm <sup>2</sup> AWG 28 ... 14		

ENVIRONMENTAL REQUIREMENTS

<b>PROTECTION CLASS</b>	IP20	<b>ELECTRICAL FAST TRANSIENT (EFT)</b>	Level A, per IEC 61000-4-4
<b>MOUNTING TYPE</b>	DIN-35 mm rail	<b>ELECTRO-STATIC DISCHARGE (ESD)</b>	Level A, per IEC 61000-4-2
<b>AMBIENT TEMPERATURE</b>	-5 ... +60 °C	<b>SURGE TEST</b>	Level A, per IEC 61000-4-5
<b>STORAGE TEMPERATURE</b>	-25 ... +70 °C	<b>VIBRATION RESISTANCE</b>	4 g, per IEC 60068-2-6
<b>RELATIVE HUMIDITY</b>	95%, non-condensing	<b>SHOCK RESISTANCE</b>	15 g, per IEC 60068-2-27
<b>OPERATING ALTITUDE</b>	0 ... 2000 m / 0 ... 6562 ft	<b>EU ROHS COMPLIANCE STATUS</b>	Yes
<b>POLLUTION DEGREE</b>	2, per IEC 61131-2	<b>MATERIAL COMPLIANCE</b>	Compliant with REACH

GENERAL DATA

<b>HOUSING MATERIAL</b>	PPE	<b>DIMENSIONS (H X W X D)</b>	110.6 x 28.1 x 78.4 mm
<b>WEIGHT</b>	90 g	<b>MTTF (25 °C)</b>	155 years

COLOR

Light gray

APPROVALS

CE

6.4.1.8. 4/8-channel digital relay output module profile drawing

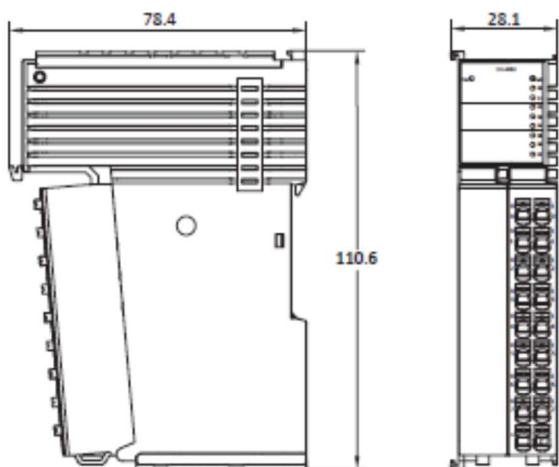

6.4.2. 16-channel digital input output module

6.4.2.1. 16-channel digital input module

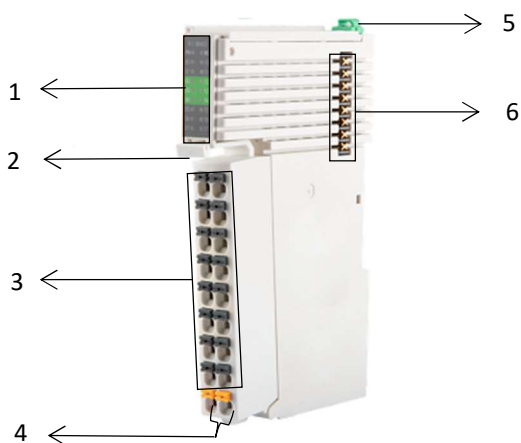

Item	Name	Function	Status
1	Module running indicator		
	PW	Backplane power indicator	Green: normal; Off: no backplane power
	MD	Module error indicator	Green: normal Red: Module channel error Green blinking: Connected but not configured; Red and green blinking: Backplane communication abnormal;
	00-07 10-17	Input signal indicators	Green: output 1 Off: output 0

2	Terminal disassembly device	Press the device to separate the terminal block from the module	-
3	IO input terminal 00-07/10-17	IO signal wiring	-
4	Common terminals	IO signal common terminals	0 V when the input signal is PNP, 24 V+ when the input signal is NPN
5	Module fixing device	Used to fix the module to the standard mounting rail	Pulling up: assembling position; Pressing down: locking position
6	Backplane interface	Backplane communication	-

### 6.4.2.2. 16 digital input module technical data

#### FX20-DI-BL60

##### ARTICLE PROPERTIES

<b>PRODUCT TYPE</b>	FX20 series modular I/O system digital input modules	<b>PRODUCT GROUP</b>	IP20 modular I/O system
<b>DESCRIPTION</b>	FX20-submodule 32-channel input PNP/ NPN, 24 V DC, IP20, DIN rail installation	<b>PU</b>	1 pc
		<b>COUNTRY OF ORIGIN</b>	CN

##### TECHNICAL DATA

<b>NUMBER OF DIGITAL INPUTS</b>	32	<b>INPUT FILTERING DELAY</b>	0 ms, 1 ms, 3 ms and 10 ms can be configured
<b>INPUT TYPE</b>	PNP / NPN	<b>CURRENT CONSUMPTION (5 V)</b>	60 mA
<b>INPUT SIGNAL '0'</b>	0 ... 5 V DC	<b>PROCESS DATA LENGTH</b>	4 bytes
<b>INPUT SIGNAL '1'</b>	18 ... 30 V DC	<b>FAULT DIAGNOSIS METHOD</b>	LED, communication message
<b>INPUT CURRENT PER CHANNEL FOR SIGNAL '1'</b>	Typ. 4 mA		

##### CONNECTION DATA

<b>WIRE CONNECTION</b>	Plug-in terminal block	<b>STRIPPED LENGTHS</b>	8 ... 10 mm 0.315 ... 0.394 in
<b>CROSS SECTION</b>	0.08 mm <sup>2</sup> ... 2.5 mm <sup>2</sup> AWG 28 ... 14		

##### ENVIRONMENTAL REQUIREMENTS

<b>PROTECTION CLASS</b>	IP20	<b>ELECTRICAL FAST TRANSIENT (EFT)</b>	Level A, per IEC 61000-4-4
<b>MOUNTING TYPE</b>	DIN-35 mm rail	<b>ELECTRO-STATIC DISCHARGE (ESD)</b>	Level A, per IEC 61000-4-2
<b>AMBIENT TEMPERATURE</b>	-5 ... +60 °C	<b>SURGE TEST</b>	Level A, per IEC 61000-4-5

<b>STORAGE TEMPERATURE</b>	-25 ... +70 °C	<b>VIBRATION RESISTANCE</b>	4 g, per IEC 60068-2-6
<b>RELATIVE HUMIDITY</b>	95%, non-condensing	<b>SHOCK RESISTANCE</b>	15 g, per IEC 60068-2-27
<b>OPERATING ALTITUDE</b>	0 ... 2000 m / 0 ... 6562 ft	<b>EU ROHS COMPLIANCE STATUS</b>	Yes
<b>POLLUTION DEGREE</b>	2, per IEC 61131-2	<b>MATERIAL COMPLIANCE</b>	Compliant with REACH

GENERAL DATA

<b>HOUSING MATERIAL</b>	PPE	<b>DIMENSIONS (H X W X D)</b>	110.6 x 28.1 x 78.4 mm
<b>WEIGHT</b>	128 g	<b>MTTF (25 °C)</b>	155 years
<b>COLOR</b>	Light gray	<b>APPROVALS</b>	CE

6.4.2.3. 16-channel digital output module

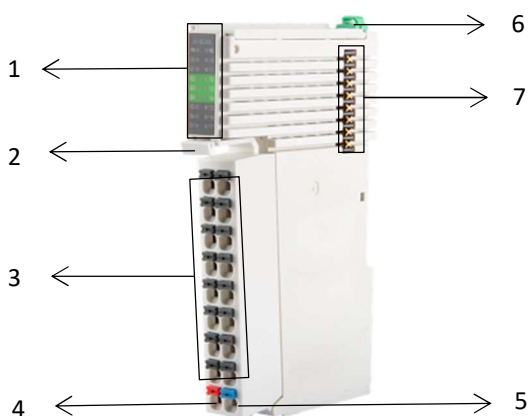

Item	Name	Function	Status
1	Module running indicator		
	PW	Backplane power indicator	Green: normal; Red: I/O power supply abnormal; Off: no backplane power
	MD	Module error indicator	Green: normal Red: Module channel error Green blinking: Connected but not configured; Red and green blinking: Backplane communication abnormal;
2	00-07 10-17	Output signal indicator	Green: output "1" Off: output "0"
	Terminal disassembly device	Press the device to separate the terminal block from the module	-
3	I/O output terminal 0-7,10-17	I/O signal wiring	-
4	24 V power terminal	24 V+	-

5	24 V power terminal	0 V	-
6	Module fixing device	Used to fix the module to the standard mounting rail	Pulling up: assembling position; Pressing down: locking position
7	Backplane expansion interface	Backplane communication	-

#### 6.4.2.4. 16-channel digital output module technical data

##### FX20-DO-BH00

###### ARTICLE PROPERTIES

<b>PRODUCT TYPE</b>	FX20 series modular I/O system digital output modules	<b>PRODUCT GROUP</b>	IP20 modular I/O system
<b>DESCRIPTION</b>	FX20-submoduel 16-channel output PNP, 24 V DC, 0.5 A, IP20, DIN rail installation	<b>PU</b>	1 pc
		<b>COUNTRY OF ORIGIN</b>	CN

###### TECHNICAL DATA

<b>NUMBER OF DIGITAL OUTPUTS</b>	16	<b>SWITCHING FREQUENCY</b>	Max. 1 kHz (Resistive loads) Max. 1 Hz (Inductive loads) Max. 10 Hz (Lamps)
<b>OUTPUT TYPE</b>	PNP	<b>OUTPUT HOLD</b>	Supports, configured by PLC or web server
<b>OUTPUT VOLTAGE</b>	24 V DC	<b>CURRENT CONSUMPTION (5 V)</b>	60 mA
<b>OUTPUT CURRENT</b>	Max. 0.5 A per channel, total 4 A per module	<b>PROCESS DATA LENGTH</b>	2 bytes
<b>OUTPUT LOAD TYPES</b>	Resistive loads, inductive loads, lamps	<b>FAULT DIAGNOSIS METHOD</b>	LED, communication message

###### CONNECTION DATA

<b>WIRE CONNECTION</b>	Plug-in terminal block	<b>STRIPPED LENGTHS</b>	8 ... 10 mm 0.315 ... 0.394 in
<b>CROSS SECTION</b>	0.08 mm <sup>2</sup> ... 2.5 mm <sup>2</sup> AWG 28 ... 14		

###### ENVIRONMENTAL REQUIREMENTS

<b>PROTECTION CLASS</b>	IP20	<b>ELECTRICAL FAST TRANSIENT (EFT)</b>	Level A, per IEC 61000-4-4
<b>MOUNTING TYPE</b>	DIN-35 mm rail	<b>ELECTRO-STATIC DISCHARGE (ESD)</b>	Level A, per IEC 61000-4-2
<b>AMBIENT TEMPERATURE</b>	-5 ... +60 °C	<b>SURGE TEST</b>	Level A, per IEC 61000-4-5
<b>STORAGE TEMPERATURE</b>	-25 ... +70 °C	<b>VIBRATION RESISTANCE</b>	4 g, per IEC 60068-2-6
<b>RELATIVE HUMIDITY</b>	95%, non-condensing	<b>SHOCK RESISTANCE</b>	15 g, per IEC 60068-2-27

<b>OPERATING ALTITUDE</b>	0 ... 2000 m / 0 ... 6562 ft	<b>EU ROHS COMPLIANCE STATUS</b>	Yes
<b>POLLUTION DEGREE</b>	2, per IEC 61131-2	<b>MATERIAL COMPLIANCE</b>	Compliant with REACH

## GENERAL DATA

<b>HOUSING MATERIAL</b>	PPE	<b>DIMENSIONS (H X W X D)</b>	110.6 x 15 x 78.4 mm
<b>WEIGHT</b>	63 g	<b>MTTF (25 °C)</b>	155 years
<b>COLOR</b>	Light gray	<b>APPROVALS</b>	CE

## FX20-DO-BH50

### ARTICLE PROPERTIES

<b>PRODUCT TYPE</b>	FX20 series modular I/O system digital output modules	<b>PRODUCT GROUP</b>	IP20 modular I/O system
<b>DESCRIPTION</b>	FX20-submodule 16-channel output NPN, 24 V DC, 0.5 A, IP20, DIN rail installation	<b>PU</b>	1 pc
		<b>COUNTRY OF ORIGIN</b>	CN

### TECHNICAL DATA

<b>NUMBER OF DIGITAL OUTPUTS</b>	16	<b>SWITCHING FREQUENCY</b>	Max. 1 kHz (Resistive loads) Max. 1 Hz (Inductive loads) Max. 10 Hz (Lamps)
<b>OUTPUT TYPE</b>	NPN	<b>OUTPUT HOLD</b>	Supports, configed by PLC or web server
<b>OUTPUT VOLTAGE</b>	24 V DC	<b>CURRENT CONSUMPTION (5 V)</b>	60 mA
<b>OUTPUT CURRENT</b>	Max. 0.5 A per channel, total 4 A per module	<b>PROCESS DATA LENGTH</b>	2 bytes
<b>OUTPUT LOAD TYPES</b>	Resistive loads, inductive loads, lamps	<b>FAULT DIAGNOSIS METHOD</b>	LED, communication message

### CONNECTION DATA

<b>WIRE CONNECTION</b>	Plug-in terminal block	<b>STRIPPED LENGTHS</b>	8 ... 10 mm 0.315 ... 0.394 in
<b>CROSS SECTION</b>	0.08 mm <sup>2</sup> ... 2.5 mm <sup>2</sup> AWG 28 ... 14		

### ENVIRONMENTAL REQUIREMENTS

<b>PROTECTION CLASS</b>	IP20	<b>ELECTRICAL FAST TRANSIENT (EFT)</b>	Level A, per IEC 61000-4-4
<b>MOUNTING TYPE</b>	DIN-35 mm rail	<b>ELECTRO-STATIC DISCHARGE (ESD)</b>	Level A, per IEC 61000-4-2
<b>AMBIENT TEMPERATURE</b>	-5 ... +60 °C	<b>SURGE TEST</b>	Level A, per IEC 61000-4-5
<b>STORAGE TEMPERATURE</b>	-25 ... +70 °C	<b>VIBRATION RESISTANCE</b>	4 g, per IEC 60068-2-6
<b>RELATIVE HUMIDITY</b>	95%, non-condensing	<b>SHOCK RESISTANCE</b>	15 g, per IEC 60068-2-27

<b>OPERATING ALTITUDE</b>	0 ... 2000 m / 0 ... 6562 ft	<b>EU ROHS COMPLIANCE STA-TUS</b>	Yes
<b>POLLUTION DEGREE</b>	2, per IEC 61131-2	<b>MATERIAL COMPLIANCE</b>	Compliant with REACH

GENERAL DATA

<b>HOUSING MATERIAL</b>	PPE	<b>DIMENSIONS (H X W X D)</b>	110.6 x 15 x 78.4 mm
<b>WEIGHT</b>	63 g	<b>MTTF (25 °C)</b>	155 years
<b>COLOR</b>	Light gray	<b>APPROVALS</b>	CE

6.4.2.5. 16 digital input output module profile drawing

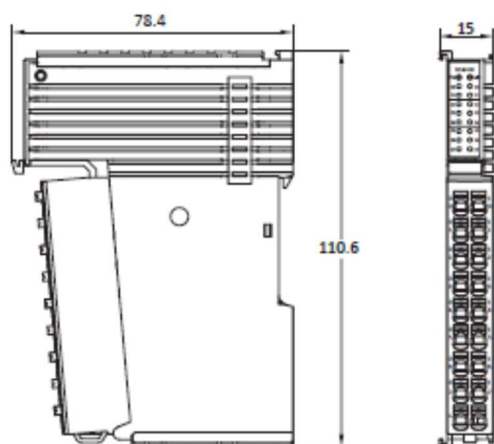

6.4.3. 32-channel digital input output module

6.4.3.1. 32-channel digital input module

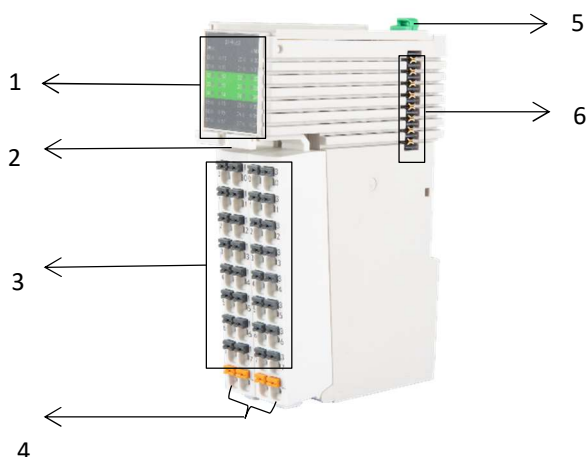

Item	Name	Function	Status
1	Module running indicator		
	PW	Backplane power indicator	Green: normal; Off: no backplane power
	MD	Module error indicator	Green: normal

			Red: Module channel error Green blinking: Connected but not configured; Red and green blinking: Backplane communication abnormal;
	00-07,10-17 20-27,30-37	Input signal indicator	Green: output "1" Off: output "0"
2	Terminal disassembly device	Press the device to separate the terminal block from the module	-
3	IO input terminal 00-07,10-17, 20-27,30-37	I/O signal wiring	-
4	Common terminals	I/O signal common terminals	0 V when the input signal is PNP, 24 V+ when the input signal is NPN
5	Module fixing device	Used to fix the module to the standard mounting rail	Pulling up: assembling position; Pressing down: locking position
6	Backplane expansion interface	Backplane communication	-

### 6.4.3.2. 32-channel digital input module technical data

#### FX20-DI-BL60

#### ARTICLE PROPERTIES

<b>PRODUCT TYPE</b>	FX20 series modular I/O system digital input modules	<b>PRODUCT GROUP</b>	IP20 modular I/O system
<b>DESCRIPTION</b>	FX20-submodule 32-channel input PNP/ NPN, 24 V DC, IP20, DIN rail installation	<b>PU</b>	1 pc
		<b>COUNTRY OF ORIGIN</b>	CN

#### TECHNICAL DATA

<b>NUMBER OF DIGITAL INPUTS</b>	32	<b>INPUT FILTERING DELAY</b>	0 ms, 1 ms, 3 ms and 10 ms can be configured
<b>INPUT TYPE</b>	PNP / NPN	<b>CURRENT CONSUMPTION (5 V)</b>	60 mA
<b>INPUT SIGNAL '0'</b>	0 ... 5 V DC	<b>PROCESS DATA LENGTH</b>	4 bytes
<b>INPUT SIGNAL '1'</b>	18 ... 30 V DC	<b>FAULT DIAGNOSIS METHOD</b>	LED, communication message
<b>INPUT CURRENT PER CHANNEL FOR SIGNAL '1'</b>	Typ. 4 mA		

#### CONNECTION DATA

<b>WIRE CONNECTION</b>	Plug-in terminal block	<b>STRIPPED LENGTHS</b>	8 ... 10 mm 0.315 ... 0.394 in
<b>CROSS SECTION</b>	0.08 mm <sup>2</sup> ... 2.5 mm <sup>2</sup> AWG 28 ... 14		

ENVIRONMENTAL REQUIREMENTS

<b>PROTECTION CLASS</b>	IP20	<b>ELECTRICAL FAST TRANSIENT (EFT)</b>	Level A, per IEC 61000-4-4
<b>MOUNTING TYPE</b>	DIN-35 mm rail	<b>ELECTRO-STATIC DISCHARGE (ESD)</b>	Level A, per IEC 61000-4-2
<b>AMBIENT TEMPERATURE</b>	-5 ... +60 °C	<b>SURGE TEST</b>	Level A, per IEC 61000-4-5
<b>STORAGE TEMPERATURE</b>	-25 ... +70 °C	<b>VIBRATION RESISTANCE</b>	4 g, per IEC 60068-2-6
<b>RELATIVE HUMIDITY</b>	95%, non-condensing	<b>SHOCK RESISTANCE</b>	15 g, per IEC 60068-2-27
<b>OPERATING ALTITUDE</b>	0 ... 2000 m / 0 ... 6562 ft	<b>EU ROHS COMPLIANCE STATUS</b>	Yes
<b>POLLUTION DEGREE</b>	2, per IEC 61131-2	<b>MATERIAL COMPLIANCE</b>	Compliant with REACH

GENERAL DATA

<b>HOUSING MATERIAL</b>	PPE	<b>DIMENSIONS (H X W X D)</b>	110.6 x 28.1 x 78.4 mm
<b>WEIGHT</b>	128 g	<b>MTTF (25 °C)</b>	155 years
<b>COLOR</b>	Light gray	<b>APPROVALS</b>	CE

6.4.3.3. 32-channel digital output module

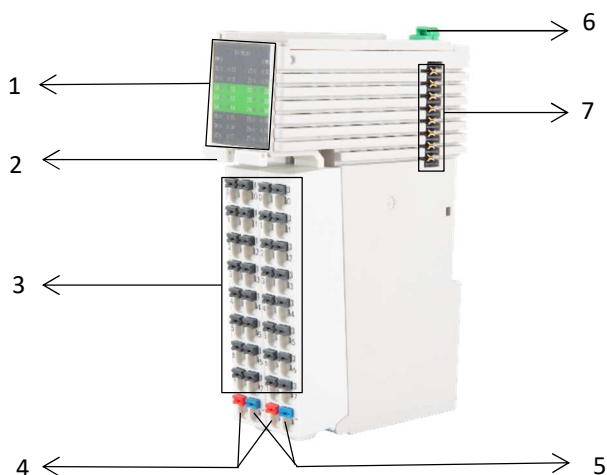

Item	Name	Function	Status
1	Module running indicators		
	PW	Backplane power indicator	Green: normal; Red: I/O power supply abnormal; Off: no backplane power
	MD	Module error indicator	Green: normal Red: Module channel error Green blinking: Connected but not configured; Red and green blinking: Backplane communication abnormal;
	00-07,10-17	Output signal indicator	Green: output "1"

	20-27,30-37		Off: output "0"
2	Terminal disassembly device	Press the device to separate the terminal block from the module	-
3	I/O output terminal 00-07,10-17, 20-27,30-37	I/O signal wiring	-
4	24 V power terminal	24V+	-
5	24 V power terminal	0V	-
6	Module fixing device	Used to fix the module to the standard mounting rail	Pulling up: assembling position; Pressing down: locking position
7	Backplane bus interface	Backplane communication	-

#### 6.4.3.4. 32-channel digital output module technical data

##### FX20-DO-BL00

###### ARTICLE PROPERTIES

<b>PRODUCT TYPE</b>	FX20 series modular I/O system digital output modules	<b>PRODUCT GROUP</b>	IP20 modular I/O system
<b>DESCRIPTION</b>	FX20-submodule 32-channel output PNP, 24 V DC, 0.5 A, IP20, DIN rail installation	<b>PU</b>	1 pc
		<b>COUNTRY OF ORIGIN</b>	CN

###### TECHNICAL DATA

<b>NUMBER OF DIGITAL OUTPUTS</b>	32	<b>SWITCHING FREQUENCY</b>	Max. 1 kHz (Resistive loads) Max. 1 Hz (Inductive loads) Max. 10 Hz (Lamps)
<b>OUTPUT TYPE</b>	PNP	<b>OUTPUT HOLD</b>	Supports, configed by PLC or web server
<b>OUTPUT VOLTAGE</b>	24 V DC	<b>CURRENT CONSUMPTION (5 V)</b>	60 mA
<b>OUTPUT CURRENT</b>	Max. 0.5 A per channel, total 4 A per module	<b>PROCESS DATA LENGTH</b>	4 bytes
<b>OUTPUT LOAD TYPES</b>	Resistive loads, inductive loads, lamps	<b>FAULT DIAGNOSIS METHOD</b>	LED, communication message

###### CONNECTION DATA

<b>WIRE CONNECTION</b>	Plug-in terminal block	<b>STRIPPED LENGTHS</b>	8 ... 10 mm 0.315 ... 0.394 in
<b>CROSS SECTION</b>	0.08 mm <sup>2</sup> ... 2.5 mm <sup>2</sup> AWG 28 ... 14		

###### ENVIRONMENTAL REQUIREMENTS

<b>PROTECTION CLASS</b>	IP20	<b>ELECTRICAL FAST TRANSIENT (EFT)</b>	Level A, per IEC 61000-4-4
-------------------------	------	--	----------------------------

<b>MOUNTING TYPE</b>	DIN-35 mm rail	<b>ELECTRO-STATIC DISCHARGE (ESD)</b>	Level A, per IEC 61000-4-2
<b>AMBIENT TEMPERATURE</b>	-5 ... +60 °C	<b>SURGE TEST</b>	Level A, per IEC 61000-4-5
<b>STORAGE TEMPERATURE</b>	-25 ... +70 °C	<b>VIBRATION RESISTANCE</b>	4 g, per IEC 60068-2-6
<b>RELATIVE HUMIDITY</b>	95%, non-condensing	<b>SHOCK RESISTANCE</b>	15 g, per IEC 60068-2-27
<b>OPERATING ALTITUDE</b>	0 ... 2000 m / 0 ... 6562 ft	<b>EU ROHS COMPLIANCE STATUS</b>	Yes
<b>POLLUTION DEGREE</b>	2, per IEC 61131-2	<b>MATERIAL COMPLIANCE</b>	Compliant with REACH

## GENERAL DATA

<b>HOUSING MATERIAL</b>	PPE	<b>DIMENSIONS (H X W X D)</b>	110.6 x 28.1 x 78.4 mm
<b>WEIGHT</b>	128 g	<b>MTTF (25 °C)</b>	155 years
<b>COLOR</b>	Light gray	<b>APPROVALS</b>	CE

## FX20-DO-BL50

## ARTICLE PROPERTIES

<b>PRODUCT TYPE</b>	FX20 series modular I/O system digital output modules	<b>PRODUCT GROUP</b>	IP20 modular I/O system
<b>DESCRIPTION</b>	FX20-submodule 32-channel output NPN, 24 V DC, 0.5 A, IP20, DIN rail installation	<b>PU</b>	1 pc
		<b>COUNTRY OF ORIGIN</b>	CN

## TECHNICAL DATA

<b>NUMBER OF DIGITAL OUTPUTS</b>	32	<b>SWITCHING FREQUENCY</b>	Max. 1 kHz (Resistive loads) Max. 1 Hz (Inductive loads) Max. 10 Hz (Lamps)
<b>OUTPUT TYPE</b>	NPN	<b>OUTPUT HOLD</b>	Supports, configed by PLC or web server
<b>OUTPUT VOLTAGE</b>	24 V DC	<b>CURRENT CONSUMPTION (5 V)</b>	60 mA
<b>OUTPUT CURRENT</b>	Max. 0.5 A per channel, total 4 A per module	<b>PROCESS DATA LENGTH</b>	4 bytes
<b>OUTPUT LOAD TYPES</b>	Resistive loads, inductive loads, lamps	<b>FAULT DIAGNOSIS METHOD</b>	LED, communication message

## CONNECTION DATA

<b>WIRE CONNECTION</b>	Plug-in terminal block	<b>STRIPPED LENGTHS</b>	8 ... 10 mm 0.315 ... 0.394 in
<b>CROSS SECTION</b>	0.08 mm <sup>2</sup> ... 2.5 mm <sup>2</sup> AWG 28 ... 14		

## ENVIRONMENTAL REQUIREMENTS

<b>PROTECTION CLASS</b>	IP20	<b>ELECTRICAL FAST TRANSIENT (EFT)</b>	Level A, per IEC 61000-4-4
-------------------------	------	--	----------------------------

<b>MOUNTING TYPE</b>	DIN-35 mm rail	<b>ELECTRO-STATIC DISCHARGE (ESD)</b>	Level A, per IEC 61000-4-2
<b>AMBIENT TEMPERATURE</b>	-5 ... +60 °C	<b>SURGE TEST</b>	Level A, per IEC 61000-4-5
<b>STORAGE TEMPERATURE</b>	-25 ... +70 °C	<b>VIBRATION RESISTANCE</b>	4 g, per IEC 60068-2-6
<b>RELATIVE HUMIDITY</b>	95%, non-condensing	<b>SHOCK RESISTANCE</b>	15 g, per IEC 60068-2-27
<b>OPERATING ALTITUDE</b>	0 ... 2000 m / 0 ... 6562 ft	<b>EU ROHS COMPLIANCE STATUS</b>	Yes
<b>POLLUTION DEGREE</b>	2, per IEC 61131-2	<b>MATERIAL COMPLIANCE</b>	Compliant with REACH

**GENERAL DATA**

<b>HOUSING MATERIAL</b>	PPE	<b>DIMENSIONS (H X W X D)</b>	110.6 x 28.1 x 78.4 mm
<b>WEIGHT</b>	128 g	<b>MTTF (25 °C)</b>	155 years
<b>COLOR</b>	Light gray	<b>APPROVALS</b>	CE

6.4.3.5. 32-channel digital input/output module profile drawing

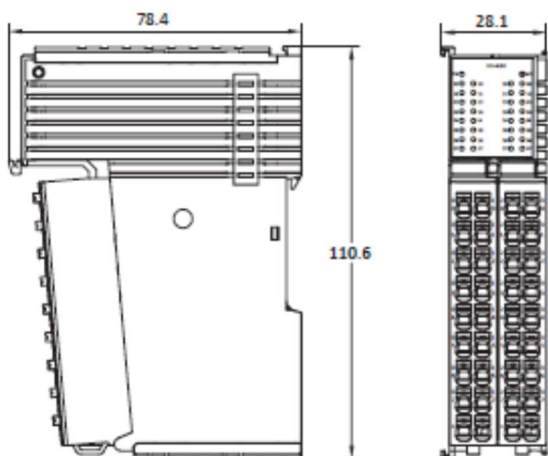

6.4.4. 4-channel analog input/output module

6.4.4.1. 4-channel analog input module

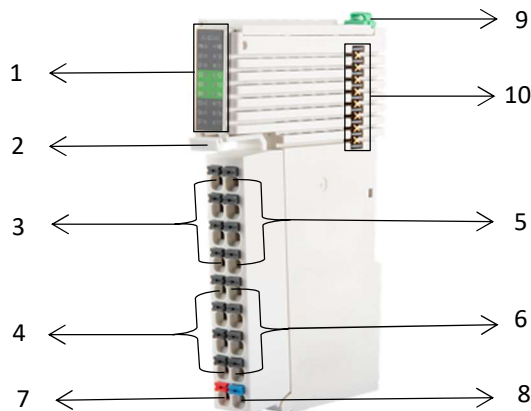

Item	Name	Function	Status
1	Module running indicators		
	PW	Backplane power indicator	Green: normal; Red: I/O power supply abnormal; Off: no backplane power
	MD	Module error indicator	Green: normal Red: Module channel error Green blinking: Connected but not configured; Red and green blinking: Backplane communication abnormal;
	C1-C4	Input signal indicator	Green: input normal Red: input over range
2	Terminal disassembly device	Press the device to separate the terminal block from the module	-
3	Analog input channel 0	Analog input	-
4	Analog input channel 1	Analog input	-
5	Analog input channel 2	Analog input	-
6	Analog input channel 3	Analog input	-
7	24 V power terminal	24V+	-
8	24 V power terminal	0V	-
9	Module fixing device	Used to fix the module to the standard mounting rail	Pulling up: assembling position; Pressing down: locking position
10	Backplane bus interface	Backplane communication	-

6.4.4.2. 4-channel analog input module technical data

FX20-AI-BD60

ARTICLE PROPERTIES

<b>PRODUCT TYPE</b>	FX20 series modular I/O system analog input modules	<b>PRODUCT GROUP</b>	IP20 modular I/O system
<b>DESCRIPTION</b>	FX20-submodule 4-channel analog input, voltage / current types, 24 V DC, IP20, DIN rail installation	<b>PU</b>	1 pc
		<b>COUNTRY OF ORIGIN</b>	CN

TECHNICAL DATA

<b>NUMBER OF ANALOG INPUTS</b>	4	<b>MEASURING ACCURACY</b>	± 0.2 %
<b>INPUT TYPE</b>	0 ... 10 V, ± 10 V, 1 ... 5 V, 0/4 ... 20 mA, ±20 mA	<b>OPERATING VOLTAGE</b>	24 V DC

<b>INPUT IMPEDANCE</b>	Current type: 250 Ω Voltage type: 1 MΩ	<b>CURRENT CONSUMPTION (5 V)</b>	60 mA
<b>INPUT RESOLUTION</b>	16 bits	<b>PROCESS DATA LENGTH</b>	8 bytes
<b>CONVERTING TIME</b>	3 ms	<b>FAULT DIAGNOSIS METHOD</b>	LED, communication message

CONNECTION DATA

<b>WIRE CONNECTION</b>	Plug-in terminal block	<b>STRIPPED LENGTHS</b>	8 ... 10 mm 0.315 ... 0.394 in
<b>CROSS SECTION</b>	0.08 ... 2.5 mm <sup>2</sup> AWG 28 ... 14		

ENVIRONMENTAL REQUIREMENTS

<b>PROTECTION CLASS</b>	IP20	<b>ELECTRICAL FAST TRANSIENT (EFT)</b>	Level A, per IEC 61000-4-4
<b>MOUNTING TYPE</b>	DIN-35 mm rail	<b>ELECTRO-STATIC DISCHARGE (ESD)</b>	Level A, per IEC 61000-4-2
<b>AMBIENT TEMPERATURE</b>	-5 ... +60 °C	<b>SURGE TEST</b>	Level A, per IEC 61000-4-5
<b>STORAGE TEMPERATURE</b>	-25 ... +70 °C	<b>VIBRATION RESISTANCE</b>	4 g, per IEC 60068-2-6
<b>RELATIVE HUMIDITY</b>	95%, non-condensing	<b>SHOCK RESISTANCE</b>	15 g, per IEC 60068-2-27
<b>OPERATING ALTITUDE</b>	0 ... 2000 m / 0 ... 6562 ft	<b>EU ROHS COMPLIANCE STATUS</b>	Yes
<b>POLLUTION DEGREE</b>	2, compliant with IEC 61131-2	<b>MATERIAL COMPLIANCE</b>	Compliant with REACH

GENERAL DATA

<b>HOUSING MATERIAL</b>	PPE	<b>DIMENSIONS (H X W X D)</b>	110.6 x 15 x 78.4 mm
<b>WEIGHT</b>	63 g	<b>MTTF (25 °C)</b>	196 years
<b>COLOR</b>	Light gray	<b>APPROVALS</b>	CE

6.4.4.3. 4-channel analog output module

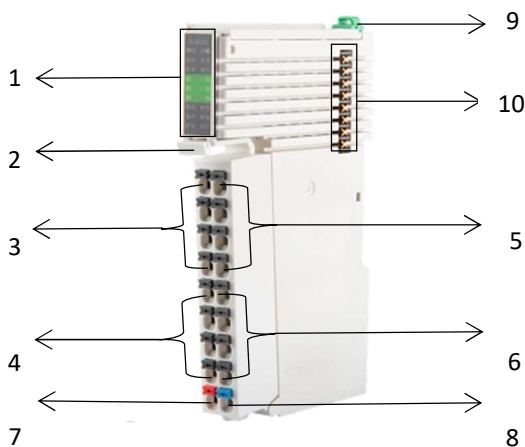

Item	Name	Function	Status
1	Module running indicators		
	PW	Backplane power indicator	Green: normal; Red: I/O power supply abnormal; Off: no backplane power
	MD	Module error indicator	Green: normal Red: Module channel error Green blinking: Connected but not be configured; Red and green blinking: Backplane communication abnormal.
	C1-C4	Output signal indicator	Green: output normal Red: output over range
2	Terminal disassembly device	Press the device to separate the terminal block from the module	-
3	Analog output 0	Analog output	-
4	Analog output 1	Analog output	-
5	Analog output 2	Analog output	-
6	Analog output 3	Analog output	-
7	24 V power terminal	24 V+	-
8	24 V power terminal	0 V	-
9	Module fixing device	Used to fix the module to the standard mounting rail	Pulling up: assembling position; Pressing down: locking position
10	Backplane bus interface	Backplane communication	

6.4.4.4. 4-channel analog output module technical data

FX20-AO-BD60

ARTICLE PROPERTIES

<b>PRODUCT TYPE</b>	FX20 series modular I/O system analog output modules	<b>PRODUCT GROUP</b>	IP20 modular I/O system
<b>DESCRIPTION</b>	FX20-submodule 4-channel analog output, voltage/current types, 24 V DC, IP20, DIN rail installation	<b>PU</b>	1 pc
		<b>COUNTRY OF ORIGIN</b>	CN

TECHNICAL DATA

<b>NUMBER OF ANALOG INPUTS</b>	4	<b>OPERATING VOLTAGE</b>	24 V DC
<b>OUTPUT TYPE</b>	0 ... 10 V, ± 10 V, 1 ... 5 V,	<b>CURRENT CONSUMPTION (5 V)</b>	60 mA

<b>OUTPUT RESOLUTION</b>	0/4 ... 20 mA	<b>PROCESS DATA LENGTH</b>	8 bytes
<b>CONVERTING TIME</b>	16 bits	<b>FAULT DIAGNOSIS METHOD</b>	LED, communication message
<b>MEASURING ACCURACY</b>	2 ms ± 0.2 %		

CONNECTION DATA

<b>WIRE CONNECTION</b>	Plug-in terminal block	<b>STRIPPED LENGTHS</b>	8 ... 10 mm 0.315 ... 0.394 in
<b>CROSS SECTION</b>	0.08 mm <sup>2</sup> ... 2.5 mm <sup>2</sup> AWG 28 ... 14		

ENVIRONMENTAL REQUIREMENTS

<b>PROTECTION CLASS</b>	IP20	<b>ELECTRICAL FAST TRANSIENT (EFT)</b>	Level A, per IEC 61000-4-4
<b>MOUNTING TYPE</b>	DIN-35 mm rail	<b>ELECTRO-STATIC DISCHARGE (ESD)</b>	Level A, per IEC 61000-4-2
<b>AMBIENT TEMPERATURE</b>	-5 ... +60 °C	<b>SURGE TEST</b>	Level A, per IEC 61000-4-5
<b>STORAGE TEMPERATURE</b>	-25 ... +70 °C	<b>VIBRATION RESISTANCE</b>	4 g, per IEC 60068-2-6
<b>RELATIVE HUMIDITY</b>	95%, non-condensing	<b>SHOCK RESISTANCE</b>	15 g, per IEC 60068-2-27
<b>OPERATING ALTITUDE</b>	0 ... 2000 m / 0 ... 6562 ft	<b>EU ROHS COMPLIANCE STATUS</b>	Yes
<b>POLLUTION DEGREE</b>	2, per IEC 61131-2	<b>MATERIAL COMPLIANCE</b>	Compliant with REACH

GENERAL DATA

<b>HOUSING MATERIAL</b>	PPE	<b>DIMENSIONS (H X W X D)</b>	110.6 x 15 x 78.4 mm
<b>WEIGHT</b>	63 g	<b>MTTF (25 °C)</b>	196 years
<b>COLOR</b>	Light gray	<b>APPROVALS</b>	CE

6.4.4.5. 4-channel analog input output module profile drawing

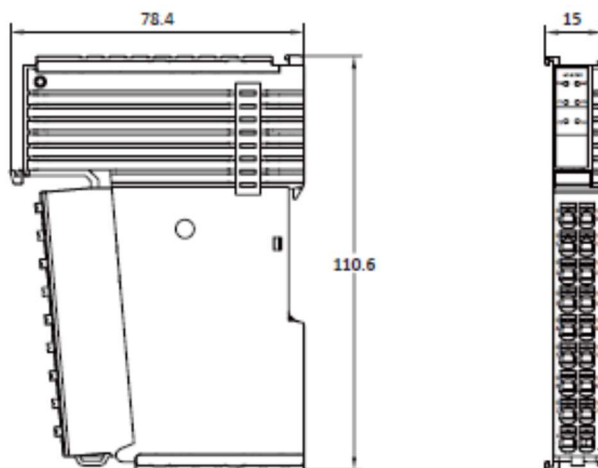

6.4.5. 8-channel analog input output modules

6.4.5.1. 8-channel analog input modules

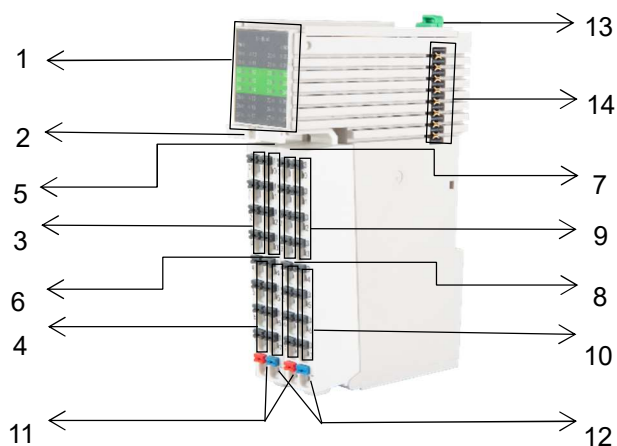

Item	Name	Function	Status
1	Module running indicators		
	PW	Backplane power indicator	Green: normal; Red: I/O power supply abnormal; Off: no backplane power
	MD	Module error indicator	Green: normal Red: Module channel error Green blinking: Connected but not configured; Red and green blinking: Backplane communication abnormal;
	C1-C8	Input signal indicator	Green: input normal Red: input over range
2	Terminal disassembly device	Press the device to separate the terminal block from the module	-
3	Analog input channel 0	Analog input	-
4	Analog input channel 1	Analog input	-
5	Analog input channel 2	Analog input	-
6	Analog input channel 3	Analog input	-
7	Analog input channel 4	Analog input	-
8	Analog input channel 5	Analog input	-
9	Analog input channel 6	Analog input	-
10	Analog input channel 7	Analog input	-
11	24 V power terminal	24 V+	-
12	24 V power terminal	0 V	-
13	Module fixing device	Used to fix the module to the	Pulling up: assembling position;

		standard mounting rail	Pressing down: locking position
14	Backplane bus interface	Backplane communication	-

### 6.4.5.2. 8-channel analog input module technical data

#### FX20-AI-BF60

##### ARTICLE PROPERTIES

<b>PRODUCT TYPE</b>	FX20 series modular I/O system analog input modules	<b>PRODUCT GROUP</b>	IP20 modular I/O system
<b>DESCRIPTION</b>	FX20-submodule 8-channel analog input, voltage / current types, 24 V DC, IP20, DIN rail installation	<b>PU</b>	1 pc
		<b>COUNTRY OF ORIGIN</b>	CN

##### TECHNICAL DATA

<b>NUMBER OF ANALOG INPUTS</b>	8	<b>MEASURING ACCURACY</b>	± 0.2 %
<b>INPUT TYPE</b>	0 ... 10 V, ± 10 V, 1 ... 5 V, 0/4 ... 20 mA, ± 20 mA	<b>OPERATING VOLTAGE</b>	24 V DC
<b>INPUT IMPEDANCE</b>	Current type: 250 Ω Voltage type: 1 MΩ	<b>CURRENT CONSUMPTION (5 V)</b>	60 mA
<b>INPUT RESOLUTION</b>	16 bits	<b>PROCESS DATA LENGTH</b>	16 bytes
<b>CONVERTING TIME</b>	3 ms	<b>FAULT DIAGNOSIS METHOD</b>	LED, communication message

##### CONNECTION DATA

<b>WIRE CONNECTION</b>	Plug-in terminal block	<b>STRIPPED LENGTHS</b>	8 ... 10 mm 0.315 ... 0.394 in
<b>CROSS SECTION</b>	0.08 mm <sup>2</sup> ... 2.5 mm <sup>2</sup> AWG 28 ... 14		

##### ENVIRONMENTAL REQUIREMENTS

<b>PROTECTION CLASS</b>	IP20	<b>ELECTRICAL FAST TRANSIENT (EFT)</b>	Level A, per IEC 61000-4-4
<b>MOUNTING TYPE</b>	DIN-35 mm rail	<b>ELECTRO-STATIC DISCHARGE (ESD)</b>	Level A, per IEC 61000-4-2
<b>AMBIENT TEMPERATURE</b>	-5 ... +60 °C	<b>SURGE TEST</b>	Level A, per IEC 61000-4-5
<b>STORAGE TEMPERATURE</b>	-25 ... +70 °C	<b>VIBRATION RESISTANCE</b>	4 g, per IEC 60068-2-6
<b>RELATIVE HUMIDITY</b>	95%, non-condensing	<b>SHOCK RESISTANCE</b>	15 g, per IEC 60068-2-27
<b>OPERATING ALTITUDE</b>	0 ... 2000 m / 0 ... 6562 ft	<b>EU ROHS COMPLIANCE STATUS</b>	Yes
<b>POLLUTION DEGREE</b>	2, per IEC 61131-2	<b>MATERIAL COMPLIANCE</b>	Compliant with REACH

##### GENERAL DATA

<b>HOUSING MATERIAL</b>	PPE	<b>DIMENSIONS (H X W X D)</b>	110.6 x 28.1 x 78.4 mm
<b>WEIGHT</b>	128 g	<b>MTTF (25 °C)</b>	196 years

6.4.5.3. 8-channel analog output module

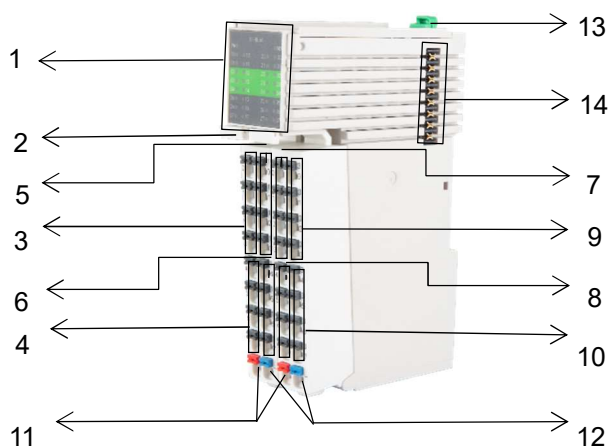

Item	Name	Function	Status
1	Module running indicator		
	PW	Backplane power indicator	Green: normal; Red: I/O power supply abnormal; Off: no backplane power
	MD	Module error indicator	Green: normal Red: Module channel error Green blinking: Connected but not configured; Red and green blinking: Backplane communication abnormal;
	C1-C8	Output signal indicator	Green: output normal Red: output over range
2	Terminal disassembly device	Press the device to separate the terminal block from the module	-
3	Analog output 0	Analog output	-
4	Analog output 1	Analog output	-
5	Analog output 2	Analog output	-
6	Analog output 3	Analog output	-
7	Analog output 4	Analog output	-
8	Analog output 5	Analog output	-
9	Analog output 6	Analog output	-
10	Analog output 7	Analog output	-
11	24 V power terminal	24 V+	-
12	24 V power terminal	0 V	-
13	Module fixing device	Used to fix the module to the	Pulling up: assembling position;

		standard mounting rail	Pressing down: locking position
14	Backplane bus interface	Backplane communication	-

#### 6.4.5.4. 8-channel analog output module technical data

##### FX20-AO-BF60

###### ARTICLE PROPERTIES

<b>PRODUCT TYPE</b>	FX20 series modular I/O system analog output modules	<b>PRODUCT GROUP</b>	IP20 modular I/O system
<b>DESCRIPTION</b>	FX20-submodule 8-channel analog output, voltage / current types, 24 V DC, IP20, DIN rail installation	<b>PU</b>	1 pc
		<b>COUNTRY OF ORIGIN</b>	CN

###### TECHNICAL DATA

<b>NUMBER OF ANALOG INPUTS</b>	8	<b>OPERATING VOLTAGE</b>	24 V DC
<b>OUTPUT TYPE</b>	0 ... 10 V, ± 10 V, 1 ... 5 V, 0/4 ... 20 mA	<b>CURRENT CONSUMPTION (5 V)</b>	60 mA
<b>OUTPUT RESOLUTION</b>	16 bits	<b>PROCESS DATA LENGTH</b>	16 bytes
<b>CONVERTING TIME</b>	2 ms	<b>FAULT DIAGNOSIS METHOD</b>	LED, communication message
<b>MEASURING ACCURACY</b>	± 0.2 %		

###### CONNECTION DATA

<b>WIRE CONNECTION</b>	Plug-in terminal block	<b>STRIPPED LENGTHS</b>	8 ... 10 mm, 0.315 ... 0.394 in
<b>CROSS SECTION</b>	0.08 mm <sup>2</sup> ... 2.5 mm <sup>2</sup> , AWG 28 ... 14		

###### ENVIRONMENTAL REQUIREMENTS

<b>PROTECTION CLASS</b>	IP20	<b>ELECTRO-STATIC DISCHARGE (ESD)</b>	Level A, per IEC 61000-4-2
<b>MOUNTING TYPE</b>	DIN-35 mm rail	<b>SURGE TEST</b>	Level A, per IEC 61000-4-5
<b>AMBIENT TEMPERATURE</b>	-5 ... +60 °C	<b>VIBRATION RESISTANCE</b>	4 g, per IEC 60068-2-6
<b>STORAGE TEMPERATURE</b>	-25 ... +70 °C	<b>SHOCK RESISTANCE</b>	15 g, per IEC 60068-2-27
<b>RELATIVE HUMIDITY</b>	95%, non-condensing	<b>EU ROHS COMPLIANCE STATUS</b>	Yes
<b>OPERATING ALTITUDE</b>	0 ... 2000 m / 0 ... 6562 ft	<b>MATERIAL COMPLIANCE</b>	Compliant with REACH
<b>POLLUTION DEGREE</b>	2, per IEC 61131-2	<b>DIMENSIONS (H X W X D)</b>	110.6 x 28 x 78.4 mm
<b>ELECTRICAL FAST TRANSIENT (EFT)</b>	Level A, per IEC 61000-4-4	<b>CONFORMITY MARKING</b>	CE

###### GENERAL DATA

<b>HOUSING MATERIAL</b>	PPE	<b>DIMENSIONS (H X W X D)</b>	110.6 x 28 x 78.4 mm
-------------------------	-----	-------------------------------	----------------------

WEIGHT	63 g	MTTF (25 °C)	196 years
COLOR	Light gray	APPROVALS	CE

6.4.5.5. 8-channel analog input/output module profile drawing

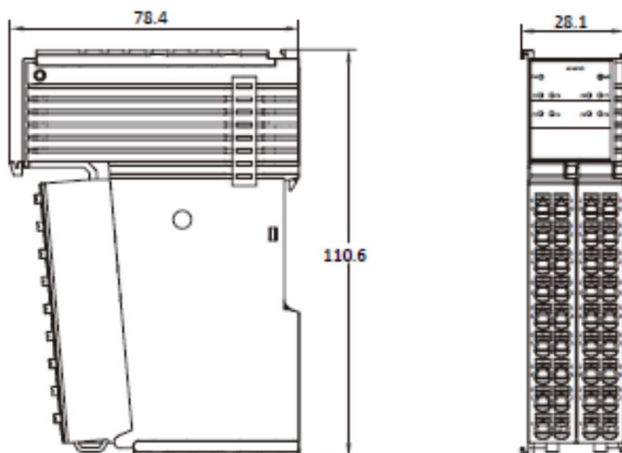

6.4.6. 4-channel temperature measurement modules

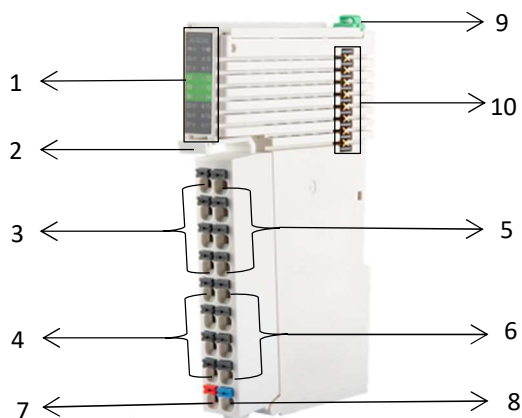

Item	Name	Function	Status
1	Module running indicators		
	PW	Backplane power indicator	Green: normal; Red: I/O power supply abnormal; Off: no backplane power
	MD	Module error indicator	Green: normal Red: Module channel error Green blinking: Connected but not configured; Red and green blinking: Backplane communication abnormal;
	C1-C4	Temperature measurement signal	Green: input normal

		indicator	Red: input over range
2	Terminal disassembly device	Press the device to separate the terminal block from the module	-
3	Temp measurement channel 0	Analog output	-
4	Temp measurement channel 1	Analog output	-
5	Temp measurement channel 2	Analog output	-
6	Temp measurement channel 3	Analog output	-
7	24 V power terminal	24V+	-
8	24 V power terminal	0V	-
9	Module fixing device	Used to fix the module to the standard mounting rail	Pulling up: assembling position; Pressing down: locking position
10	Backplane bus interface	Backplane communication	-

6.4.6.1. 4-channel temperature measurement modules technical data

FX20-AI-BD80

ARTICLE PROPERTIES

<b>PRODUCT TYPE</b>	FX20 series modular I/O system analog input modules	<b>PRODUCT GROUP</b>	IP20 modular I/O system
<b>DESCRIPTION</b>	FX20-submodule 4-channel RTD measurement, 24 V DC, IP20, DIN rail installation	<b>PU</b>	1 pc
		<b>COUNTRY OF ORIGIN</b>	CN

TECHNICAL DATA

<b>NUMBER OF ANALOG INPUTS</b>	4	<b>MEASUREMENT ACCURACY</b>	Within 2 °C
<b>INPUT TYPE</b>	Thermal resistance, (2-wire, 3-wire): PT100, PT1000	<b>OPERATING VOLTAGE</b>	24 V DC
<b>INPUT RESOLUTION</b>	16 bits	<b>CURRENT CONSUMPTION (5 V)</b>	60 mA
<b>CONVERTING TIME(TYP.)</b>	320 ms	<b>PROCESS DATA LENGTH</b>	8 bytes
<b>SENSITIVITY</b>	0.1 °C	<b>FAULT DIAGNOSIS METHOD</b>	LED, communication message

CONNECTION DATA

<b>WIRE CONNECTION</b>	Plug-in terminal block	<b>STRIPPED LENGTHS</b>	8 ... 10 mm, 0.315 ... 0.394 in
<b>CROSS SECTION</b>	0.08 mm <sup>2</sup> ... 2.5 mm <sup>2</sup> , AWG 28 ... 14		

ENVIRONMENTAL REQUIREMENTS

<b>PROTECTION CLASS</b>	IP20	<b>ELECTRICAL FAST TRANSIENT (EFT)</b>	Level A, per IEC 61000-4-4
<b>MOUNTING TYPE</b>	DIN-35 mm rail	<b>ELECTRO-STATIC DISCHARGE (ESD)</b>	Level A, per IEC 61000-4-2
<b>AMBIENT TEMPERATURE</b>	-5 ... +60 °C	<b>SURGE TEST</b>	Level A, per IEC 61000-4-5
<b>STORAGE TEMPERATURE</b>	-25 ... +70 °C	<b>VIBRATION RESISTANCE</b>	4 g, per IEC 60068-2-6
<b>RELATIVE HUMIDITY</b>	95%, non-condensing	<b>VIBRATION RESISTANCE</b>	4 g, per IEC 60068-2-6
<b>OPERATING ALTITUDE</b>	0 ... 2000 m / 0 ... 6562 ft	<b>SHOCK RESISTANCE</b>	15 g, per IEC 60068-2-27
<b>HOUSING MATERIAL</b>	PPE	<b>EU ROHS COMPLIANCE STATUS</b>	Yes
<b>POLLUTION DEGREE</b>	2, compliant with IEC 61131-2	<b>MATERIAL COMPLIANCE</b>	Compliant with REACH

#### GENERAL DATA

<b>HOUSING MATERIAL</b>	PPE	<b>DIMENSIONS (H X W X D)</b>	110.6 x 15 x 78.4 mm
<b>WEIGHT</b>	63 g	<b>MTTF (25 °C)</b>	196 years
<b>COLOR</b>	Light gray	<b>APPROVALS</b>	CE

#### FX20-AI-BD90

#### ARTICLE PROPERTIES

<b>PRODUCT TYPE</b>	FX20 series modular I/O system analog input modules	<b>PRODUCT GROUP</b>	IP20 modular I/O system
<b>DESCRIPTION</b>	FX20-submodule 4-channel TC measurement, 24 V DC, IP20, DIN rail installation	<b>PU</b>	1 pc
		<b>COUNTRY OF ORIGIN</b>	CN

#### TECHNICAL DATA

<b>NUMBER OF ANALOG INPUTS</b>	4	<b>MEASUREMENT ACCURACY</b>	Within 2 °C
<b>INPUT TYPE</b>	Thermocouples: J, K, T, N, E types	<b>OPERATING VOLTAGE</b>	24 V DC
<b>INPUT RESOLUTION</b>	16 bits	<b>CURRENT CONSUMPTION (5 V)</b>	60 mA
<b>CONVERTING TIME(TYP.)</b>	320 ms	<b>PROCESS DATA LENGTH</b>	8 bytes
<b>SENSITIVITY</b>	0.1 °C	<b>FAULT DIAGNOSIS METHOD</b>	LED, communication message

#### CONNECTION DATA

<b>WIRE CONNECTION</b>	Plug-in terminal block	<b>STRIPPED LENGTHS</b>	8 ... 10 mm, 0.315 ... 0.394 in
<b>CROSS SECTION</b>	0.08 mm <sup>2</sup> ... 2.5 mm <sup>2</sup> , AWG 28 ... 14		

#### ENVIRONMENTAL REQUIREMENTS

<b>PROTECTION CLASS</b>	IP20	<b>ELECTRICAL FAST TRANSIENT (EFT)</b>	Level A, per IEC 61000-4-4
-------------------------	------	--	----------------------------

<b>MOUNTING TYPE</b>	DIN-35 mm rail	<b>ELECTRO-STATIC DISCHARGE (ESD)</b>	Level A, per IEC 61000-4-2
<b>AMBIENT TEMPERATURE</b>	-5 ... +60 °C	<b>SURGE TEST</b>	Level A, per IEC 61000-4-5
<b>STORAGE TEMPERATURE</b>	-25 ... +70 °C	<b>VIBRATION RESISTANCE</b>	4 g, per IEC 60068-2-6
<b>RELATIVE HUMIDITY</b>	95%, non-condensing	<b>SHOCK RESISTANCE</b>	15 g, per IEC 60068-2-27
<b>OPERATING ALTITUDE</b>	0 ... 2000 m / 0 ... 6562 ft	<b>EU ROHS COMPLIANCE STATUS</b>	Yes
<b>POLLUTION DEGREE</b>	2, per IEC 61131-2	<b>MATERIAL COMPLIANCE</b>	Compliant with REACH

GENERAL DATA

<b>HOUSING MATERIAL</b>	PPE	<b>DIMENSIONS (H X W X D)</b>	110.6 x 15 x 78.4 mm
<b>WEIGHT</b>	63 g	<b>MTTF (25 °C)</b>	196 years
<b>COLOR</b>	Light gray	<b>APPROVALS</b>	CE

6.4.6.2. 4-channel temperature measurement module profile drawing

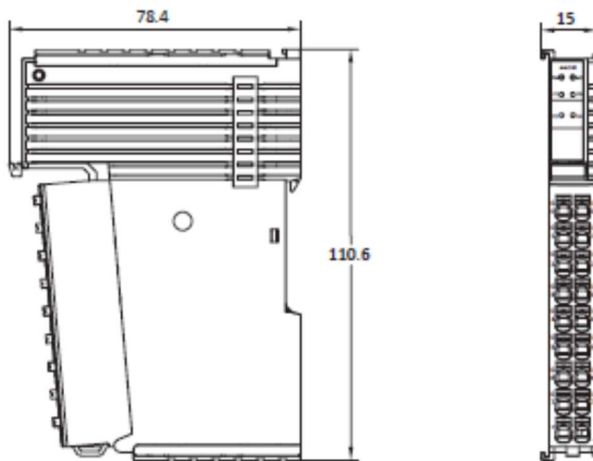

6.4.7. Auxiliary power module

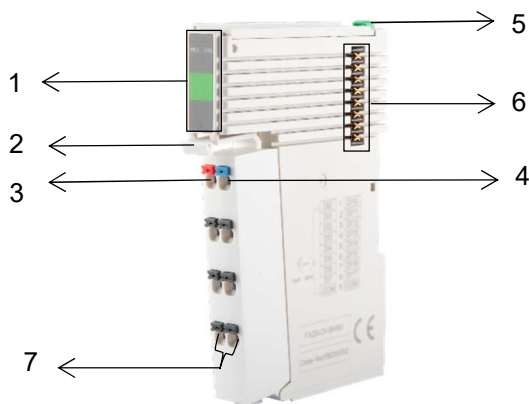

Item	Name	Function	Status
1	Module running indicators		
	PW	24 V power indicator	Green: normal Red: 24V overvoltage
	Us	Backplane power indicator	Green: normal Off: no power supply
2	Terminal disassembly device	Press the device to separate the terminal block from the module	-
3	External power supply terminal	24 V+	-
4	External power supply terminal	0 V	-
5	Module fixing device	Used to fix the module to the standard mounting rail	Pulling up: assembling position; Pressing down: locking position
6	Backplane bus interface	Backplane communication	-
7	Grounding terminal	PE	-

### 6.4.7.1. Auxiliary power module technical data

#### FX20-PS-AB00

#### ARTICLE PROPERTIES

<b>PRODUCT TYPE</b>	FX20 series modular I/O system auxiliary power supply module	<b>PRODUCT GROUP</b>	IP20 modular I/O system
<b>DESCRIPTION</b>	FX20-submodul power supply, 24 V DC, IP20, DIN rail installation, overcurrent and reverse polarity protection	<b>PU</b>	1 pc
		<b>COUNTRY OF ORIGIN</b>	CN

#### TECHNICAL DATA

<b>INPUT VOLTAGE</b>	24 V DC	<b>OUTPUT CURRENT</b>	Max. 3 A
<b>INPUT VOLTAGE RANGE</b>	20.4.....28.8 V DC	<b>POWER PROTECTION</b>	Overcurrent protection, power polarity reverse protection
<b>OUTPUT VOLTAGE</b>	5 V DC	<b>EFFICIENCY</b>	95%

#### CONNECTION DATA

<b>WIRE CONNECTION</b>	Plug-in terminal block	<b>STRIPPED LENGTHS</b>	8 ... 10 mm 0.315 ... 0.394 in
<b>CROSS SECTION</b>	0.08 mm <sup>2</sup> ... 2.5 mm <sup>2</sup> AWG 28 ... 14		

#### ENVIRONMENTAL REQUIREMENTS

<b>PROTECTION CLASS</b>	IP20	<b>ELECTRICAL FAST TRANSIENT (EFT)</b>	Level A, per IEC 61000-4-4
-------------------------	------	--	----------------------------

<b>MOUNTING TYPE</b>	DIN-35 mm rail	<b>ELECTRO-STATIC DISCHARGE (ESD)</b>	Level A, per IEC 61000-4-2
<b>AMBIENT TEMPERATURE</b>	-5 ... +60 °C	<b>SURGE TEST</b>	Level A, per IEC 61000-4-5
<b>STORAGE TEMPERATURE</b>	-25 ... +70 °C	<b>VIBRATION RESISTANCE</b>	4 g, per IEC 60068-2-6
<b>RELATIVE HUMIDITY</b>	95%, non-condensing	<b>SHOCK RESISTANCE</b>	15 g, per IEC 60068-2-27
<b>OPERATING ALTITUDE</b>	0 ... 2000 m / 0 ... 6562 ft	<b>EU ROHS COMPLIANCE STATUS</b>	Yes
<b>POLLUTION DEGREE</b>	2, per IEC 61131-2	<b>MATERIAL COMPLIANCE</b>	Compliant with REACH

GENERAL DATA

<b>HOUSING MATERIAL</b>	PPE	<b>DIMENSIONS (H X W X D)</b>	110.6 x 15 x 78.4 mm
<b>WEIGHT</b>	63 g	<b>APPROVALS</b>	CE
<b>COLOR</b>	Light gray		

6.4.7.2. Auxiliary power module profile drawing

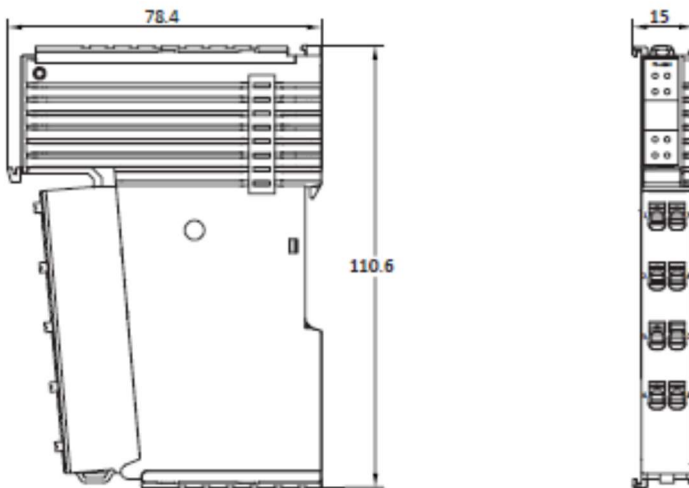

## 7. Mechanical installation and disassembly

### 7.1. Installation location and minimum installation distance

The installation position and reserved space are shown in the following figure. Install the installation guide rail horizontally to the designated installation position, and the connection surface of the connector and I/O modules must face forward.

The installation position should maintain a certain distance from adjacent electrical components or cabinets to facilitate heat dissipation. The recommended minimum installation clearance can refer to the markings in the above figure.

Ensure that FX20 is ventilated from bottom to top and achieve optimal cooling through convective ventilation.

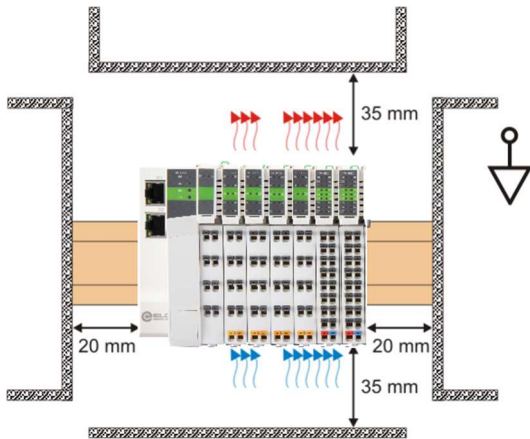

### 7.2. FX20 adapter installation

The installation is carried out according to the following steps:



During installation, align the module with the DIN rail and press the fixing device in the direction indicated by the arrow. After installation, there will be a noticeable clicking sound; change the position of the locking device slightly; after installing the module properly, make the locking device clamp the upper edge of the rail; to avoid damaging the product, do not apply excessive force.

### 7.3. I/O modules installation

After the installation of the adapter, the function modules can be sequentially inserted from the right side of the adapter. Before the insertion, ensure to pull out the fixing device and aligned with the two slots on the module.

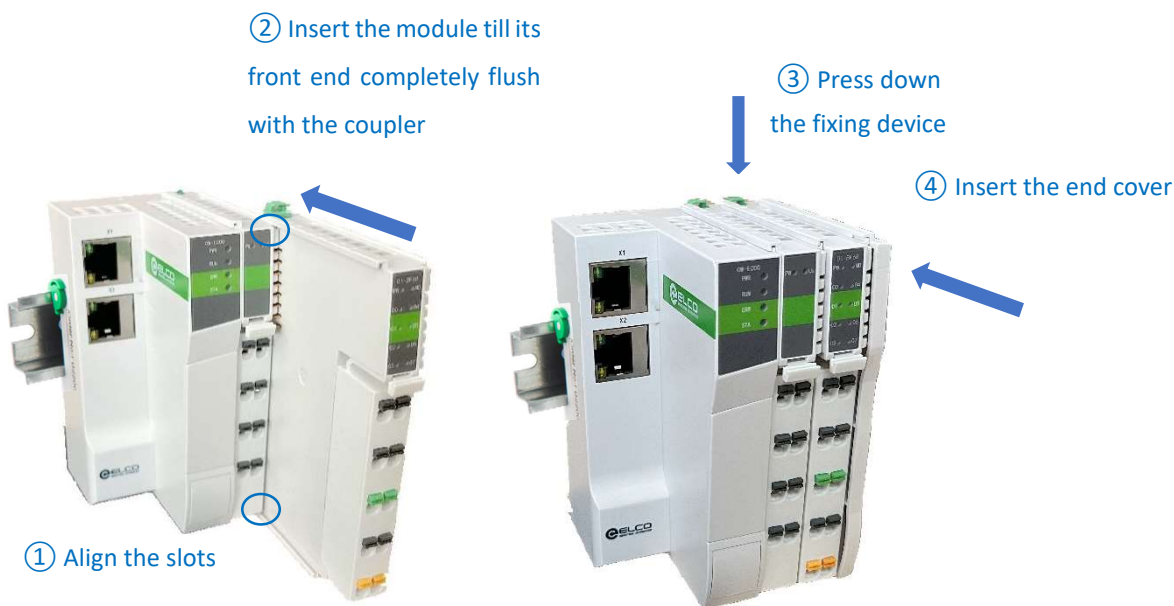

**i Caution!**

The end cover is only to protect the backplane bus interface of the end module, and it is packaged and shipped together with the adapter.

**7.4. Modules disassembly**

Use a flat screwdriver or similar tool to pry up the locking device on the rail, and then pull the module away from the DIN rail.



The wiring terminals of all modules can be removed separately to facilitate module replacement, as follows:

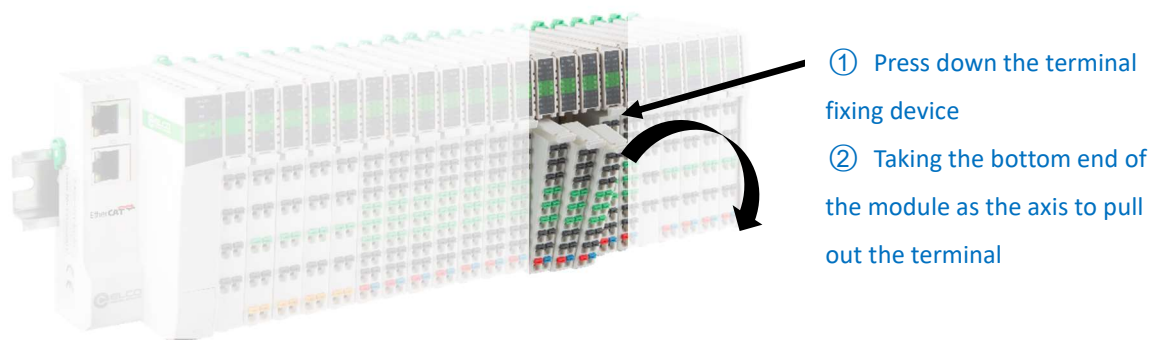

**Warning!** 

The mechanical installation and disassembly of modules require qualified professional mechanical personnel to operate and pay attention to the correct wearing and use of labor protection equipment.

## 8. Electrical installation and wiring

### 8.1. Cable specification

#### 8.1.1. Communication cable

EtherCAT bus communication uses shielded network cables for data transmission, without short circuits, misalignment, and poor contact; The length of the cable between devices cannot exceed 100m, as exceeding this length will cause signal attenuation and affect normal communication. The following specifications of communication cables are recommended:

Item	Specification
Cable type	Elastic crossover cable, S-FTP, category 5
Standards met	EIA/TIA568A,EN50173,ISO/IEC11801 EIA/TIA bulletin TSB,EIA/TIA SB40-A&TSB36
Conductor section	AWG26
Wire type	Twisted pair
Wire pair	4

Pre-wired connectors are better for communication and construction. Elco pre-wired connectors can provide customized cable material and cable length in accordance with communication technology requirements. The following Elco Ethernet connectors are available:

Model	Description
E16DA4002M020	RJ45-M12 double-ended pre-wired Ethernet connector, male straight, D-CODE, 4-pin, Cat5e, PVC, 2 M, fixed installation
E66D04002M020	RJ45-RJ45 double-ended pre-wired Ethernet connector, male straight-male straight, 4-pin, Cat5e, PVC, 2 M, fixed installation
E16DA4004M020	RJ45-M12 double-ended pre-wired Ethernet connector, male straight, D-CODE,4-pin, Cat5e, PVC, 2 M, suitable for drag chain
E66D04004M020	RJ45-RJ45 double-ended pre-wired Ethernet connector, male straight-male straight,4-pin, Cat5e, PUR,2 M, suitable for drag chain

**i** For more selection of Ethernet connectors, please refer to Elco's "Connectivity System Catalog".

#### 8.1.2. Power and signal cables

The FX20 series adopts tool-free spring wiring terminals, and the wiring needs to be equipped with tube type cold pressing cable lugs. Please refer to the following figure for the stripping length and cable lug specifications:

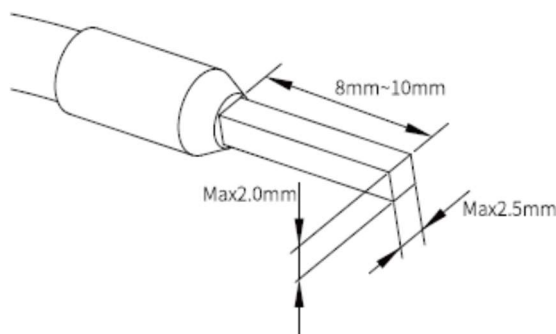

Standard cable crimper can be used for pressing the wire ear, as shown in the following figure:

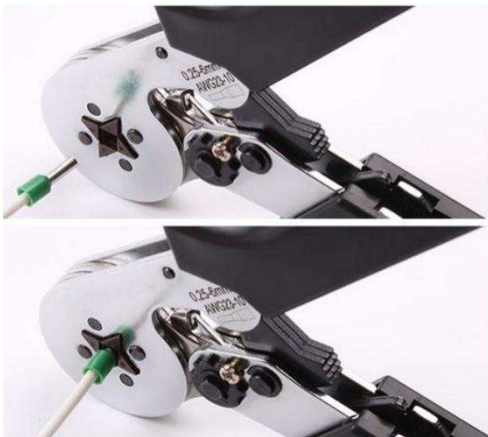

The wire connection does not need tools, and the wiring method is as follows:

- 1) Install the wire ear on the wire;
- 2) Insert the wire installed with the wire ear into the plug-in terminal to its most;
- 3) Pull the cable to ensure its fixed securely.

To release the wire:

- 1) Press the terminal spring button with your hand or a flat screwdriver
- 2) Pull out the wire and release the button.

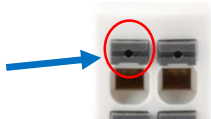

## 8.2. Modules wiring diagram

### 8.2.1. FX20 system power supply diagram

The FX20 series backplane 5 V DC power supply is provided by the adapter, and the load power supply for modules need to be provided separately. Additionally, an auxiliary power supply module can provide a larger backplane power supply current. Usually, when the number of modules exceeds 16 in FX20, the auxiliary power supply module should be considered.

The power supply system diagram is as follows:

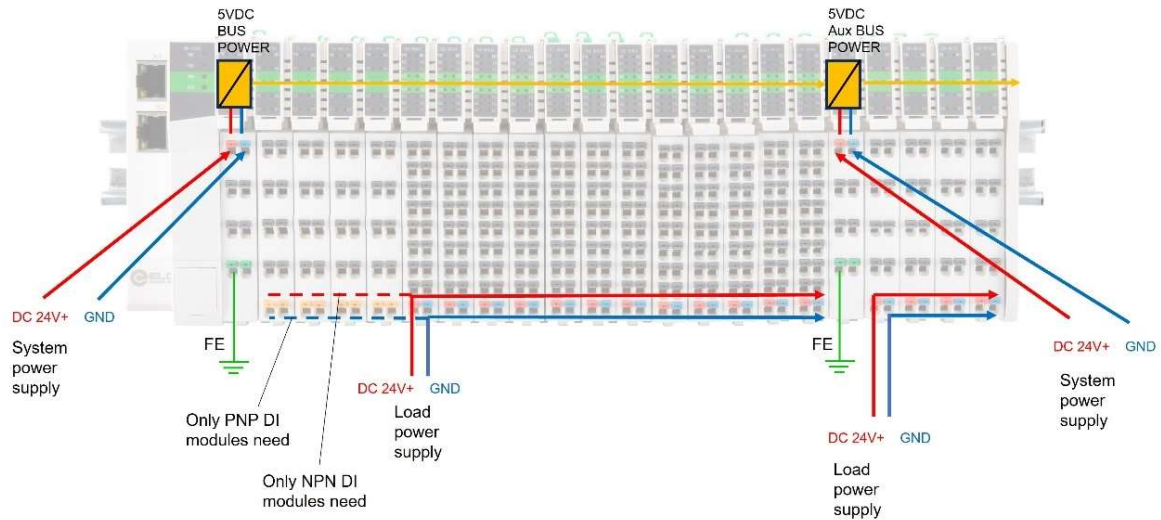

**Warning!**

- Be sure to disconnect all power connections before wiring!
- To ensure safety, must reliably connect the module grounding terminal to the ground!
- The wiring work must be operated by authorized electrical personnel to ensure safety!
- Using cables that do not meet the requirements will result in serious equipment damage or personal injury!
- Please refer to this manual or the wiring diagram printed on the side of the module for wiring. Incorrect wiring will cause module damage or personal injury!

### 8.2.2. EtherCAT bus adapter wiring diagram

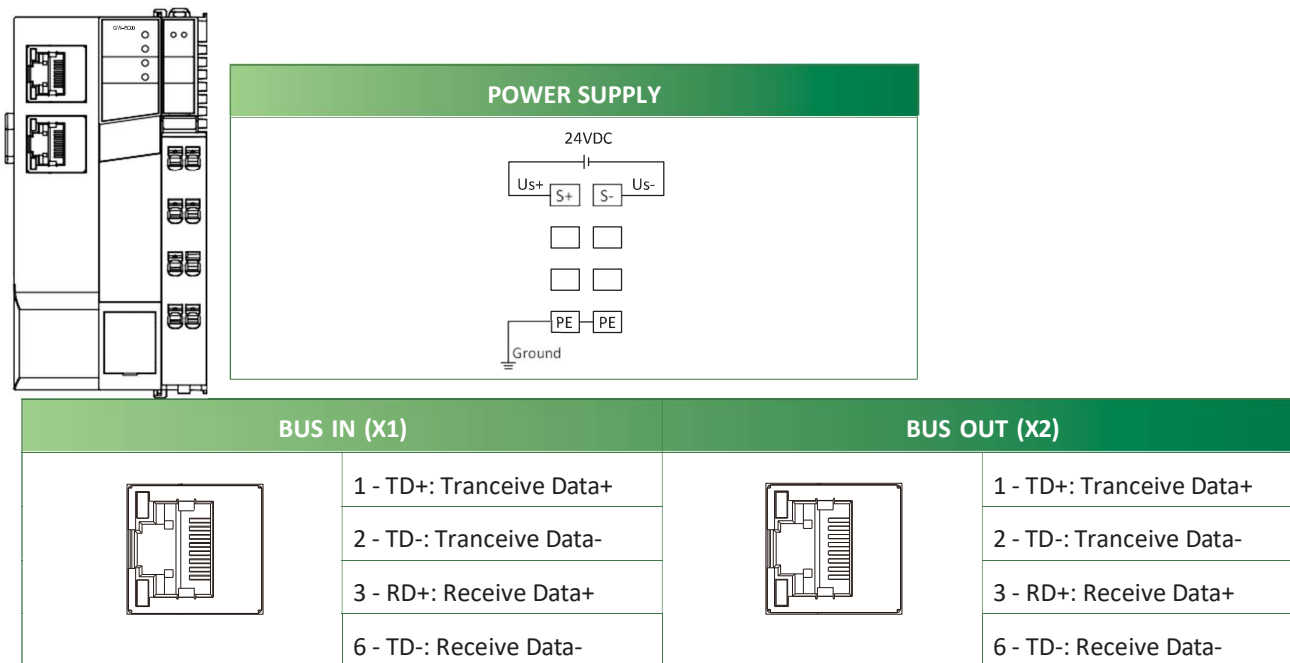

### 8.2.3. 8-channel DI module wiring diagram and I/O mapping

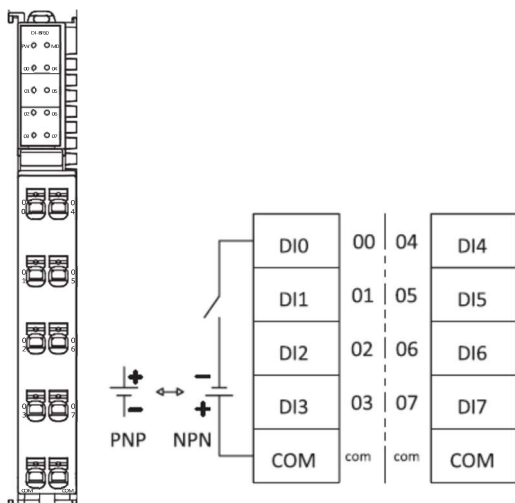

Model: FX20-DI-BF60

Input	Terminal No.	07	06	05	04	03	02	01	00
Byte 0	Address	I n.7	I n.6	I n.5	I n.4	I n.3	I n.2	I n.1	I n.0
	Byte 0	Bit 7	Bit 6	Bit 5	Bit 4	Bit 3	Bit 2	Bit 1	Bit 0

n: Starting byte of configuration

### 8.2.4. 8-channel DO PNP module wiring diagram and I/O mapping

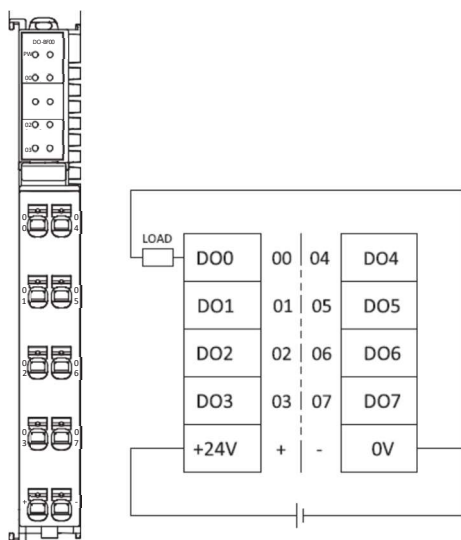

**Model: FX20-DO-BF00**

Output	Terminal No.	07	06	05	04	03	02	01	00
Byte 0	Address	Q n.7	Q n.6	Q n.5	Q n.4	Q n.3	Q n.2	Q n.1	Q n.0
	Byte 0	Bit 7	Bit 6	Bit 5	Bit 4	Bit 3	Bit 2	Bit 1	Bit 0

n: Starting byte of configuration

### 8.2.5. 8-channel DO NPN module wiring diagram and I/O mapping

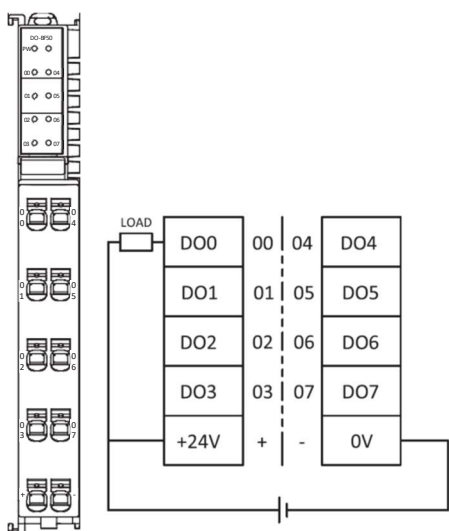

**Model: FX20-DO-BF50**

Output	Terminal No.	07	06	05	04	03	02	01	00
Byte 0	Address	Q n.7	Q n.6	Q n.5	Q n.4	Q n.3	Q n.2	Q n.1	Q n.0
	Byte 0	Bit 7	Bit 6	Bit 5	Bit 4	Bit 3	Bit 2	Bit 1	Bit 0

n: Starting byte of configuration

### 8.2.6. 4-channel SSR (AC) output module wiring diagram I/O mapping

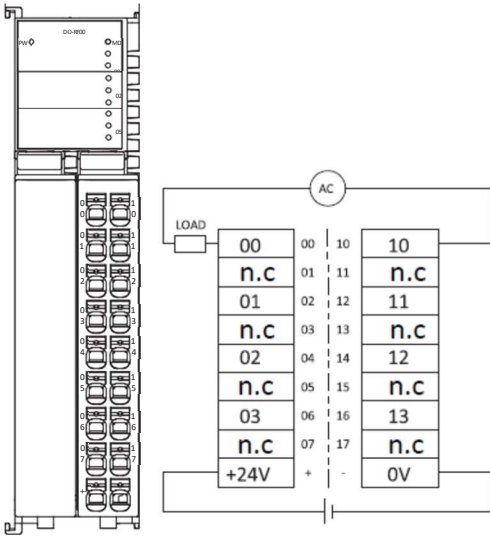

**Model: FX20-DO-RD00**

Output	Terminal No.	07	06	05	04	03	02	01	00
Byte 0	Address	-	-	-	-	Q n.3	Q n.2	Q n.1	Q n.0
	Byte 0	-	-	-	-	Bit 3	Bit 2	Bit 1	Bit 0
-	Terminal No.	17	16	15	14	13	12	11	10
-	Address	-	-	-	-	-	-	-	-

n: Starting byte of configuration

### 8.2.7. 8-channel relay output module wiring diagram and I/O mapping

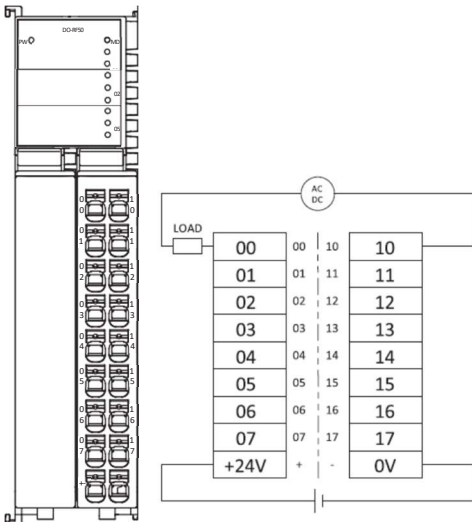

**Model: FX20-DO-RF50**

Output	Terminal No.	07	06	05	04	03	02	01	00
Byte 0	Address	Q n.7	Q n.6	Q n.5	Q n.4	Q n.3	Q n.2	Q n.1	Q n.0
	Byte 0	Bit 7	Bit 6	Bit 5	Bit 4	Bit 3	Bit 2	Bit 1	Bit 0
-	Terminal No.	17	16	15	14	13	12	11	10

Address	-	-	-	-	-	-	-	-
---------	---	---	---	---	---	---	---	---

n: Starting byte of configuration

### 8.2.8. 16-channel DI module wiring diagram and I/O mapping

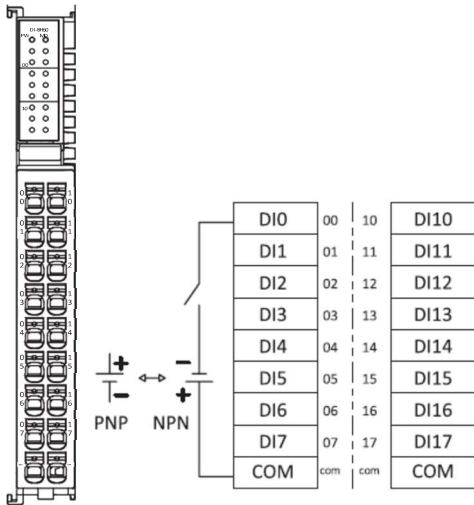

**Model: FX20-DI-BH60**

Input	Terminal No.	07	06	05	04	03	02	01	00
Byte 0	Address	I n.7	I n.6	I n.5	I n.4	I n.3	I n.2	I n.1	I n.0
	Byte 0	Bit 7	Bit 6	Bit 5	Bit 4	Bit 3	Bit 2	Bit 1	Bit 0
Input	Terminal No.	17	16	15	14	13	12	11	10
Byte 1	Address	I(n+1).7	I(n+1).6	I(n+1).5	I(n+1).4	I(n+1).3	I(n+1).2	I(n+1).1	I(n+1).0
	Byte 1	Bit 7	Bit 6	Bit 5	Bit 4	Bit 3	Bit 2	Bit 1	Bit 0

n: Starting byte of configuration

### 8.2.9. 16-channel DO PNP module wiring diagram and I/O mapping

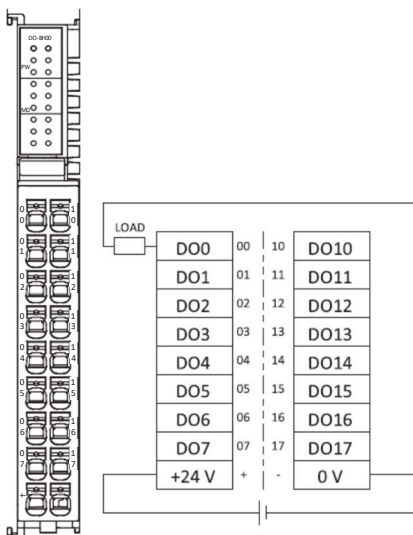

**Model: FX20-DO-BH00**

Output	Terminal No.	07	06	05	04	03	02	01	00
Byte 0	Address	Q n.7	Q n.6	Q n.5	Q n.4	Q n.3	Q n.2	Q n.1	Q n.0

	Byte 0	Bit 7	Bit 6	Bit 5	Bit 4	Bit 3	Bit 2	Bit 1	Bit 0
Output	Terminal No.	17	16	15	14	13	12	11	10
Byte 1	Address	Q(n+1).7	Q(n+1).6	Q(n+1).5	Q(n+1).4	Q(n+1).3	Q(n+1).2	Q(n+1).1	Q(n+1).0
	Byte 1	Bit 7	Bit 6	Bit 5	Bit 4	Bit 3	Bit 2	Bit 1	Bit 0

n: Starting byte of configuration

### 8.2.10. 16-channel DO NPN module wiring diagram and I/O mapping

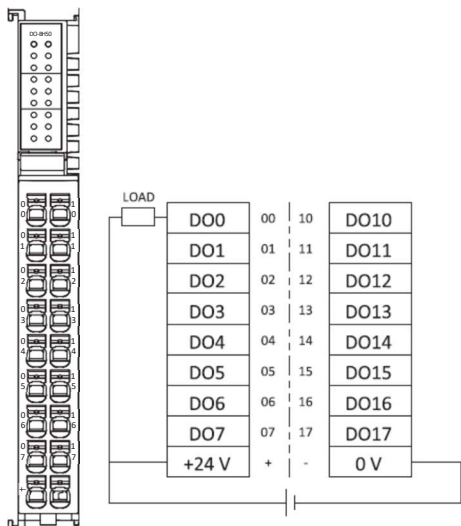

**Model: FX20-DO-BH50**

Output	Terminal No.	07	06	05	04	03	02	01	00
t	Address	Q n.7	Q n.6	Q n.5	Q n.4	Q n.3	Q n.2	Q n.1	Q n.0
	Byte 0	Byte 0	Bit 7	Bit 6	Bit 5	Bit 4	Bit 3	Bit 2	Bit 1
Output	Terminal No.	17	16	15	14	13	12	11	10
t	Address	Q(n+1).7	Q(n+1).6	Q(n+1).5	Q(n+1).4	Q(n+1).3	Q(n+1).2	Q(n+1).1	Q(n+1).0
	Byte 1	Byte 1	Bit 7	Bit 6	Bit 5	Bit 4	Bit 3	Bit 2	Bit 1

n: Starting byte of configuration

### 8.2.11. 32-channel DI module wiring diagram and I/O mapping

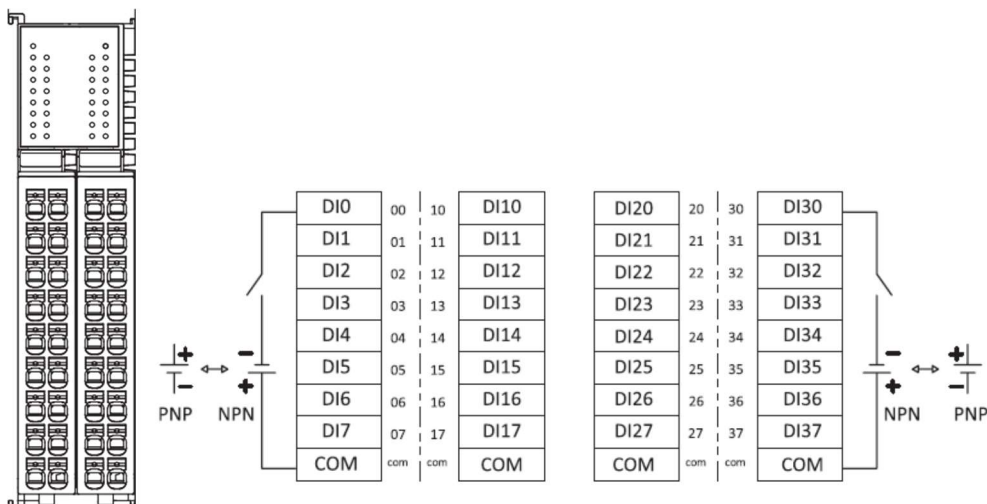

**Model: FX20-DI-BL60**

Input	Terminal No.	07	06	05	04	03	02	01	00
Byte 0	Address	I n.7	I n.6	I n.5	I n.4	I n.3	I n.2	I n.1	I n.0
	Byte 0	Bit 7	Bit 6	Bit 5	Bit 4	Bit 3	Bit 2	Bit 1	Bit 0
Input	Terminal No.	17	16	15	14	13	12	11	10
Byte 1	Address	I(n+1).7	I(n+1).6	I(n+1).5	I(n+1).4	I(n+1).3	I(n+1).2	I(n+1).1	I(n+1).0
	Byte 1	Bit 7	Bit 6	Bit 5	Bit 4	Bit 3	Bit 2	Bit 1	Bit 0
Input	Terminal No.	27	26	25	24	23	22	21	20
Byte 2	Address	I(n+2).7	I(n+2).6	I(n+2).5	I(n+2).4	I(n+2).3	I(n+2).2	I(n+2).1	I(n+2).0
	Byte 2	Bit 7	Bit 6	Bit 5	Bit 4	Bit 3	Bit 2	Bit 1	Bit 0
Input	Terminal No.	37	36	35	34	33	32	31	30
Byte 3	Address	I(n+3).7	I(n+3).6	I(n+3).5	I(n+3).4	I(n+3).3	I(n+3).2	I(n+3).1	I(n+3).0
	Byte 3	Bit 7	Bit 6	Bit 5	Bit 4	Bit 3	Bit 2	Bit 1	Bit 0

n: Starting byte of configuration

8.2.12. 32-channel DO PNP module wiring diagram and I/O mapping

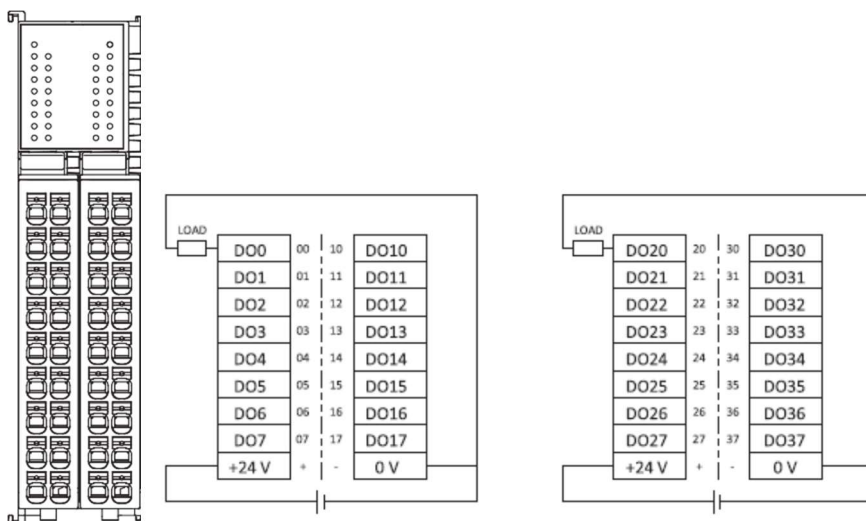

**Model: FX20-DO-BL00**

Output	Terminal No.	07	06	05	04	03	02	01	00
Byte 0	Address	Q n.7	Q n.6	Q n.5	Q n.4	Q n.3	Q n.2	Q n.1	Q n.0
	Byte 0	Bit 7	Bit 6	Bit 5	Bit 4	Bit 3	Bit 2	Bit 1	Bit 0
Output	Terminal No.	17	16	15	14	13	12	11	10
Byte 1	Address	Q(n+1).7	Q(n+1).6	Q(n+1).5	Q(n+1).4	Q(n+1).3	Q(n+1).2	Q(n+1).1	Q(n+1).0
	Byte 1	Bit 7	Bit 6	Bit 5	Bit 4	Bit 3	Bit 2	Bit 1	Bit 0
Output	Terminal No.	27	26	25	24	23	22	21	20
Byte 2	Address	Q(n+2).7	Q(n+2).6	Q(n+2).5	Q(n+2).4	Q(n+2).3	Q(n+2).2	Q(n+2).1	Q(n+2).0
	Byte 2	Bit 7	Bit 6	Bit 5	Bit 4	Bit 3	Bit 2	Bit 1	Bit 0
Output	Terminal No.	37	36	35	34	33	32	31	30
Byte 3	Address	Q(n+3).7	Q(n+3).6	Q(n+3).5	Q(n+3).4	Q(n+3).3	Q(n+3).2	Q(n+3).1	Q(n+3).0
	Byte 3	Bit 7	Bit 6	Bit 5	Bit 4	Bit 3	Bit 2	Bit 1	Bit 0

n: Starting byte of configuration

### 8.2.13. 32-channel DO NPN module wiring diagram and I/O mapping

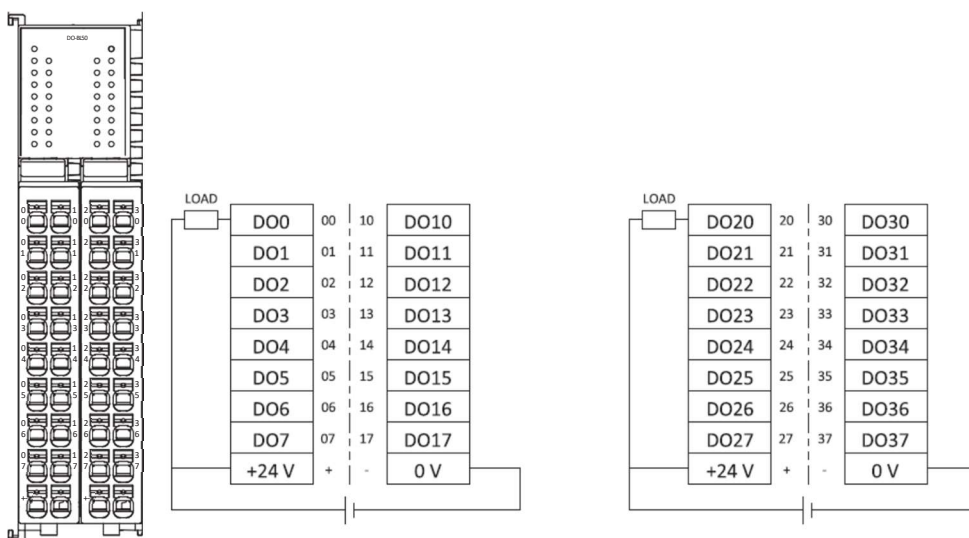

**Model: FX20-DO-BL50**

Output	Terminal No.	07	06	05	04	03	02	01	00
Byte 0	Address	Q n.7	Q n.6	Q n.5	Q n.4	Q n.3	Q n.2	Q n.1	Q n.0
	Byte 0	Bit 7	Bit 6	Bit 5	Bit 4	Bit 3	Bit 2	Bit 1	Bit 0
Output	Terminal No.	17	16	15	14	13	12	11	10
Byte 1	Address	Q(n+1).7	Q(n+1).6	Q (n+1).5	Q(n+1).4	Q(n+1).3	Q (n+1).2	Q (n+1).1	Q (n+1).0
	Byte 1	Bit 7	Bit 6	Bit 5	Bit 4	Bit 3	Bit 2	Bit 1	Bit 0
Output	Terminal No.	27	26	25	24	23	22	21	20
Byte 2	Address	Q(n+2).7	Q(n+2).6	Q (n+2).5	Q(n+2).4	Q(n+2).3	Q (n+2).2	Q (n+2).1	Q (n+2).0
	Byte 2	Bit 7	Bit 6	Bit 5	Bit 4	Bit 3	Bit 2	Bit 1	Bit 0
Output	Terminal No.	37	36	35	34	33	32	31	30
Byte 3	Address	Q(n+3).7	Q(n+3).6	Q (n+3).5	Q(n+3).4	Q(n+3).3	Q (n+3).2	Q (n+3).1	Q (n+3).0
	Byte 3	Bit 7	Bit 6	Bit 5	Bit 4	Bit 3	Bit 2	Bit 1	Bit 0

n: Starting byte of configuration

### 8.2.14. 4-channel AI module wiring diagram and I/O mapping

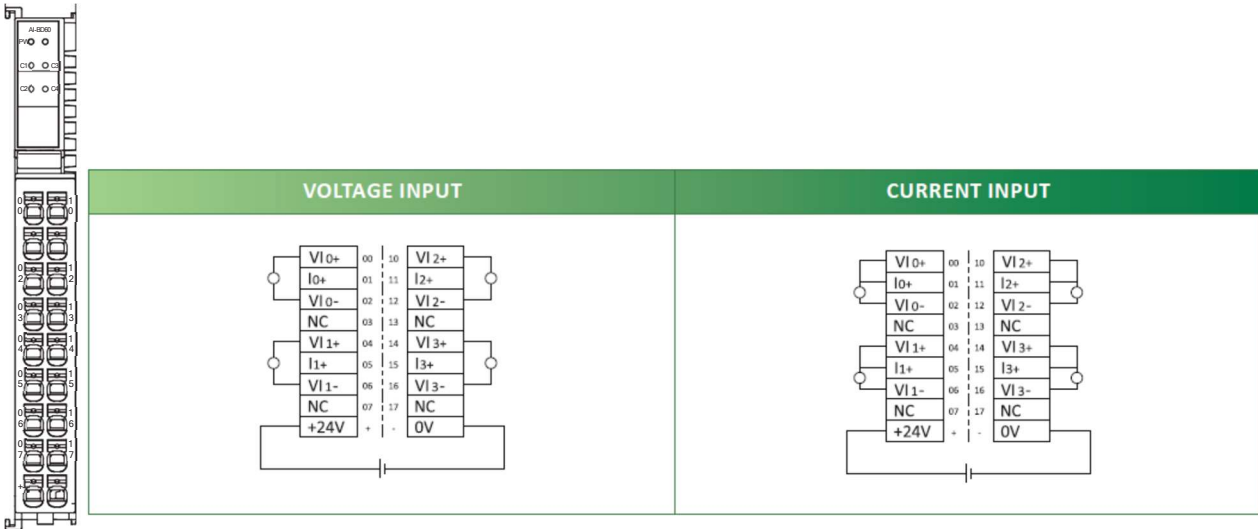

Model: FX20-AI-BD60								
Terminal No.	07	06	05	04	03	02	01	00
Address	IW n+2				IW n			
Channel	Channel 1				Channel 0			
Terminal No.	17	16	15	14	13	12	11	10
Address	IW n+6				IW n+4			
Channel	Channel 3				Channel 2			
n: Starting byte of configuration								

### 8.2.15. 4-channel AO module wiring diagram and I/O mapping

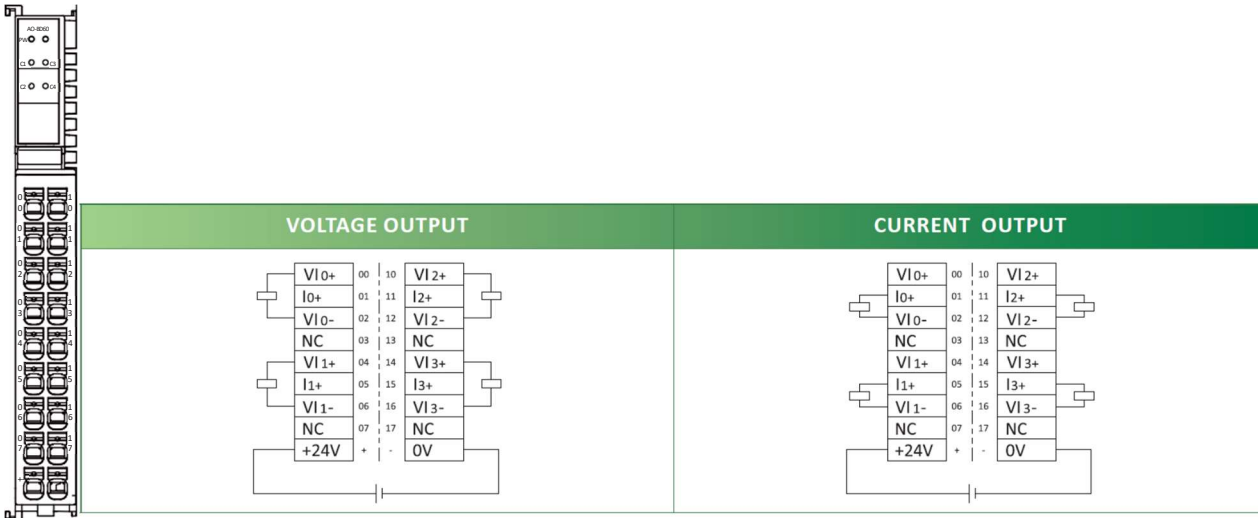

**Model: FX20-AO-BD60**

Terminal No.	07	06	05	04	03	02	01	00
Address	QW n+2				QW n			
Channel	Channel 1				Channel 0			
Terminal No.	17	16	15	14	13	12	11	10
Address	QW n+6				QW n+4			
Channel	Channel 3				Channel 2			

n: Starting byte of configuration

**8.2.16. 8-channel AI module wiring diagram and I/O mapping**

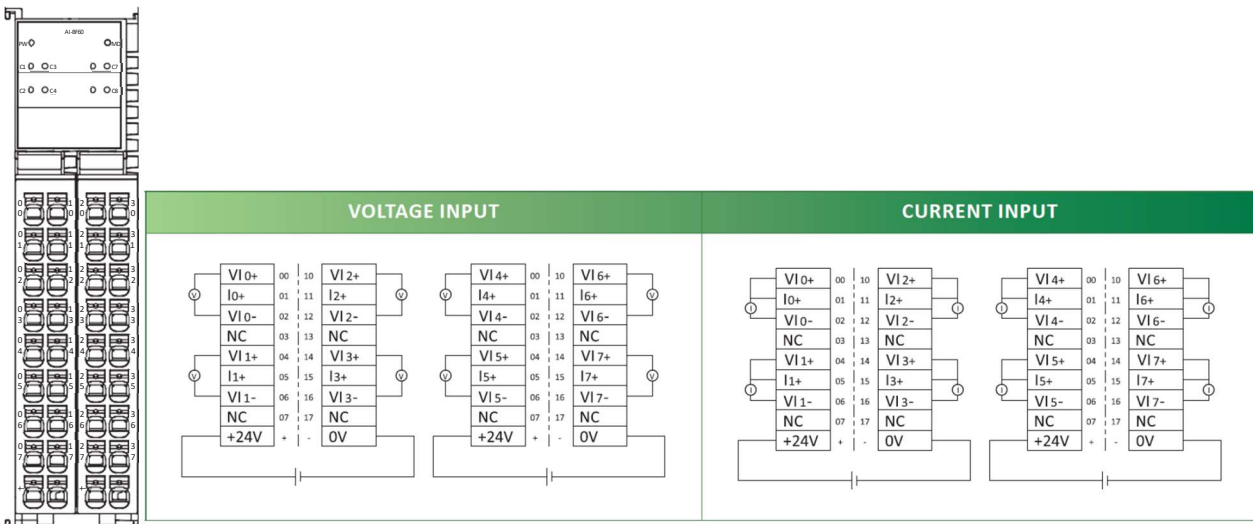

**Model: FX20-AI-BF60**

Terminal No.	07	06	05	04	03	02	01	00
Address	IW n+2				IW n			
Channel	Channel 1				Channel 0			
Terminal No.	17	16	15	14	13	12	11	10
Address	IW n+6				IW n+4			
Channel	Channel 3				Channel 2			
Terminal No.	27	26	25	24	23	22	21	20
Address	IW n+10				IW n+8			
Channel	Channel 5				Channel 4			
Terminal No.	37	36	35	34	33	32	31	30
Address	IW n+14				IW n+12			
Channel	Channel 7				Channel 6			

n: Starting byte of configuration

### 8.2.17. 8-channel AO module wiring diagram and I/O mapping

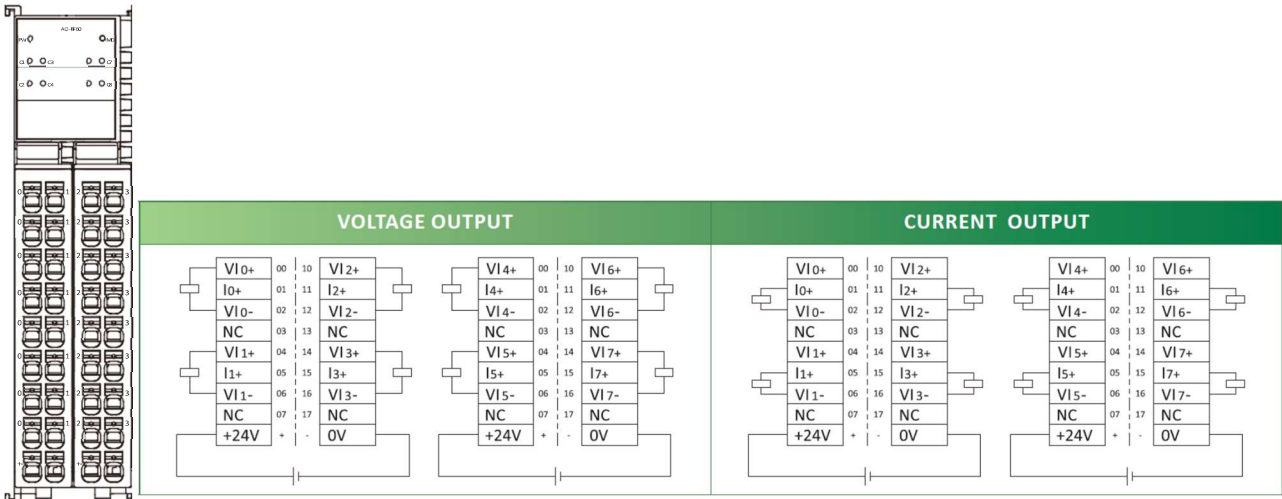

Model: FX20-AO-BF60								
Terminal No.	07	06	05	04	03	02	01	00
Address	QW n+2				QW n			
Channel	Channel 1				Channel 0			
Terminal No.	17	16	15	14	13	12	11	10
Address	QW n+6				QW n+4			
Channel	Channel 3				Channel 2			
Terminal No.	27	26	25	24	23	22	21	20
Address	QW n+10				QW n+8			
Channel	Channel 5				Channel 4			
Terminal No.	37	36	35	34	33	32	31	30
Address	QW n+14				QW n+12			
Channel	Channel 7				Channel 6			
n: Starting byte of configuration								

### 8.2.18. 4-channel RTD module wiring diagram and I/O mapping

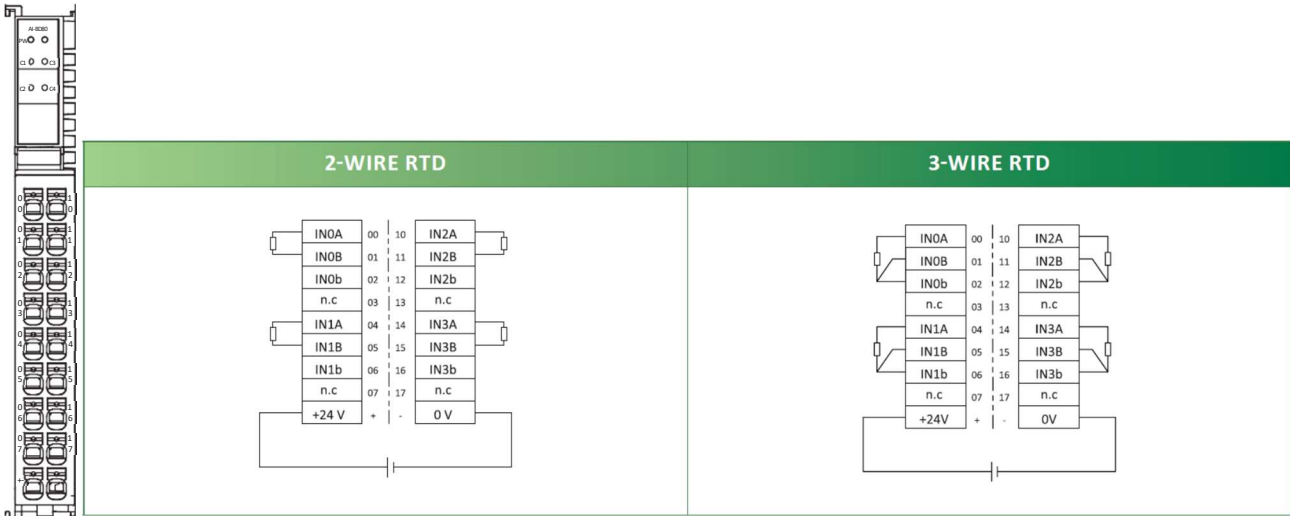

**Model: FX20-AI-BD80**

Terminal No.	07	06	05	04	03	02	01	00
Address	IW n+2				IW n			
Channel	Channel 1				Channel 0			
Terminal No.	17	16	15	14	13	12	11	10
Address	IW n+6				IW n+4			
Channel	Channel 3				Channel 2			

n: Starting byte of configuration

### 8.2.19. 4-channel TC module wiring diagram and I/O mapping

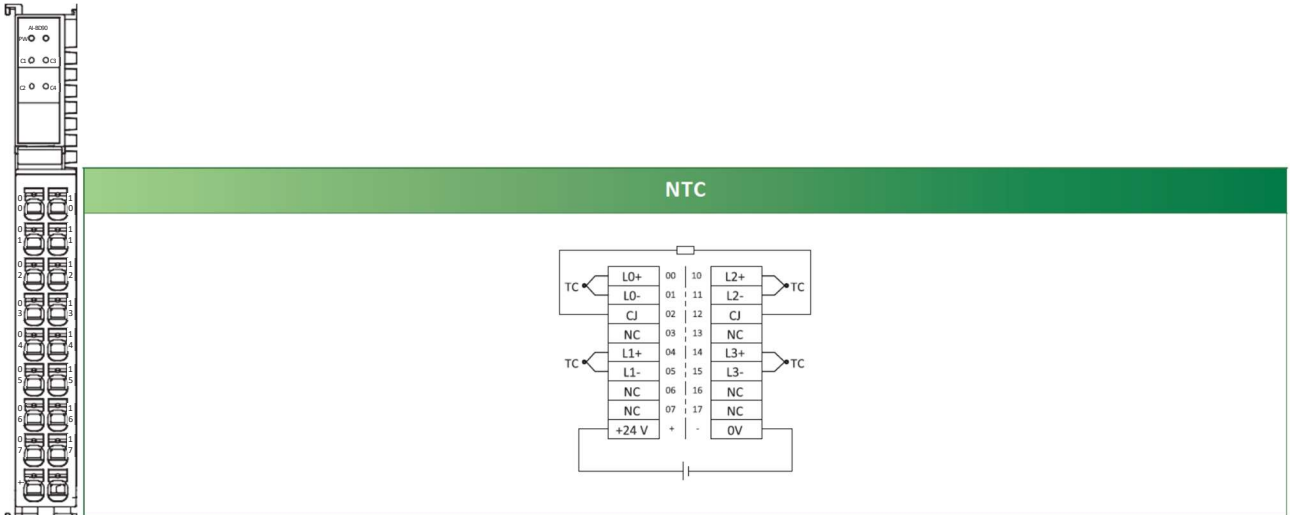

**Model: FX20-AI-BD90**

Terminal No.	07	06	05	04	03	02	01	00
Address	IW n+2				IW n			
Channel	Channel 1				Channel 0			
Terminal No.	17	16	15	14	13	12	11	10
Address	IW n+6				IW n+4			

Channel	Channel 3	Channel 2
n: Starting byte of configuration		

**8.2.20. Auxiliary power module wiring diagram**

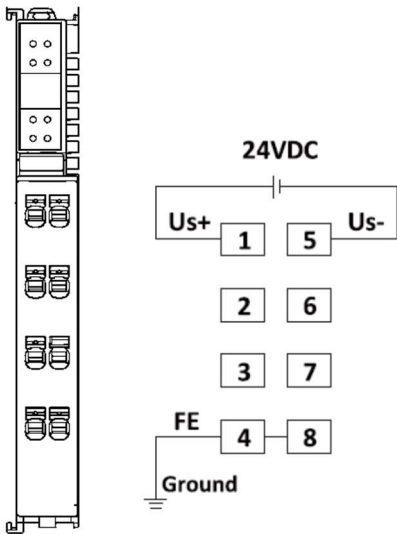

**Warning!**

- Module wiring diagrams are printed on the side of the module for easy reference during wiring and debugging.
- Only electrical technicians can carry out wiring and related operations.

## 9. Configuration and test

### 9.1. ESI file

Configure the FX20 series modules using an ESI file (in ".xml" format), which is used to integrate the FX20 series modules into your system as a standard EtherCAT slave. You can visit Elco website to obtain the latest XML files or call the customer service hotline to contact technical personnel.

Integrating ESI file into the system depends on the configuration software you are using.

### 9.2. FX20 EtherCAT bus adapter I/O mapping

The FX20 EtherCAT bus adapter occupies 8 bytes of input, of which the first 4 bytes are used for diagnostic information of the I/O modules, and the last 4 bytes are used for the connection status of the adapter I/O modules. The output of 4 bytes is reserved. The details are shown in the table below:

		Bit 7	Bit 6	Bit 5	Bit 4	Bit 3	Bit 2	Bit 1	Bit 0
Input Byte 0	Diagnosis of module 0	Slot8_Diag.	Slot7_Diag.	Slot6_Diag.	Slot5_Diag.	Slot4_Diag.	Slot3_Diag.	Slot2_Diag.	Slot1_Diag.
Input Byte 1	Diagnosis of module 1	Slot16_Diag.	Slot15_Diag.	Slot14_Diag.	Slot13_Diag.	Slot12_Diag.	Slot11_Diag.	Slot10_Diag.	Slot9_Diag.
Input Byte 2	Diagnosis of module 2	Slot24_Diag.	Slot23_Diag.	Slot22_Diag.	Slot21_Diag.	Slot20_Diag.	Slot19_Diag.	Slot18_Diag.	Slot17_Diag.
Input Byte 3	Diagnosis of module 3	Slot32_Diag.	Slot31_Diag.	Slot30_Diag.	Slot29_Diag.	Slot28_Diag.	Slot27_Diag.	Slot26_Diag.	Slot25_Diag.
Input Byte 4	Connection of module 0	Slot8_Conn.	Slot7_Conn.	Slot6_Conn.	Slot5_Conn.	Slot4_Conn.	Slot3_Conn.	Slot2_Conn.	Slot1_Conn.
Input Byte 5	Connection of module 1	Slot16_Conn.	Slot15_Conn.	Slot14_Conn.	Slot13_Conn.	Slot12_Conn.	Slot11_Conn.	Slot10_Conn.	Slot9_Conn.
Input Byte 6	Connection of module 2	Slot24_Conn.	Slot23_Conn.	Slot22_Conn.	Slot21_Conn.	Slot20_Conn.	Slot19_Conn.	Slot18_Conn.	Slot17_Conn.
Input Byte 7	Connection of module 3	Slot32_Conn.	Slot31_Conn.	Slot30_Conn.	Slot29_Conn.	Slot28_Conn.	Slot27_Conn.	Slot26_Conn.	Slot25_Conn.
Output Byte 0 to Byte 3	Reserved bytes								

In different PLC configuration software, the representation of bus adapter I/O mapping is slightly different, but the number of bytes occupied is the same.

The following is the I/O mapping of bus adapter in Omron Sysmac Studio:

FX20-GW-EC00			
▶ Port Digital Output_Digital Output_7800_01	ARRAY[0..31] OF BOOL		W
▶ Status of Slot_Diagnosis of Module_6800_01	ARRAY[0..31] OF BOOL		R
▶ Status of Slot_Connection of Module_6800_02	ARRAY[0..31] OF BOOL		R

In the PLC configuration software of the CODESYS core, the I/O mapping of the bus adapter looks like this:

Digital Output 0	%QB1	USINT		Digital Output 0	Reserved
Digital Output 1	%QB2	USINT		Digital Output 1	
Digital Output 2	%QB3	USINT		Digital Output 2	
Digital Output 3	%QB4	USINT		Digital Output 3	
Diagnosis of Module 0	%IB2	USINT		Diagnosis of Module 0	Diagnosis of each module
Diagnosis of Module 1	%IB3	USINT		Diagnosis of Module 1	
Diagnosis of Module 2	%IB4	USINT		Diagnosis of Module 2	
Diagnosis of Module 3	%IB5	USINT		Diagnosis of Module 3	
Connection of Module 0	%IB6	USINT		Connection of Module 0	Connection status of each module
Connection of Module 1	%IB7	USINT		Connection of Module 1	
Connection of Module 2	%IB8	USINT		Connection of Module 2	
Connection of Module 3	%IB9	USINT		Connection of Module 3	

### 9.3. FX20 Configuration Examples

#### 9.3.1. Configuration steps in Omron Sysmac Studio

This example uses Elco's FX20 series distributed I/O as the EtherCAT slave station to connect to Omron's controller with EtherCAT interface. By default, Sysmac Studio has been installed on the PC and the required network card information has been set, the FX20 series ESI file has been installed, and all power and bus connections have been completed.

Please refer to the Sysmac Studio user manual for the above operation process.

Take the following FX20 modules as a configuration example:

Model	Description	Quantity
FX20-GW-EC00	EtherCAT bus adapter	1
FX20-DI-BH60	16-channel digital input module, PNP/NPN	1
FX20-DO-BH00	16-channel digital output module, PNP	1
FX20-AI-BD60	4-channel analog input module	1
FX20-AO-BD60	4-channel analog output module	1

The configuration process for FX20 with the Omron Sysmac Studio is as follows:

- 9.3.1.1. Open the Sysmac Studio software and click on "New Project". Fill in the information based on the PLC model and click "Create".

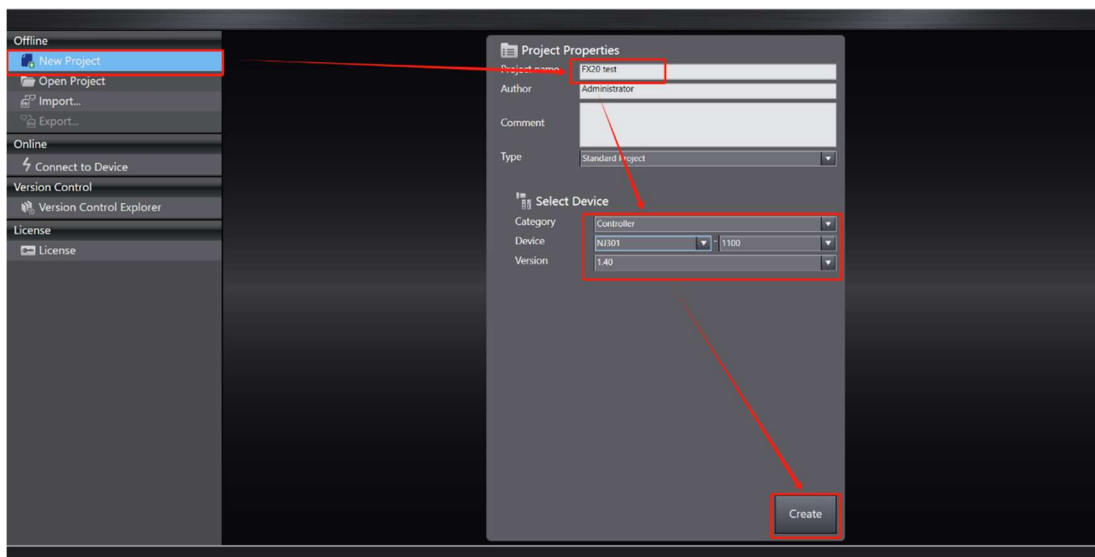

- 9.3.1.2. Double click "EtherCAT" from the "Configurations and Setup" list on the left, and the corresponding controller icon can be seen at main interface.

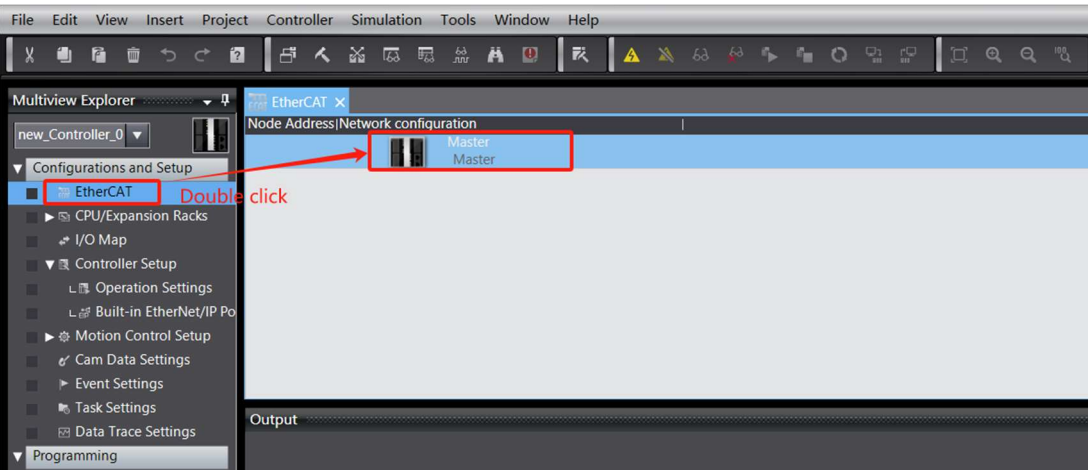

9.3.1.3. Right click on 'Master Device' and select 'Show ESI Library' from the pop-up list. In the newly opened window interface, click the "Install (File)" button, manually select the file storage path, choose the correct ESI file, click the "Open" button, and wait for the ESI file installation to complete.

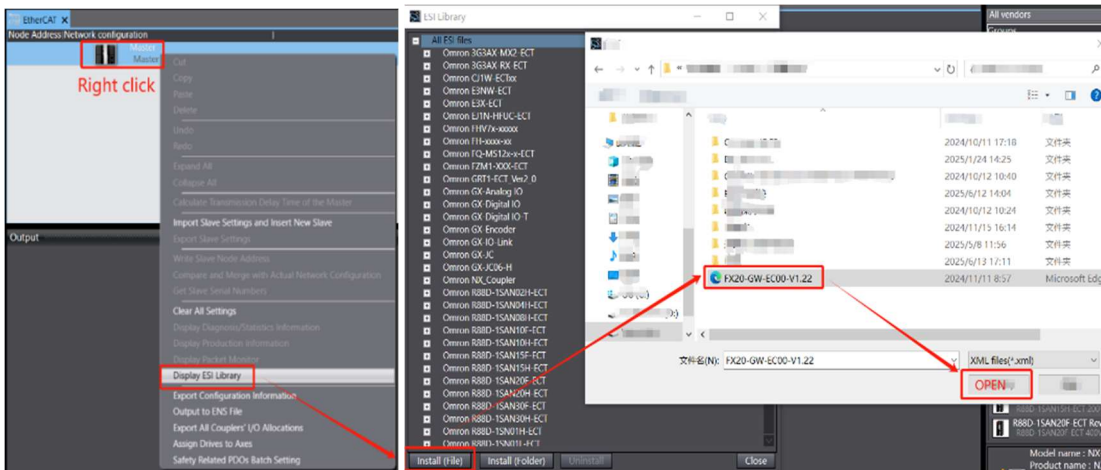

9.3.1.4. In the "Toolbox" list on the right, find "Flexy20 Master" and drag or double click the module "FX20-GW-EC00", below onto the main device. The system will assign EtherCAT node addresses based on the connection order (which can also be modified as needed).

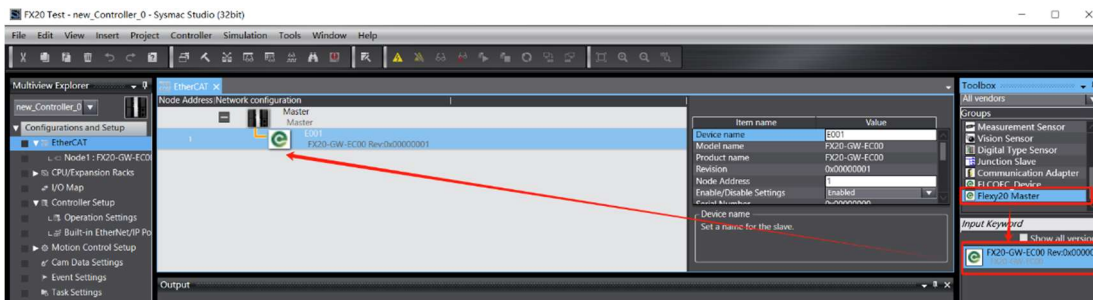

9.3.1.5. After configuring the adapter, continue configuring the I/O modules connected to the adapter. Right-click on the FX20-GW-EC00 and select "Edit Module Configuration" to open the editing interface of the FX20 module.

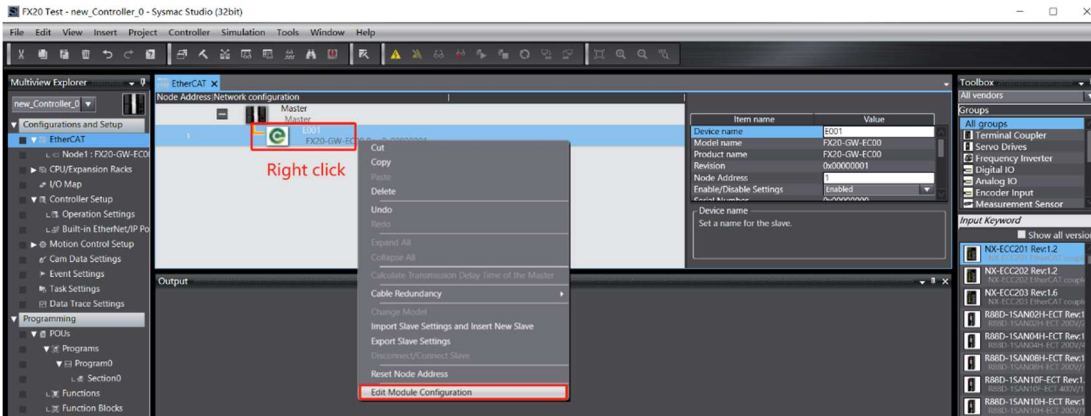

9.3.1.6. In the module configuration interface, drag the modules to the slots corresponding to FX20-GW-EC00 according to the actual connection order of the I/O modules.

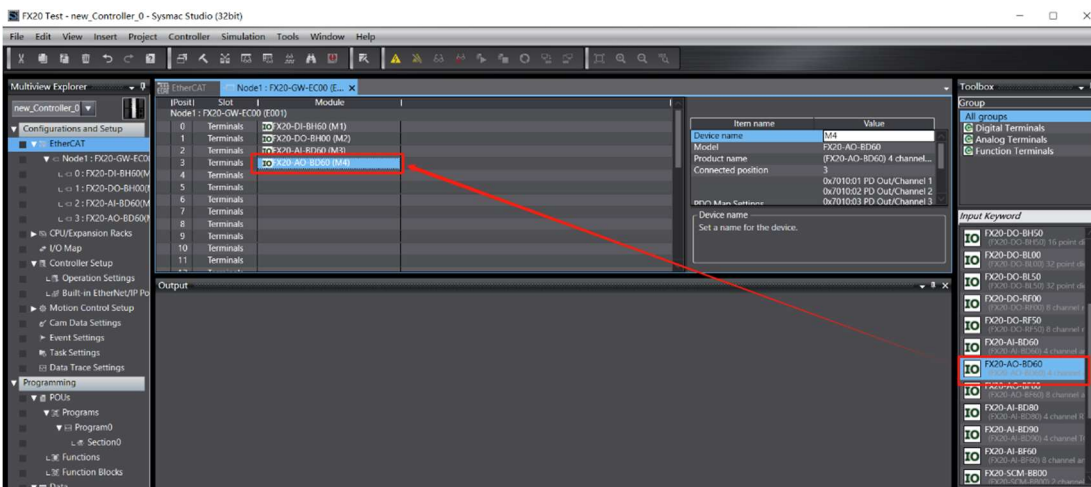

9.3.1.7. After configuring the I/O module, click on the "FX20-GW-EC00" adapter and select "Send" from the "Module Config Send method" option.

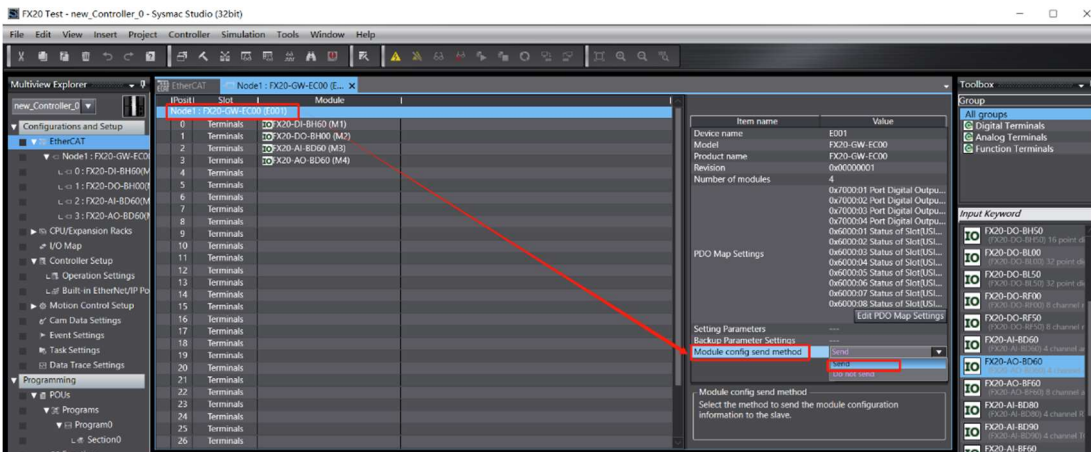

9.3.1.8. The analog modules need to select the corresponding range, filtering level, channel diagnosis function disable/enable, etc. Select FX20-AI-BD60, click "Edit setting parameters" in the right menu.

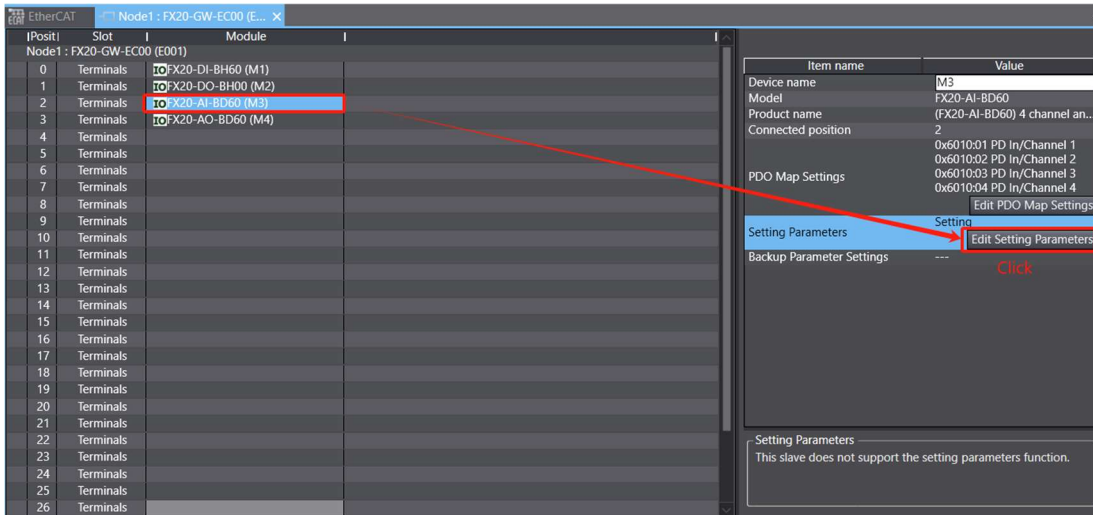

9.3.1.9. By default, the data processing type of the analog module is "little endian", which can also be changed to "big endian" according to the PLC processing method. All channels of the analog signal are inactive. Based on the actual connection signal type, click to select the range, signal type, filtering strength, and whether to add diagnostic data. Settings completed, click "OK" to exit.

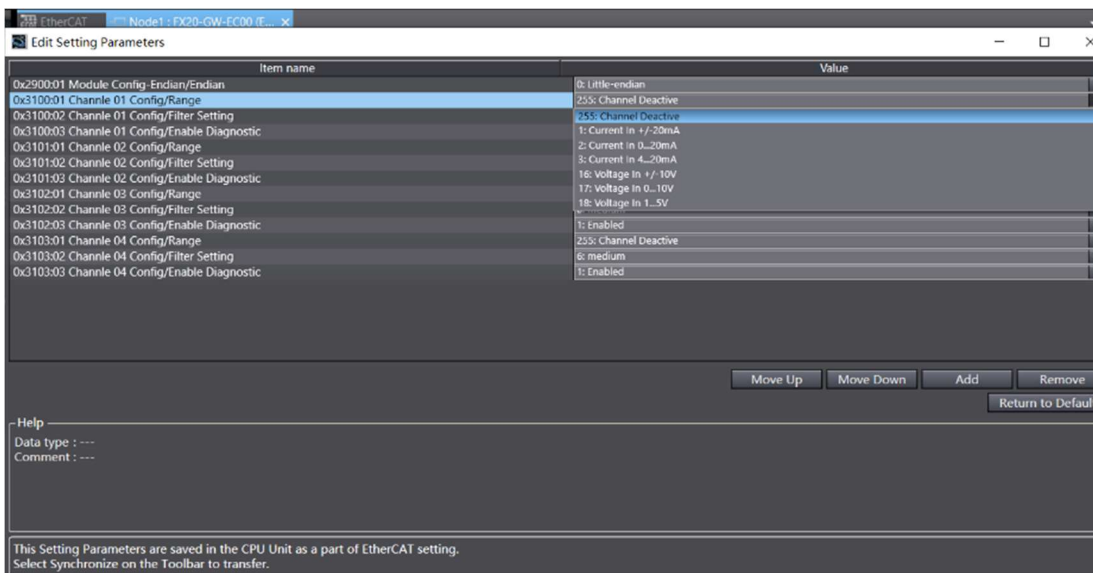

9.3.1.10. Double clicks on "I/O Mapping" in the "Configurations and Setup" list on the left to open the I/O Mapping Configuration interface. Here you can see the signals and statuses related to the FX20 modules, including the reserved bytes for the FX20 adapter, the diagnostic status of the corresponding slot of the I/O modules, and the connection status of the corresponding slot of the I/O modules.

Position	Port	Description	R/W	Data Type	Variable	Variable Comment	Variable Type
Node1	EtherCAT Network Configuration						
		FX20-GW-EC00					
		Port Digital Output(USINT)_Digital Output 0_7000_01	W	USINT			
		Port Digital Output(USINT)_Digital Output 1_7000_02	W	USINT			
		Port Digital Output(USINT)_Digital Output 2_7000_03	W	USINT			
		Port Digital Output(USINT)_Digital Output 3_7000_04	W	USINT			
		Status of Slot(USINT)_Diagnosis of Module 0_6000_01	R	USINT			
		Status of Slot(USINT)_Diagnosis of Module 1_6000_02	R	USINT			
		Status of Slot(USINT)_Diagnosis of Module 2_6000_03	R	USINT			
		Status of Slot(USINT)_Diagnosis of Module 3_6000_04	R	USINT			
	Status of Slot(USINT)_Connection of Module 0_6000_05	R	USINT				
	Status of Slot(USINT)_Connection of Module 1_6000_06	R	USINT				
	Status of Slot(USINT)_Connection of Module 2_6000_07	R	USINT				
	Status of Slot(USINT)_Connection of Module 3_6000_08	R	USINT				
Slot 0	FX20-DI-BH60						
	PD In(USINT)_Input Byte 0_6010_01	R	USINT				
	PD In(USINT)_Input Byte 1_6010_02	R	USINT				
Slot 1	FX20-DO-BH00						
	PD Out(USINT)_Output Byte 0_7010_01	W	USINT				
	PD Out(USINT)_Output Byte 1_7010_02	W	USINT				
Slot 2	FX20-AI-BD60						
	PD In_Channel 1_6010_01	R	INT				
	PD In_Channel 2_6010_02	R	INT				
	PD In_Channel 3_6010_03	R	INT				
	PD In_Channel 4_6010_04	R	INT				
Slot 3	FX20-AO-BD60						
	PD Out_Channel 1_7010_01	W	INT				
	PD Out_Channel 2_7010_02	W	INT				
	PD Out_Channel 3_7010_03	W	INT				
	PD Out_Channel 4_7010_04	W	INT				

9.3.1.11. In this interface, various variables for this FX20 module can be automatically generated by right-clicking on the module model and selecting "Create New Device Variable". Users can also manually fill in the variables as needed.

Variable	Data Type	Variable Comment	Variable Type
E001_Port_Digital	Global Variables		
E001_Port_Digital	Global Variables		
E001_Port_Digital	Global Variables		
E001_Port_Digital	Global Variables		
E001_Status_of_Sl	Global Variables		
E001_Status_of_Sl	Global Variables		
E001_Status_of_Sl	Global Variables		
E001_Status_of_Sl	Global Variables		
E001_Status_of_Sl	Global Variables		
E001_Status_of_Sl	Global Variables		
E001_Status_of_Sl	Global Variables		
M1_PD_In_USINT	Global Variables		
M1_PD_In_USINT	Global Variables		
M2_PD_Out_USIN	Global Variables		
M2_PD_Out_USIN	Global Variables		
M3_PD_In_Chann	Global Variables		
M3_PD_In_Chann	Global Variables		
M3_PD_In_Chann	Global Variables		
M3_PD_In_Chann	Global Variables		
M4_PD_Out_Chann	Global Variables		
M4_PD_Out_Chann	Global Variables		
M4_PD_Out_Chann	Global Variables		
M4_PD_Out_Chann	Global Variables		



The data type of the I/O variables in the FX20 module defaults to USINT format, and users can select the corresponding variable data type according to their programming habits through the "Edit PDO Map Settings". As shown in the following figure:

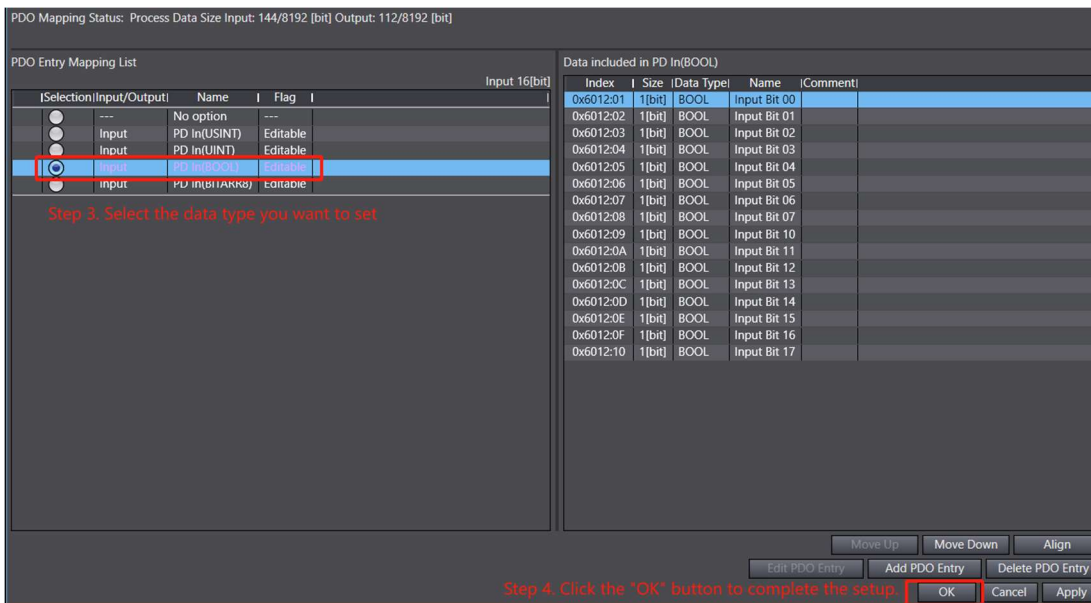
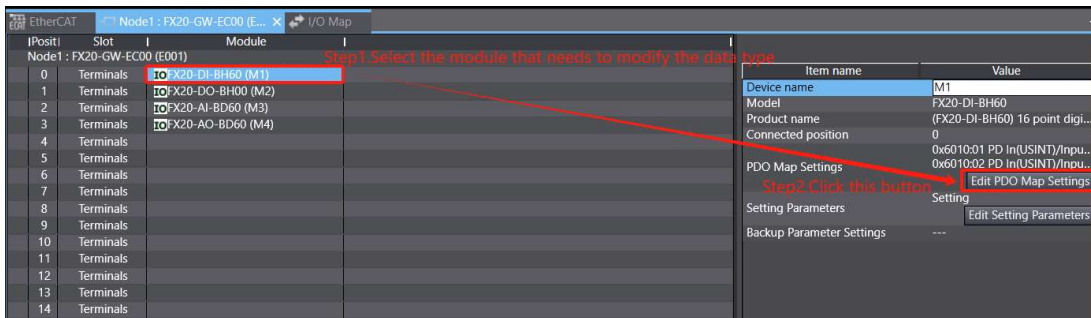

You can use the same steps to modify the data types of other I/O modules.

9.3.1.12. At this point, the configuration of the FX20 module has been completed. It is now necessary to modify the EtherCAT node address of the FX20 adapter to match the program configuration. Switch the software to online mode, double-click to open the "EtherCAT" configuration interface, right-click on the main device, and select "Write Slave Node Address" from the pop-up menu.

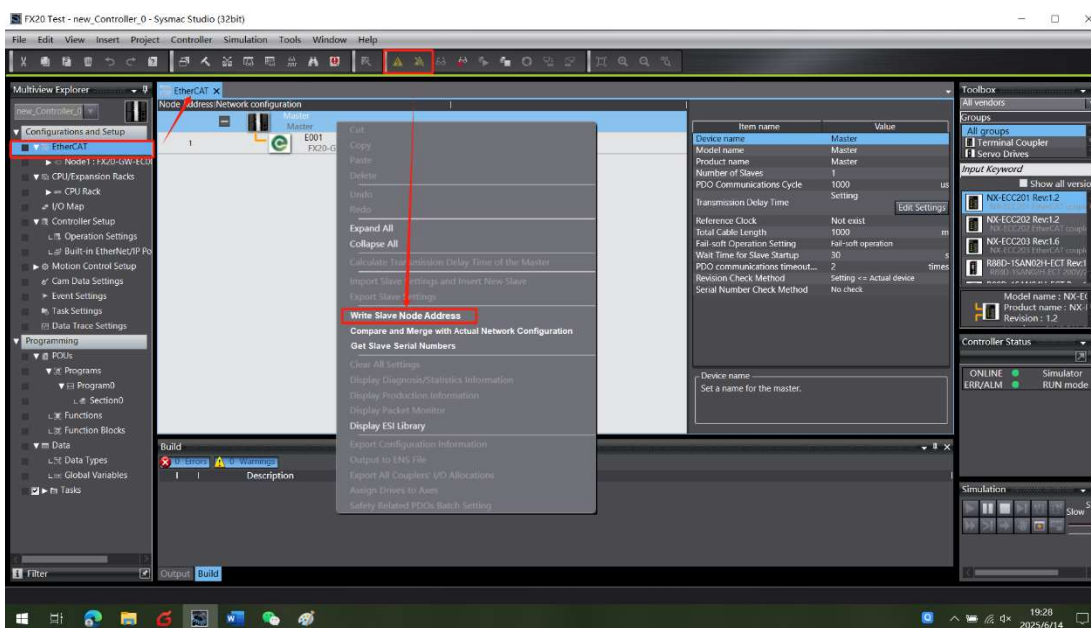



### 9.3.2. Configuration steps in CODESYS

This example takes FX20 series distributed I/O modules as the slave station to connect to Inovance's controller AM401-CPU1608TP/TN with EtherCAT interface. By default, InoProShop has been installed and the required network card information has been set, and all power and bus connections have been completed. Please refer to the InoProShop user manual for the above operation process.

Take the following FX20 modules as a configuration example:

Model	Description	Quantity
FX20-GW-EC00	EtherCAT bus adapter	1
FX20-DI-BH60	16-channel digital input module, PNP/NPN	1
FX20-DO-BH00	16-channel digital output module, PNP	1
FX20-AI-BD60	4-channel analog input module	1
FX20-AO-BD60	4-channel analog output module	1

The software configuration debugging process is as follows:

- 9.3.2.1. Open the InoProShop and click on "New Project" -> "Standard Projects", Select the PLC you used, fill in the project name, then click "OK".

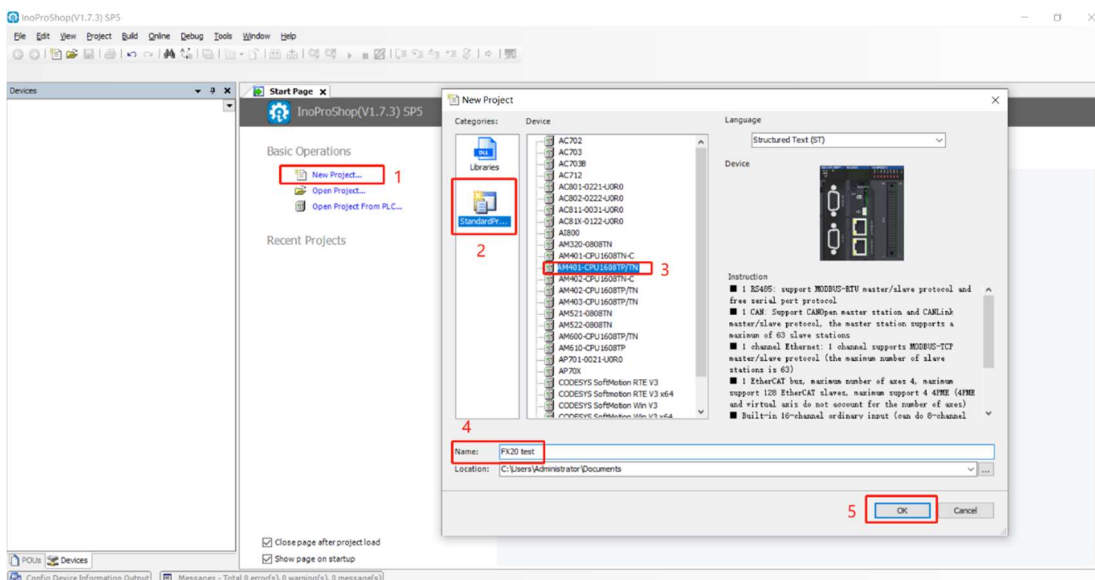

- 9.3.2.2. Click on the "tools" tab in the menu bar, select "Device Repository" from the lower menu.

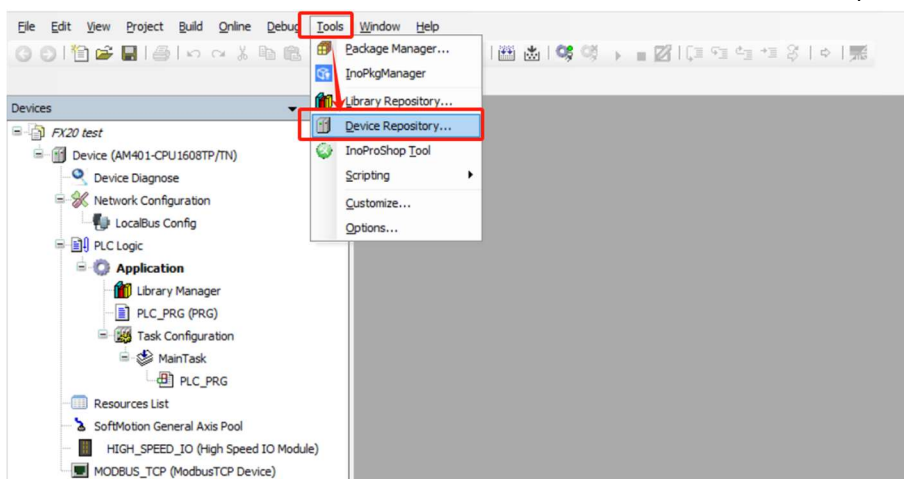

9.3.2.3. Click "Install" on the pop-up interface.

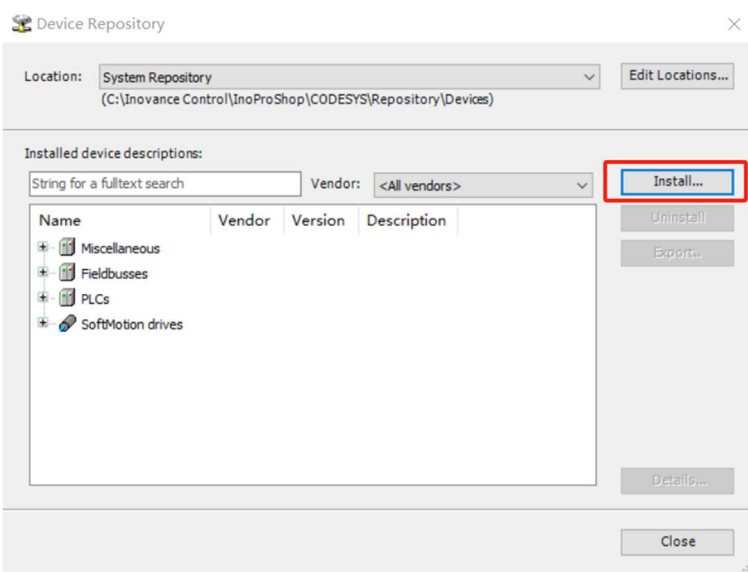

9.3.2.4. Select the FX20 ESI file based on the computer storage path, click "OPEN" button.

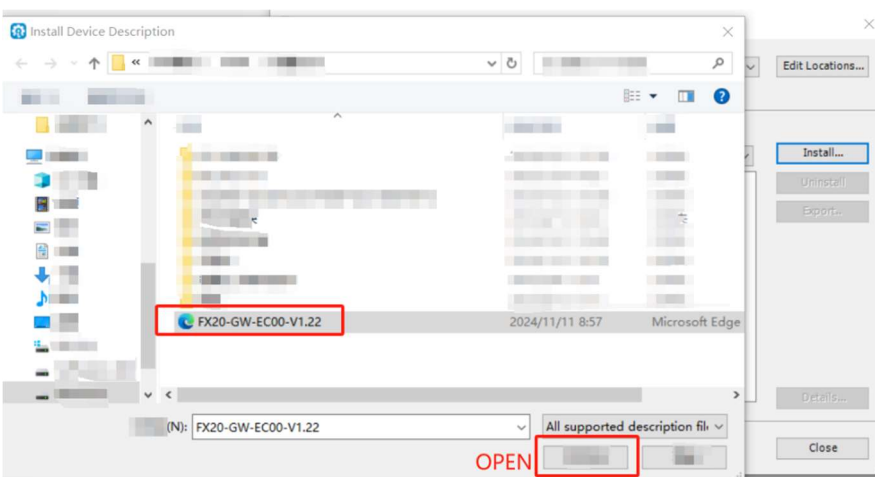

9.3.2.5. Double clicks on the "network configuration", click on the CPU, and select EtherCAT master station in the menu.

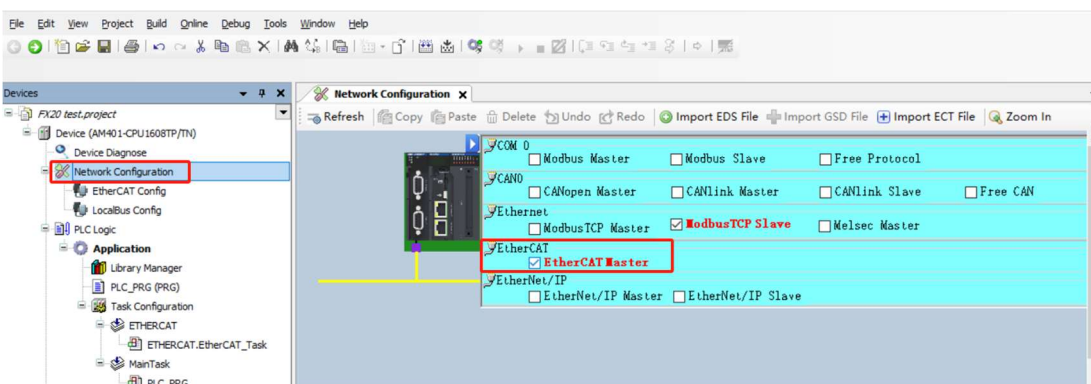

9.3.2.6. In the "Network Devices list" on the right, locate "Flexy20 Master" and double-click the module "FX20-GW-EC00" to add it to the network environment on the left. The system will assign EtherCAT node

addresses based on the connection order (which can also be modified as needed).

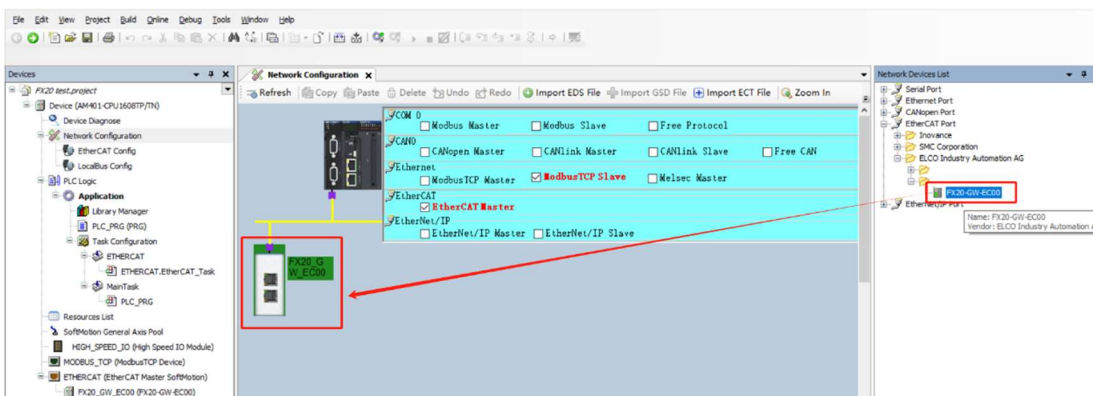

9.3.2.7. In the "Devices" list on the left, right-click on FX20-GW-EC00 and select the "Add Device..." option.

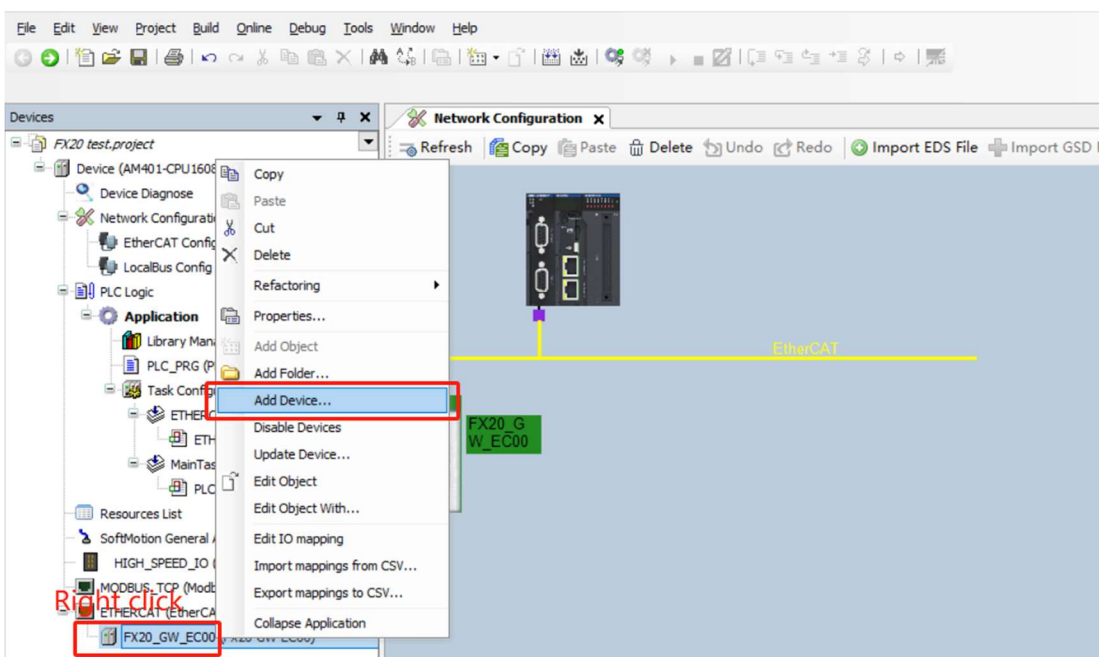

9.3.2.8. In the pop-up "Insert Device" dialog box, double-click or drag the four configured I/O modules in this example, and then click the "Close" button after completion.

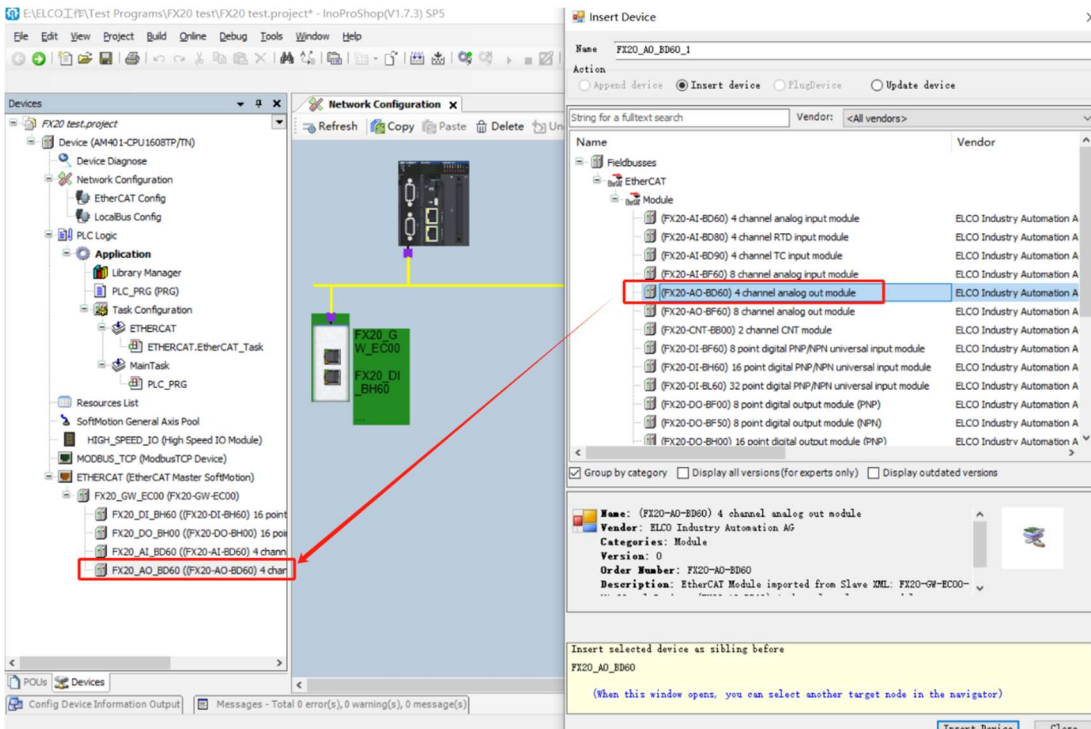

9.3.2.9. The analog module needs to select "Edit Object" from the right-click menu in the device list on the left, and configure the corresponding range, filtering level, channel diagnosis function disable/enabled in the startup parameters (SDO setting).

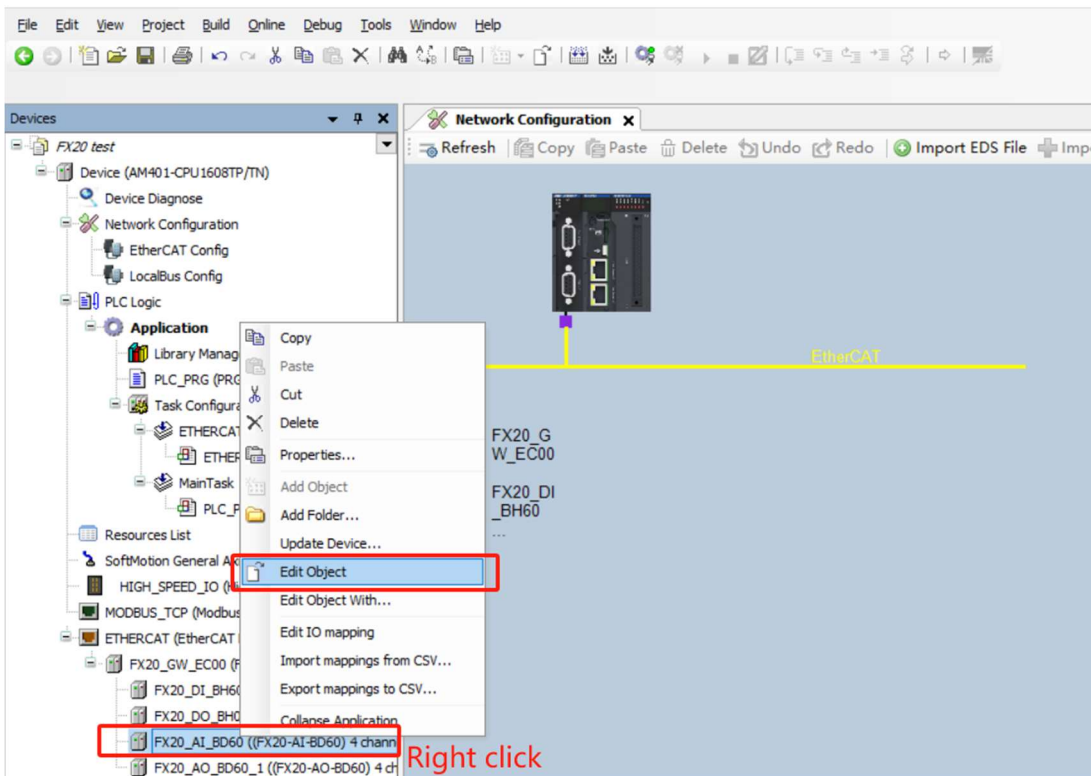

9.3.2.10. Firstly, configure the parameters of the FX20-AI-BD60 module by clicking the "Edit" button and selecting the values that need to be configured for each parameter from the "Value" drop-down menu in the pop-up dialog box, click "OK" to confirm.

By default, the data processing type of the analog module is "little endian", which can also be changed to "big endian" according to the PLC processing method. All channels of the analog signal are deactive. Based on the actual connection signal type, click to select the range, signal type, filtering strength, and whether to add diagnostic data.

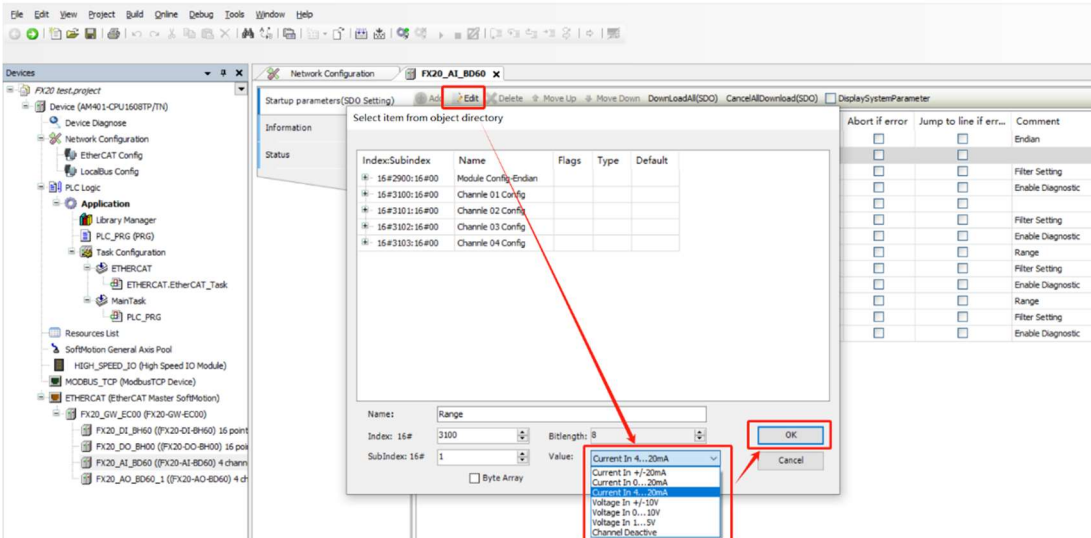

After setting up all channels of the analog input module, the FX20-AO-BD60 can be configured with parameters for each channel using the same method.

9.3.2.11. Double clicks on the FX20 adapter in the "Devices" list, then choose "EtherCAT Mapping". Here, you can see the I/O mapping of FX20, including the reserved bytes of the FX20 adapter, the diagnostic status of the corresponding slot of the I/O module, and the connection status of the corresponding slot of the I/O module.

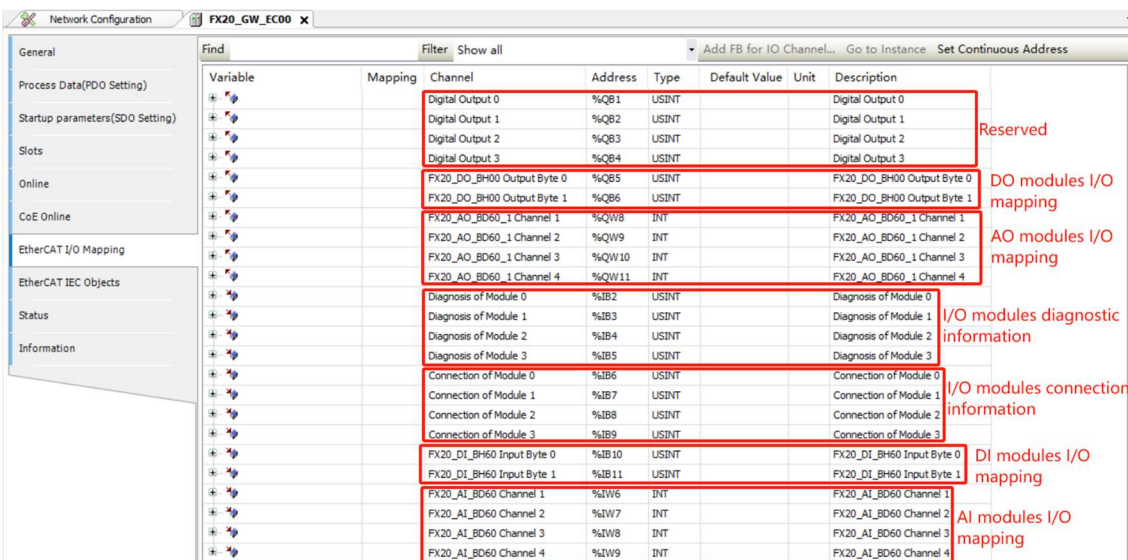

9.3.2.12. In this interface, various variables mapped to this FX20 module can be selected through the "Variables" parameter on the left. Users can also manually create variables as needed.

Variable	Mapping	Channel	Address	Type	Default Value	Unit	Description
		Digital Output 0	%QB1	USINT			Digital Output 0
		Digital Output 1	%QB2	USINT			Digital Output 1
		Digital Output 2	%QB3	USINT			Digital Output 2
		Digital Output 3	%QB4	USINT			Digital Output 3
		FX20_DO_BH00 Output Byte 0	%QB5	USINT			FX20_DO_BH00 Output Byte 0
tag1		Bit0	%QX5.0	BOOL	FALSE		
tag2		Bit1	%QX5.1	BOOL	FALSE		
tag3		Bit2	%QX5.2	BOOL	FALSE		
tag4		Bit3	%QX5.3	BOOL	FALSE		
tag5		Bit4	%QX5.4	BOOL	FALSE		
tag6		Bit5	%QX5.5	BOOL	FALSE		
tag7		Bit6	%QX5.6	BOOL	FALSE		
tag8		Bit7	%QX5.7	BOOL	FALSE		
		FX20_DO_BH00 Output Byte 1	%QB6	USINT			FX20_DO_BH00 Output Byte 1
		FX20_AO_BD60_1 Channel 1	%QW8	INT			FX20_AO_BD60_1 Channel 1
		FX20_AO_BD60_1 Channel 2	%QW9	INT			FX20_AO_BD60_1 Channel 2
		FX20_AO_BD60_1 Channel 3	%QW10	INT			FX20_AO_BD60_1 Channel 3
		FX20_AO_BD60_1 Channel 4	%QW11	INT			FX20_AO_BD60_1 Channel 4
		Diagnosis of Module 0	%IB2	USINT			Diagnosis of Module 0
		Diagnosis of Module 1	%IB3	USINT			Diagnosis of Module 1
		Diagnosis of Module 2	%IB4	USINT			Diagnosis of Module 2
		Diagnosis of Module 3	%IB5	USINT			Diagnosis of Module 3
		Connection of Module 0	%IB6	USINT			Connection of Module 0
		Connection of Module 1	%IB7	USINT			Connection of Module 1

9.3.2.13. At this point, the configuration of the FX20 module has been completed. Connect to the PLC, switch the software to online mode, and click the download button to download the configuration and program to the PLC. At this point, if everything is configured correctly, the RUN indicators of the FX20 coupler is in green, and the MD indicators of the I/O module is in green.



**Other PLC brands based on the CODESYS programming platform have configuration methods similar to InoProShop.**

### 9.4. Representation of analog module values

The PLC processes analog values in binary format. The FX20 analog input module converts analog process signals into digital format, and the analog output module converts digital output values into analog signals.

Digital analog values are applicable to input and output values within the same rated range. Each analog signal occupies PLC address of 1 word, which means each analog signal corresponds to a 16bit value. The symbol of the analog value is always set at the highest bit 15: 0 represents positive and 1 represents negative. For analog modules with a resolution less than 16 bits, analog values are stored in a left aligned manner, and the unused least significant bits are filled with 0. For example, the analog value 18035 can be represented as the following binary value:

Bits	15	14	13	12	11	10	9	8	7	6	5	4	3	2	1	0
16bit	0	1	0	0	0	1	1	0	0	1	1	1	0	0	1	1
14bit	0	1	0	0	0	1	1	0	0	1	1	1	0	0	0	0

Analog signal types can be divided into bipolar and unipolar, with a current bipolar value of ± 20mA (input only) and a voltage bipolar value of ± 10 V, the current unipolarity values are 0-20mA and 4-20mA, and the voltage unipolarity values are 1-5 V and 0-10 V.

The thermal resistor supports 2-wire and 3-wire PT100/1000, and the thermocouple can support multiple TC types (internal compensation) such as J, K, T, N, E, etc.

#### 9.4.1. Analog value input and output range of bipolar current

System value	Current input/output range			
	Decimalism	Hexadecimal	±20 mA	
118.515%	32767	7FFF	≥ 23.7 mA	Overflow, locking max. value
	27649	6C01		Overshoot range
100%	27648	6C00	20 mA	Rated range
75%	20736	5100	15 mA	
0.00362%	1	1	723.4 nA	
0%	0	0	0 mA	
	-1	FFFF	-723.4 nA	
-75%	-20736	AF00	-15 mA	
-100%	-27648	9400	-20 mA	
	-27649	93FF		Overshoot range
-118.519%	-32768	8000	≤ -23.7 mA	Underflow, locking min. value

#### 9.4.2. Analog value input and output range of bipolar voltage

System value	Current input/output range			
	Decimalism	Hexadecimal	± 10V	
	32767	7FFF	> 10.24 V	Overflow, locking max. value
102.4%	28310	6E96	10.24 V	Overshoot range

	27649	6C01		Rated range
100%	27648	6C00	10 V	
75%	20736	5100	7.5 V	
0.00362%	1	1	361.7 $\mu$ V	
0%	0	0	0 V	
	-1	FFFF	-361.7 $\mu$ V	
-75%	-20736	AF00	-7.5 V	
-100%	-27648	9400	-10 V	
	-27649	93FF		Overshoot range
-102.4%	-28310	916A	-10.24 V	Underflow, locking min. value
	-32768	8000	< -10.24V	

**9.4.3. Analog value input and output range of unipolar current**

System value		Current input/output range			
	Decimalism	Hexadecimal	0~20mA	4~20mA	
118.515%	32767	7FFF	$\geq 23.7$ mA	$\geq 22.96$ mA	Overflow, locking max. value
	27649	6C01			Overshoot range
100%	27648	6C00	20 mA	20 mA	Rated range
75%	20736	5100	15 mA	16 mA	
0.00362%	1	1	723.4 nA	4mA+578.7nA	
0%	0	0	0 mA	4 mA	
-0.00362%	-1	FFFF			Overshoot range
-17.59%	-4864	ED00	-3.52 mA	1.185 mA	
	-32768	8000	<-3.52 mA	< 1.185 mA	Underflow, locking min. value

**9.4.4. Analog value input and output range of unipolar voltage**

System value		Current input/output range			
	Decimalism	Hexadecimal	1~5 V	0~10 V	
	32767	7FFF	> 5.7 V	> 10.24 V	Overflow, locking max. value
118.515%	32767	7FFF	5.7 V		Overshoot range
102.4%	28310	6E96		10.24 V	

100%	27648	6C00	5 V	10 V	Rated range
75%	20736	5100	4 V	7.5 V	
0.00362%	1	1	1V+144.7 μV	361.7 μV	
0%	0	0	1 V	0 V	
	-1	FFFF			Overshoot range
-17.59%	-4864	ED00		-1.759 V	
-25%	-6912	E500	0 V		
	-32768	8000	< 0 V	< -1.759 V	Underflow, locking min. value

**9.4.5. Analog value measurement range of PT x00 standard thermal resistance**

System value		Current input range	
Decimalism	Hexadecimal	-200~+850 °C	
32767	7FFF	≥ 850.1 °C	Overflow, locking max. value
8500	2134	850 °C	Rated range
6375	18E7	637.5 °C	
10	A	1 °C	
0	0	0 °C	
-10	FFF6	-1 °C	
-1500	FA24	-150 °C	
-2000	F830	-200 °C	
-32768	8000	≤ -200.1 °C	Underflow, locking min. value

**9.4.6. Representation of simulated values within the measurement range of thermocouples**

For J, K, T, N, and E type thermocouples, determine the rated input and output range based on the temperature range of the graduation table. Divide the decimalism value of the system by 10 to obtain the current temperature, with a resolution of 0.1 °C, and lock max. or min. value when exceeding the limit.

## 10. Fault diagnosis

Name	Status	Meaning	Measures
<b>Bus adapter indicators</b>			
PWR	Green	Normal	None
	Off	Abnormal power supply	<ol style="list-style-type: none"> <li>1. Check if the polarity of the power wiring is correct;</li> <li>2. Check if the power supply voltage is normal;</li> <li>3. Coupler damaged, replace it</li> </ol>
RUN	Green	Normal	None
	Flashing	Pre-OP status	None
	Off	Abnormal communication	<ol style="list-style-type: none"> <li>1. Check if the network cable is connected well;</li> <li>2. Check for configuration errors;</li> <li>3. Coupler failure, replace it.</li> </ol>
ERR	Green	Normal	None
	Red	Error occurred	<ol style="list-style-type: none"> <li>1. Check if there is a short circuit or overload in the IO module;</li> <li>2. Coupler or IO module faulty, replace.</li> </ol>
STA	Green	Normal	None
	Red	Backplane communication error	<ol style="list-style-type: none"> <li>1. Check if the backplane connection between modules is reliable;</li> <li>2. Attempt to power off and restart the FX20 system again.</li> </ol>
<b>Digital I/O indicators</b>			
PW	Green	Normal	None
	Off	24 V power supply abnormal	<ol style="list-style-type: none"> <li>1. Check if the I/O module 24 V wiring is correct;</li> <li>2. Check if the value. I/O module 24 V power supply voltage is normal;</li> <li>3. IO module damaged, replace.</li> </ol>
MD	Green	Normal	None
	Green blinking	Connected but not configured	Check if the modules are configured correctly.
	Red and green flashing alternately	Backplane communication abnormal	<ol style="list-style-type: none"> <li>1. Check if the connections between modules are reliable;</li> <li>2. Restart FX20 system power supply;</li> <li>3. I/O module malfunction, replace it.</li> </ol>
	Red	Module error	<ol style="list-style-type: none"> <li>1. Check if the I/O module is configured correctly;</li> <li>2. Check if there is a short circuit or overload in the I/O module;</li> <li>3. I/O module damaged, replace.</li> </ol>
00-07 10-17 20-27 30-37	Green	Signal '1'	None
	Off	Signal '0'	None
<b>Analog I/O indicators</b>			

PW	Green	Normal	
	Off	24 V power supply abnormal	<ol style="list-style-type: none"> <li>1. Check if the IO module 24 V wiring is correct;</li> <li>2. Check if the IO module 24 V power supply voltage is normal;</li> <li>3. I/O module damaged, replace.</li> </ol>
MD	Green	Normal	
	Green blinking	Connected but not configured	Check if the modules are configured correctly.
	Red and green flashing alternately	Backplane communication abnormal	<ol style="list-style-type: none"> <li>1. Check if the connections between modules are reliable;</li> <li>2. Restart FX20 system power supply;</li> <li>3. I/O module malfunction, replace it.</li> </ol>
	Red	Module error	<ol style="list-style-type: none"> <li>1. Check if the I/O module is configured correctly;</li> <li>2. Check if there is a short circuit or overload in the IO module;</li> <li>3. The analog channel value exceeds the range;</li> <li>4. I/O module damaged, replace.</li> </ol>
C1-C4	Off	Normal	None
	Red	Channel out of range	Check the range of analog input and output signals.
<b>Auxiliary power supply module indicators</b>			
PW	Green	Normal	None
	Red	24 V over voltage or under voltage	Check if the input 24V power supply voltage is normal.
Us	Green	Normal	None
	Off	No backplane 5V power supply	<ol style="list-style-type: none"> <li>1. Check if the backplane connection between modules is reliable;</li> <li>2. Power module damaged, replaced.</li> </ol>