

SA / SC Series High performance bus servo system





Product C

- Ⓢ Product Overview 4
- Ⓢ Model Number Description 7
- Ⓢ SC Series Standard High-performance Bus-type Servo Drive 8
 - Technical Specifications 8
 - Specification Data 9
 - Wiring diagram 10
 - Dimension drawing 15
- Ⓢ SA Series Economical High-performance Bus-type Servo Drive 17
 - Technical Specifications 17
 - Specification Data 18
 - Dimension drawing 18
 - Wiring diagram 19
- Ⓢ Drive accessories 21
- Ⓢ Braking resistor 22
 - Braking resistor selection table 22
 - Braking resistor naming convention 23
 - Dimension drawing 23

- Power range: 0.2~3 kW
- EtherCAT high-speed real-time Ethernet
- Integrated SS (Safe Stop) and STO (Safe Torque Off) safety functions
- High dynamic response: Current loop cycle 1.6μs, speed loop cycle 62.5 μs, position loop cycle 125 μs
- High precision: Supports up to 25-bit encoder
- High usability: Features one-key auto-tuning, electronic nameplate, vibration suppression, etc.

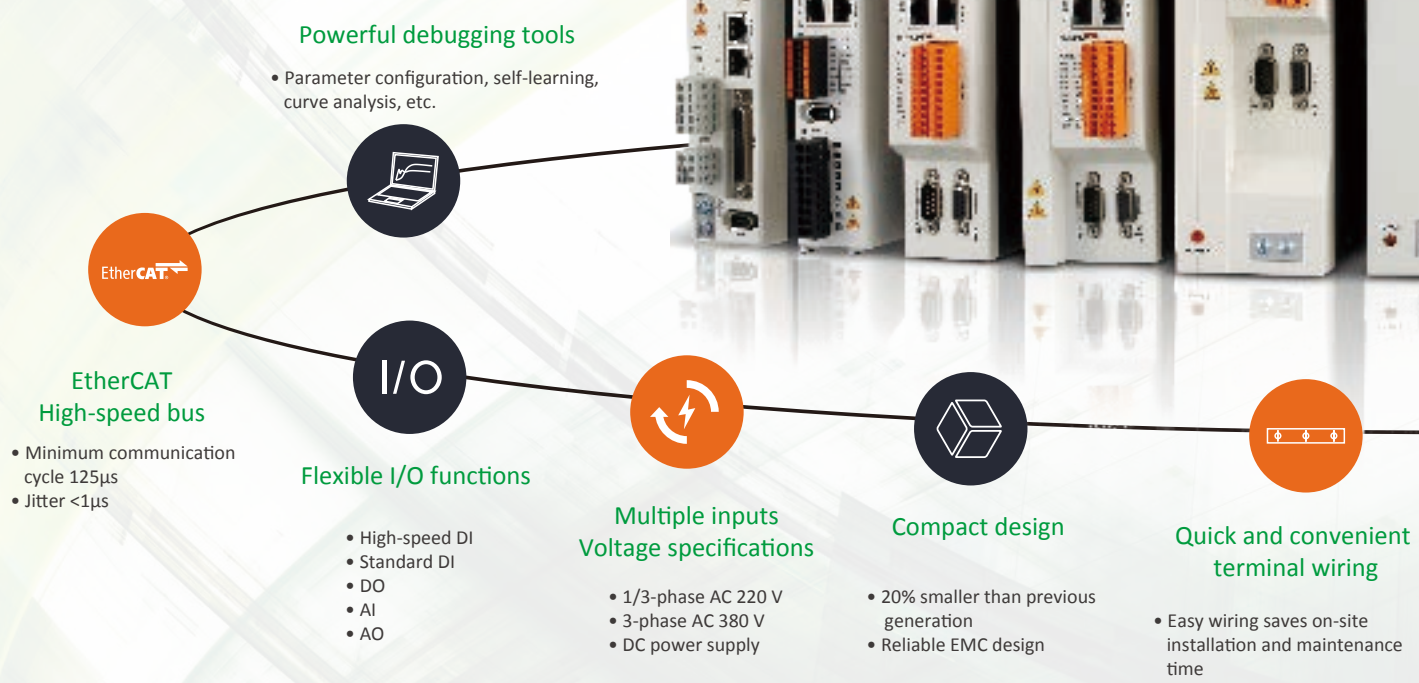

Industry Applications



Automotive Manipulators & Industrial Robots Lithium Batteries Consumer Electronics



High-level safety protection design

- STO
- SS



Quick and convenient panel operation

- Integrated stiffness table for simpler and more convenient debugging
- Built-in jogging, self-learning and other functions
- Information diagnostics



Wide range of encoder types

- Tamagawa protocol encoder, EnDat, Panasonic, Resolver, ABZ

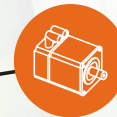

High-performance servo motor

- Wide torque range
- High dynamic response PMSM (Permanent Magnet Synchronous Motor)



Excellent control performance

- Position loop cycle: 125 μ s
- Speed loop frequency response \geq 2.5 kHz



Printing



New Energy

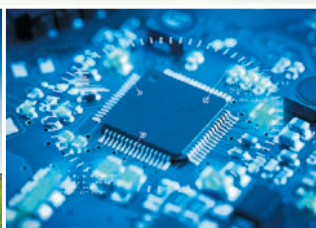

Semiconductor & Electronics



Amusement



Food Packaging

SA & SC Series High-performance Bus-type Servo Drives

SA/SC high-performance servo drives perfectly integrate with M1 series servo motors, suitable for various driving applications, enabling seamless switching between position control, speed control and torque control. Through optimized design, SA/SC servo system delivers excellent performance, rich functionality and reliable stability, providing convenient and flexible user experience.

• Application

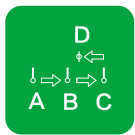

Point-to-point positioning



Synchronization

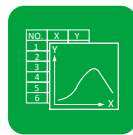

Motion planning

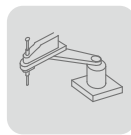

SCARA robot



SCARA robot



Homing

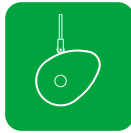

Cam

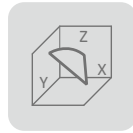

Spatial interpolation

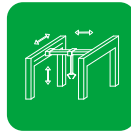

XYZ Cartesian robot

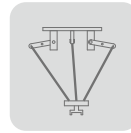

Delta robot

• Typical application

High-performance servo drives



M1 Series Three-phase AC Permanent Magnet Synchronous Servo Motor

Ordering Informations

S A 2 - E 4R2 M S - □

A2: Series

Model Code	Representative Type
A	Economy Servo Controller
C	Standard Servo Controller

2: Control Precision

Model Code	Representative Type
1	17-bit Precision
2	23-bit Precision

E: Control interface mode

Model Code	Description
E	EtherCAT Bus Control Type
P	Pulse Control Type

4R2: Rated Output Current

Model Code	Description
1R8	1.8 Arms
2R8	2.8 Arms
3R5	3.5 Arms
4R2	4.2 Arms
060	6.0 Arms
100	10.0 Arms
120	12.0 Arms
140	14.0 Arms
250	25.0 Arms
340	34.0 Arms

Customized Parameters

Model Code	Description
	Standard Type
S	STO Type (Safe Torque Off)
SA	High-precision Analog Input + STO + Frequency Division Output Type (SC only)

S Voltage Rating & Input Method

Model Code	Description
S	Single-phase AC 220 V
T	Three-phase AC 380 V (N2 only)

M: Capacity Rating

Model Code	Description
M	Standard Capacity Type
H ²⁾	Enhanced Capacity Type

Note:

1) Naming conventions are for model identification only and cannot be used for ordering. Please consult before placing orders.

2) With the same current capacity, increased capacitance provides higher output power, suitable for applications with frequent current surges.

SC Series Standard High-performance Bus-type Servo Drive



General Specifications

Operating Environment	
Storage Temperature	-20 ... +65 °C
Transport Temperature	-20 ... +70 °C
Operating Temperature	0 ... +45 °C
Relative Humidity	≤ 90%RH, non-condensing
Vibration Resistance	4.9 m/s ²
Shock Resistance	19.6 m/s ²
Altitude	≤ 1000 m; 1000 m, derate 1.1% per 100 m increase Maximum altitude 2000 m
Working Environment	Free from corrosive / flammable gases, oil mist, conductive dust, or dirt
Protection Class	IP20
Flame Retardant Class	V0

Voltage	
Voltage Range	1/3-phase AC 200 V~AC 240 V; 3-phase AC 345 V~AC 440 V
Frequency	50/60 Hz ±5%
PWM Frequency/Control Method	10 kHz / Sinusoidal Current Drive

Safety	
STO (Safe Torque Off) Standard *	IEC 61800-5-2, SIL3 Ple
SS (Safe Stop) Standard	

IO	
DI	5*DI (2 high-speed DI < 10 μs, 3 standard DI < 50 μs)
DO	4*DO (Max. DC 30 V / 50 mA per channel)
AI	2*AI, 12-bit (16-bit Note) resolution, -10 ... +10 V
AO	1*AO, 12-bit resolution, -10 ... +10 V
Internal DC 24 V	5 W
Output Power	

Communication	
EtherCAT	CoE (PDO, SDO), DC-Distributed Clock
Communication Distance	Max. 100 m (ideal environment, quality cable)

Motor Connection	
Output Voltage	AC 0 ... 220 V / AC 0 ... 400 V
Output Frequency	0 ... 600 Hz
Supported Motor Types	3-phase AC Synchronous Servo Motor
Built-in Encoder	17-bit / 23-bit Single / Multi-turn Absolute Encoder
Secondary Encoder	ABZ, Reduced-wiring ABZ
Maximum Cable Length	60 m

Note:

Custom version AI resolution is 16 bit

* Only available for custom versions, contact for details

SC Series Standard High-performance Bus-type Servo Drive

AC 220 V SC Drive Specification Data

Model	1R8MS	2R8MS	4R2MS	060MS	100MS	120MS	120HS	140MS
Main Power Supply	AC 200 V ... AC 240 V; 50/60 Hz							
Control Power Supply	AC 200 V ... AC 240 V; 50/60 Hz; 30 W							
Power Rating	200 W	400 W	750 W	1.0 kW	1.5 kW	1.5 kW	2.0 kW	3.0 kW
Single-phase Input Current	2.5 Arms	4.1 Arms	6.1 Arms	8.2 Arms	10.5 Arms	11.8 Arms	14.0 Arms	20.0 Arms
Three-phase Input Current	1.2 Arms	1.9 Arms	2.8 Arms	4.0 Arms	6.7 Arms	7.0 Arms	8.2 Arms	9.3 Arms
Rated Output Current	1.8 Arms	2.8 Arms	4.2 Arms	6.0 Arms	10.0 Arms	12.0 Arms	12.0 Arms	14.0 Arms
Maximum Output Current	5.4 Arms	8.4 Arms	12.6 Arms	18.0 Arms	30.0 Arms	35.0 Arms	35.0 Arms	35.0 Arms
Overload Factor	300%	300%	300%	300%	300%	280%	280%	250%
Built-in Braking Resistor	×	×	40 W, 80 Ω	60 W, 40 Ω	60 W, 40 Ω	60 W, 40 Ω	100 W, 20 Ω	100 W, 20 Ω
Minimum External Braking Resistance	40 Ω	40 Ω	40 Ω	25 Ω	25 Ω	25 Ω	20 Ω	20 Ω
Dimensions W × H × D (mm)	45 × 180 × 165	45 × 180 × 165	45 × 180 × 165	60 × 180 × 165	60 × 180 × 165	60 × 180 × 165	70 × 192 × 181	70 × 192 × 181
Dimensional Specifications	A1	A1	A1	A2	A2	A2	A3	A3

AC380V SC Technical Specifications

Model	5R4MT	6R8MT	8R3MT	100MT	120MT	140MT	210MT	250MT	340MT
Main Power Supply	Three-phase AC 345 V ... AC 440 V; 50/60 Hz								
Control Power Supply	DC 24 V, -10% ... +10%; 36 W								
Minimum current consumption of the driver	1 Arms	1 Arms	1 Arms	1 Arms	1 Arms	1 Arms	1.3 Arms	1.3 Arms	1.3 Arms
Power	2 kW	3 kW	4 kW	5 kW	6 kW	7 kW	9 kW	10 kW	15 kW
Three-phase input current *	7.3 Arms	9.2 Arms	10.7 Arms	11.7 Arms	14 Arms	17 Arms	24 Arms	28 Arms	38 Arms
Rated output current	5.4 Arms	6.8 Arms	8.3 Arms	10 Arms	12 Arms	14 Arms	21 Arms	25 Arms	34 Arms
Maximum output current	16.2 Arms	20.4 Arms	24 Arms	30 Arms	35 Arms	35 Arms	62.5 Arms	62.5 Arms	66 Arms
Overload factor	300%	300%	290%	300%	290%	250%	290%	250%	194%
Built-in braking resistor	×	×	×	×	×	×	×	×	×
Minimum resistance value of the external braking resistor	50 Ω	50 Ω	50 Ω	50 Ω	50 Ω	50 Ω	20 Ω	20 Ω	20 Ω
Size information W*H*D(mm)	70 × 265 × 218			80 × 265 × 218			115 × 375 × 218		
Size specification	B1			B2			B3		
Recommended circuit breaker current	$\text{Three-phase input current} \times \frac{\text{Matched Motor Power}}{\text{Matched Drive Power}} \quad (\text{Note 2})$								

Note:

- For external braking resistor selection, please refer to the Braking Resistor Selection Table in the Drive Accessories section.
- Example: For 250 MS drive at 10kW full load (28 A three-phase input), when matching 9 kW servo motor, recommended breaker current is $28 \times 9 / 10 = 25.2$ A
- Data marked with "*" are measured at three-phase 380 V.

SC Series Standard High-performance Bus-type Servo Drive

SC Drive Wiring Diagram

AC 220 V Class A1 / A2 Standard Type

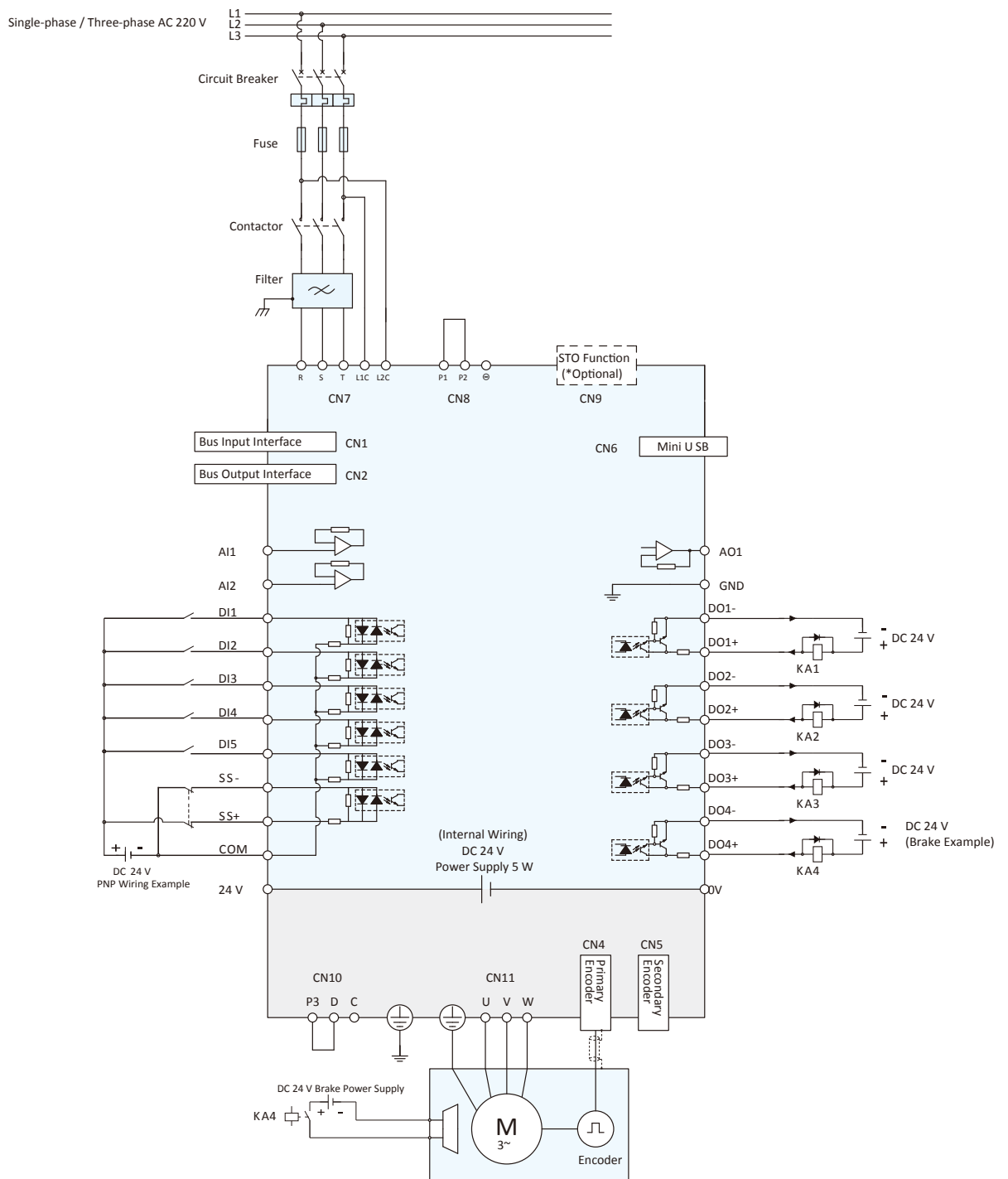

Note:

1. This is a wiring example. Actual wiring may vary depending on drive specifications. See user manual or consult for details.
- 2) For single-phase, connect any two phases from R, S, T.
- 3) DI1 and DI2 are high-speed DI.
- 4) For custom types, refer to user manual or consult for details.

SC Series Standard High-performance Bus-type Servo Drive

SC Drive Wiring Diagram

AC 220 V Class A3 Standard Type

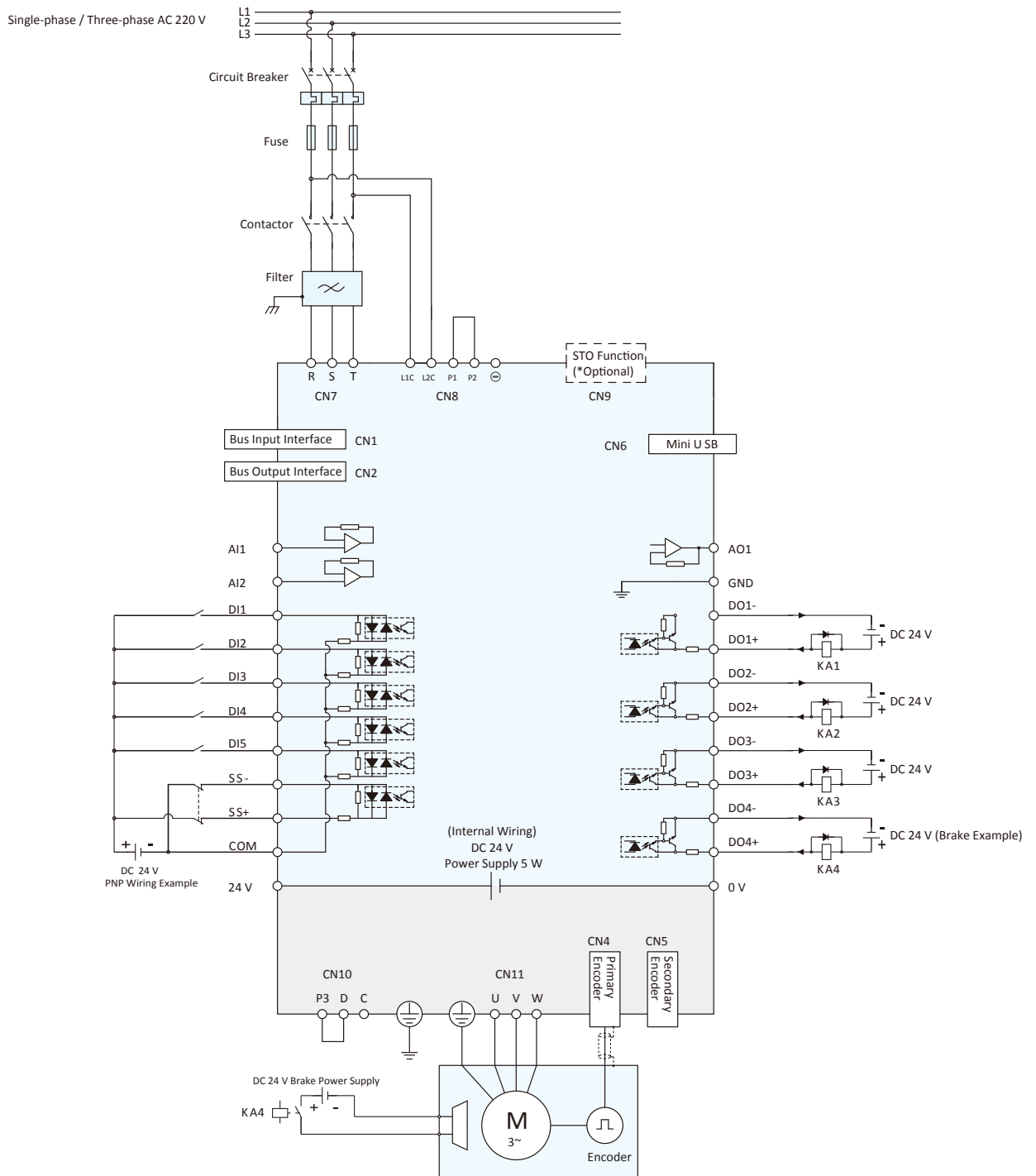

Notes:

- 1) This wiring diagram is for reference only. Actual wiring may vary depending on drive specifications. Please refer to the user manual or consult technical support.
- 2) For single-phase connection, use any two phases from R, S, T.
- 3) DI1 and DI2 are high-speed digital inputs.
- 4) For custom models, please refer to the user manual or contact us for details.

SC Series Standard High-performance Bus-type Servo Drive

SC Drive Wiring Diagram

AC 380 V Class B1 / B2 Standard Specification

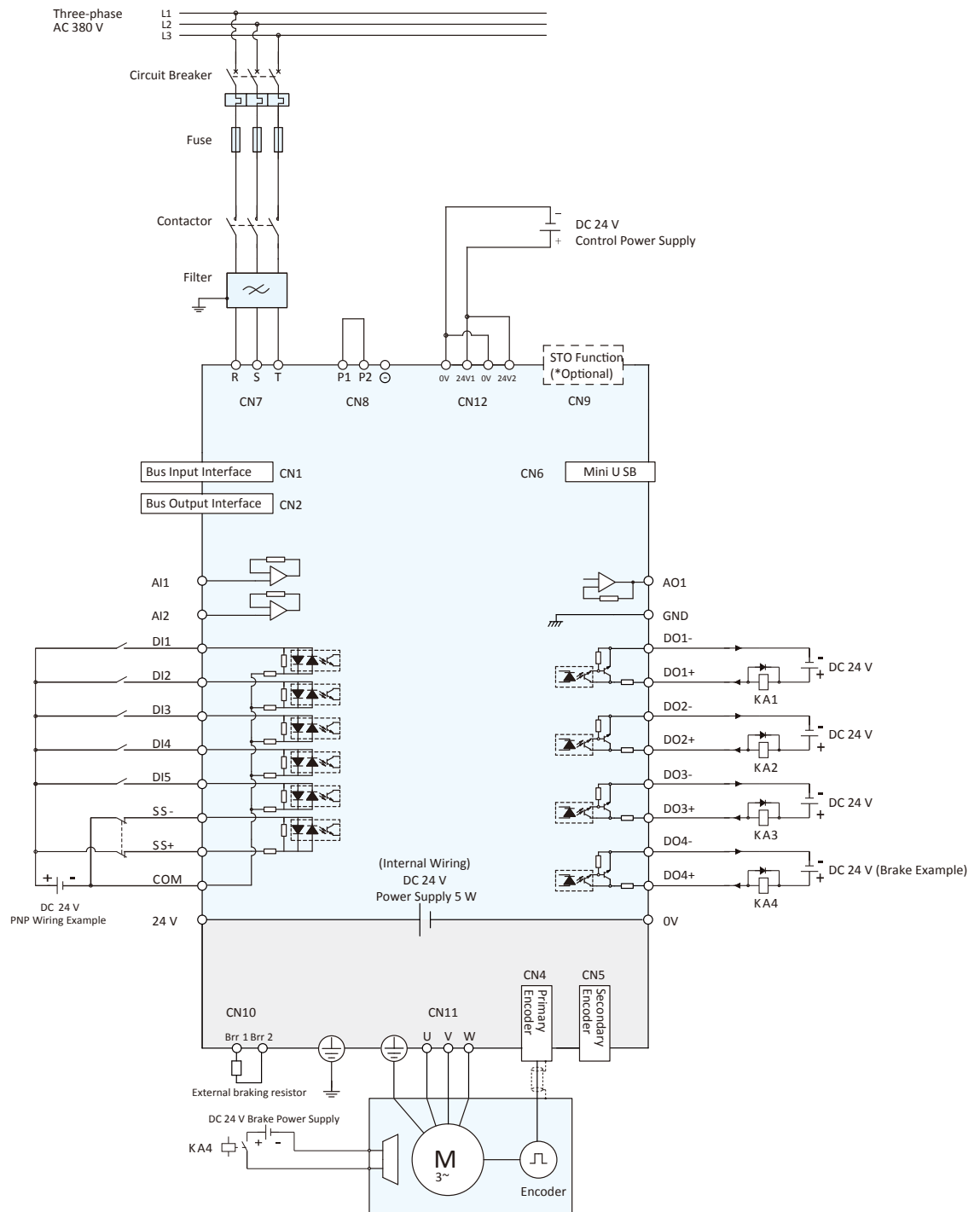

Note:

- 1) This is a wiring example. Actual connections may vary by drive specification. Refer to the user manual or consult technical support.
- 2) his wiring example is for B1 / B2 specification drives ONLY. Never use
- 3) DI1 and DI2 are high-speed digital inputs (DIs).
- 4) For custom models, refer to the user manual or contact support.

SC Series Standard High-performance Bus-type Servo Drive

SC Drive Wiring Diagram

AC 380 V Class B3 Standard Specification

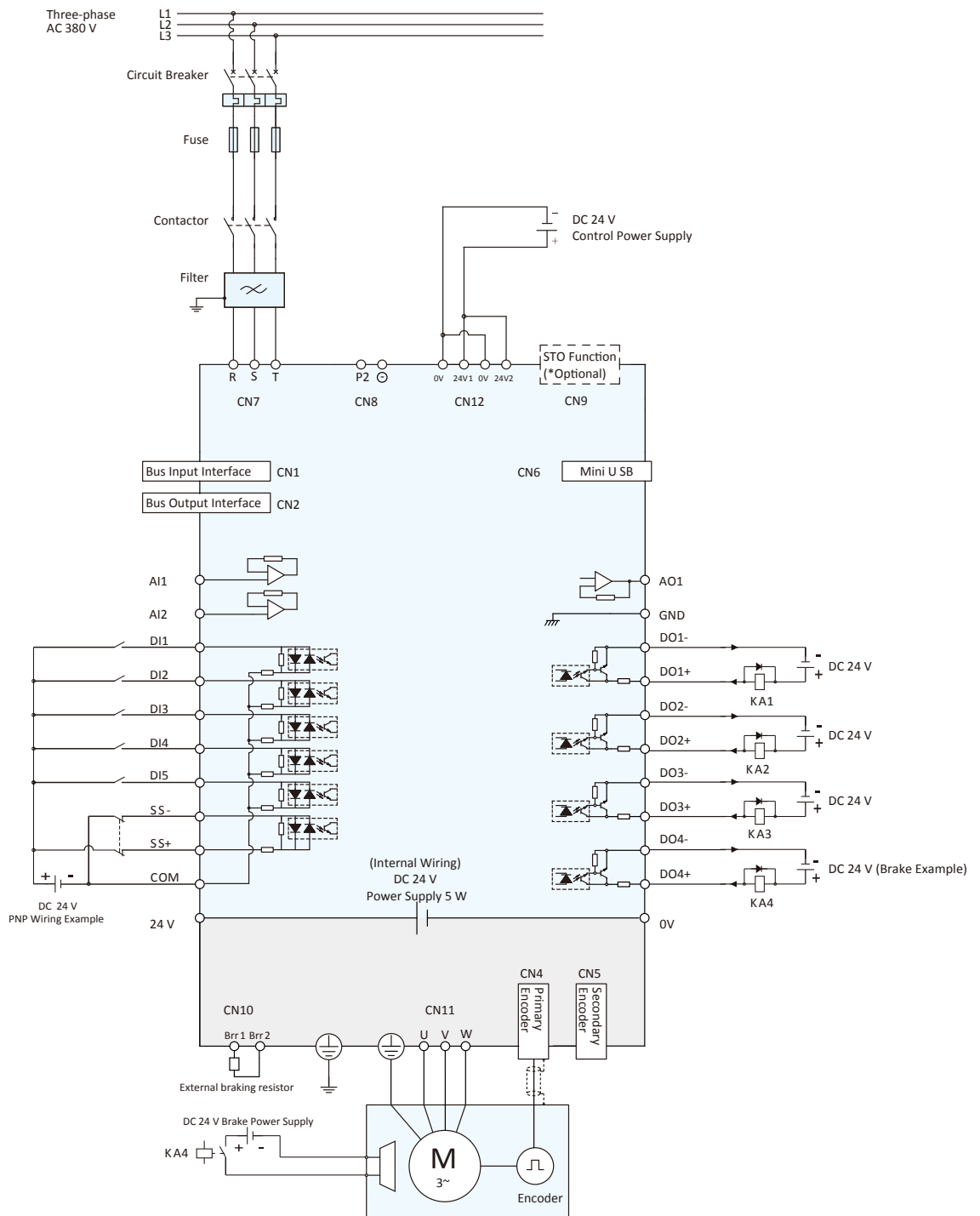

Note:

- 1) Wiring example shown. Actual wiring may vary depending on drive specifications. Refer to user manual or contact technical support.
- 2) DI1 and DI2 are high-speed digital inputs (DIs).
- 3) For custom models, refer to user manual or consult technical support.

SC Series Standard High-performance Bus-type Servo Drive

Drive Wiring Diagram

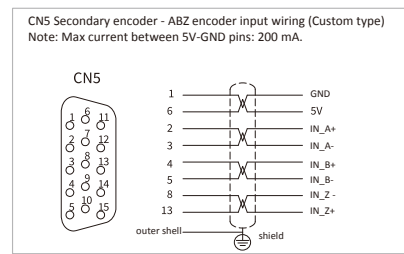
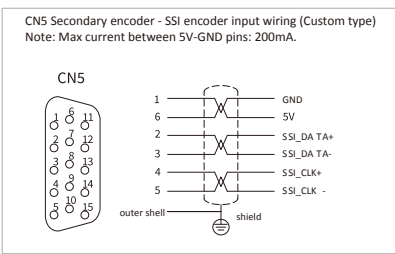
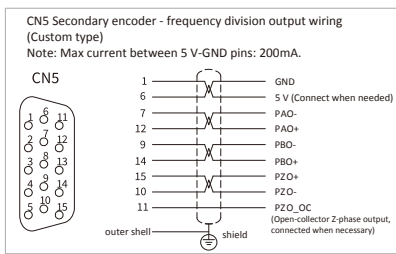
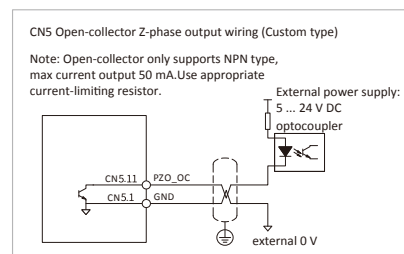
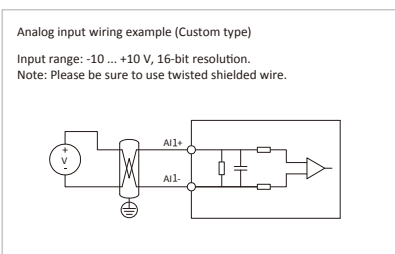
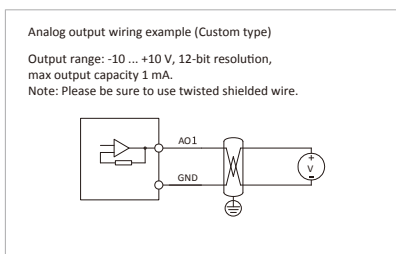
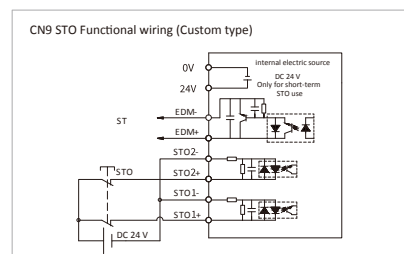
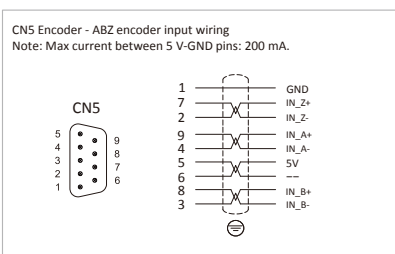
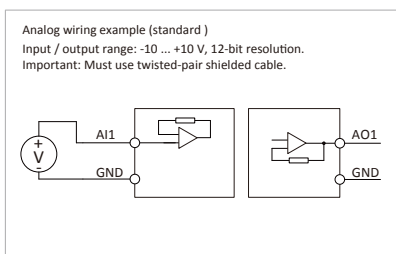
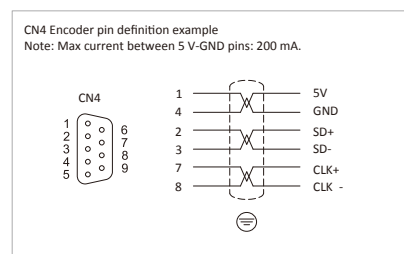
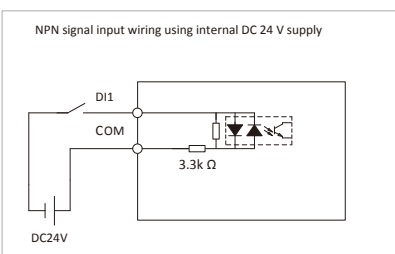
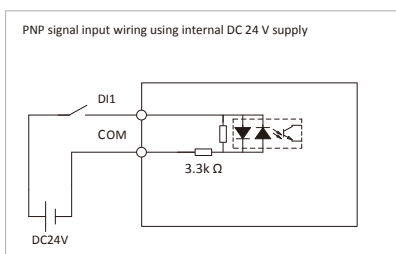
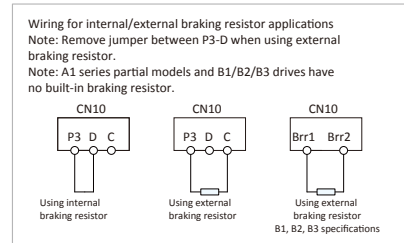
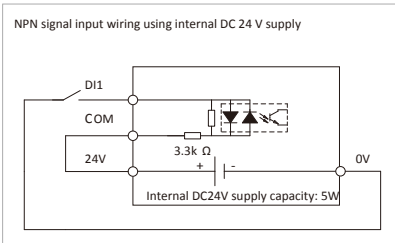
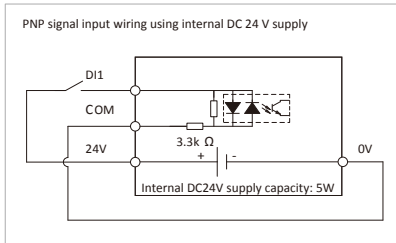
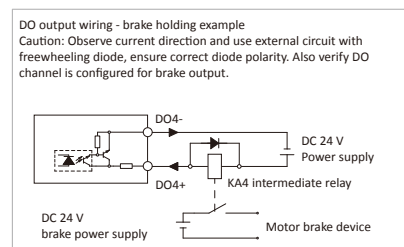
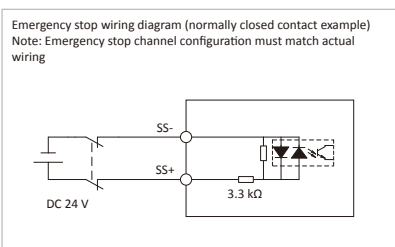
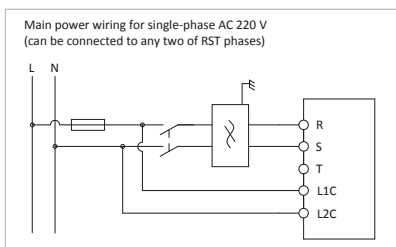

SC Series Standard High-performance Bus-type Servo Drive

Drive Dimensional Drawing

AC 220 V Class SC Drive

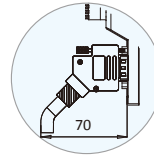
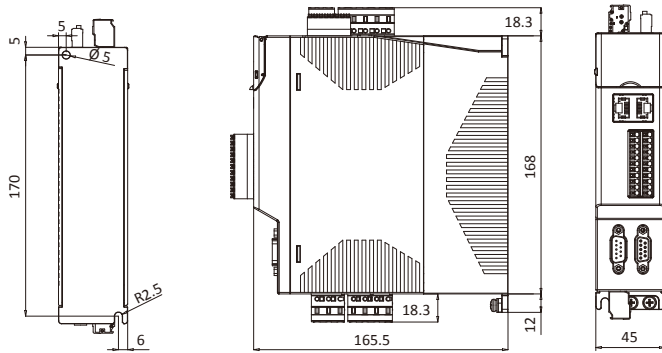

Note: Minimum cable bend radius is 70 mm

No.	Drive Model	Dimensions W × H × D (mm)
1	SC2-E1R8MS	A1 45 × 180 × 165
2	SC2-E2R8MS	
3	SC2-E4R2MS	

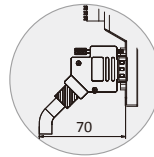
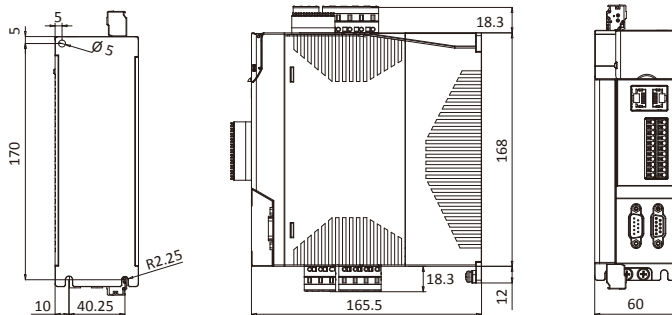

Note: Minimum cable bend radius is 70 mm

No.	Drive Model	Dimensions W × H × D (mm)
1	SC2-E060HS	A2 60 × 180 × 165
2	SC2-E100MS	
3	SC2-E120MS	

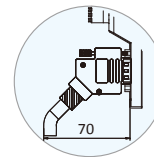
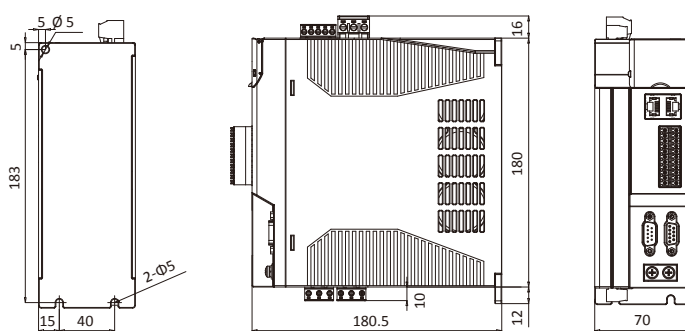

Note: Minimum cable bend radius is 70 mm

No.	Drive Model	Dimensions W × H × D (mm)
1	SC2-E120HS	A3 70 × 192 × 181
2	SC2-E140MS	

SC Series Standard High-performance Bus-type Servo Drive

Drive Dimensional Drawing

AC 380 V Class SC Drive

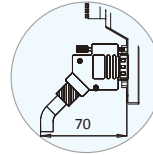
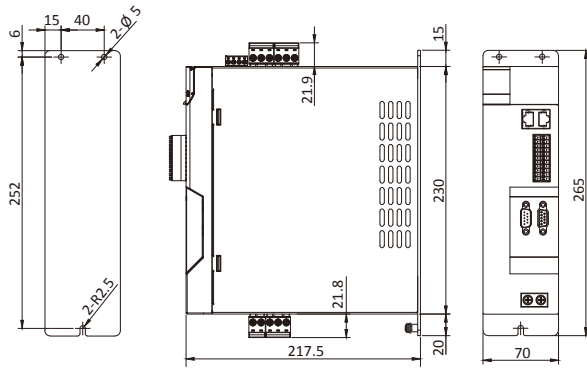

Note: Minimum cable bend radius is 70 mm

No.	Drive Model	Dimensions W × H × D (mm)
1	SC2-E5R4MT	B1 70 × 265 × 218
2	SC2-E6R8MT	
3	SC2-E8R3MT	

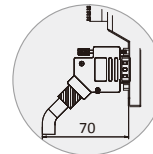
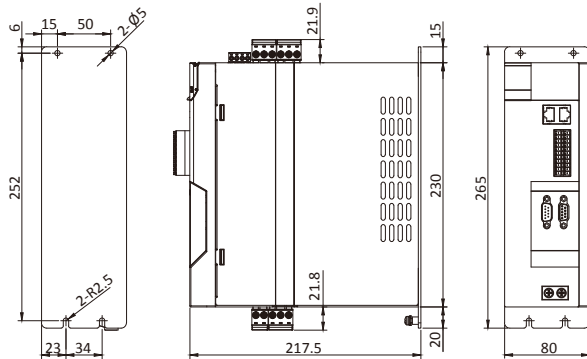

Note: Minimum cable bend radius is 70 mm

No.	Drive Model	Dimensions W × H × D (mm)
1	SC2-E100MH	B2 80 × 265 × 218
2	SC2-E120MH	
3	SC2-E140MH	

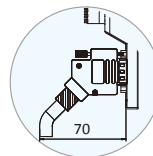
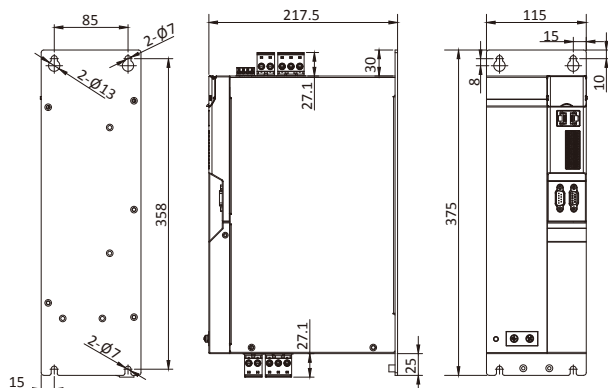

Note: Minimum cable bend radius is 70 mm

No.	Drive Model	Dimensions W × H × D (mm)
1	SC2-E210MH	B3 115 × 375 × 218
2	SC2-E250MH	
3	SC2-E340MH	

SA Series Economical High-performance Bus-type Servo Drives



Technical Specifications

Operating Environment	
Storage Temperature	-20 ... +65 °C
Transport Temperature	-20 ... +70 °C
Operating Temperature	0 ... +45 °C
Relative Humidity	≤ 90% RH (non-condensing)
Vibration Resistance	4.9 m/s ²
Shock Resistance	19.6 m/s ²
Operating Altitude	< 1000 m Derate 1.1% per 100m above 1000 m, max. operating altitude 2000 m.
Working Conditions	Non-corrosive, non-flammable, oil-free, non-conductive dust-free environment
Protection Rating	IP20
Flame Resistance Rating	V0

Voltage	
Range	AC 200 V ... AC 240 V
Frequency	50/60 Hz±5%
PWM Frequency / Control Method	8 K / Sinusoidal Current Drive

Safety	
Safe Torque Off (STO) Standard	IEC 61800-5-2, SIL3 Ple
Safe Stop Standard	

IO	
DI	5*DI, Refresh Cycle: 200 µs
DO	4*DO, Max. withstand voltage DC 30 V per channel, max. continuous current DC 50 mA

Communication	
EtherCAT	CoE (PDO, SDO), DC-Distributed Clock, sync cycle jitter < 1 µs
Communication Distance	Max. 100 m (under ideal conditions with high-quality cables)

Motor Connection	
Output Voltage	AC 0 ... 220 V
Output Frequency	0 ... 600 Hz
Supported Motor Types	3-phase AC Synchronous Servo Motor
Built-in Encoder	17-bit / 23-bit Communication-type Encoder
Maximum Cable Length	60 m

* Only available for custom models, please inquire for details

SA Series Economical High-performance Bus-type Servo Drives

AC220V SA Drive Specification Data

Model	1R8MS	2R8MS	3R5MS	4R2MS
Input Power	AC 200 V ~ AC 240 V			
Frequency	50/60 Hz			
Power	200 W	400 W	600 W	750 W
Single-phase Input Current	2.5 A rms	4.1 A rms	5.2 A rms	6.1 A rms
Rated Output Current	1.8 A rms	2.8 A rms	3.5 A rms	4.2 A rms
Maximum Output Current	7.2 A rms	9.8 A rms	10.5 A rms	12.6 A rms
Overload Factor	400%	350%	300%	300%
Built-in Braking Resistor	×	×	40 W, 80 Ω	40 W, 80 Ω
Minimum External Braking Resistance	50 Ω	50 Ω	50 Ω	50 Ω
Dimensional Information W x H x D (mm)	40 × 175 × 150	40 × 175 × 150	50 × 175 × 150	50 × 175 × 150
Dimensional Specifications	C1	C1	C2	C2

Drive Dimensional Drawing

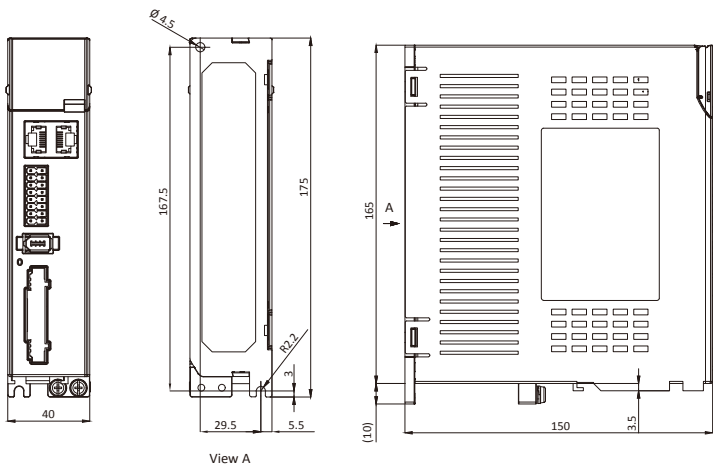

No.	Drive Model	Dimensions W × H × D (mm)
1	SA1-E1R8MS	C1
2	SA1-E2R8MS	40 × 175 × 150

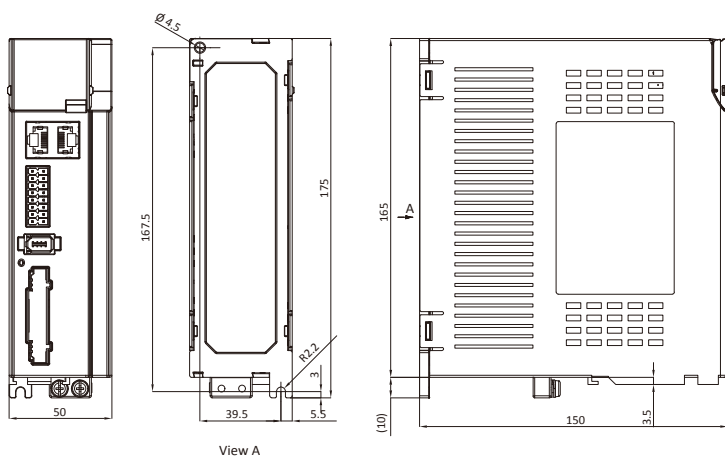

No.	Drive Model	Dimensions W × H × D (mm)
1	SA1-E3R5MS	C2
2	SA1-E4R2MS	50 × 175 × 150

SA Series Economical High-performance Bus-type Servo Drives

SA Wiring Diagram

AC 220 V

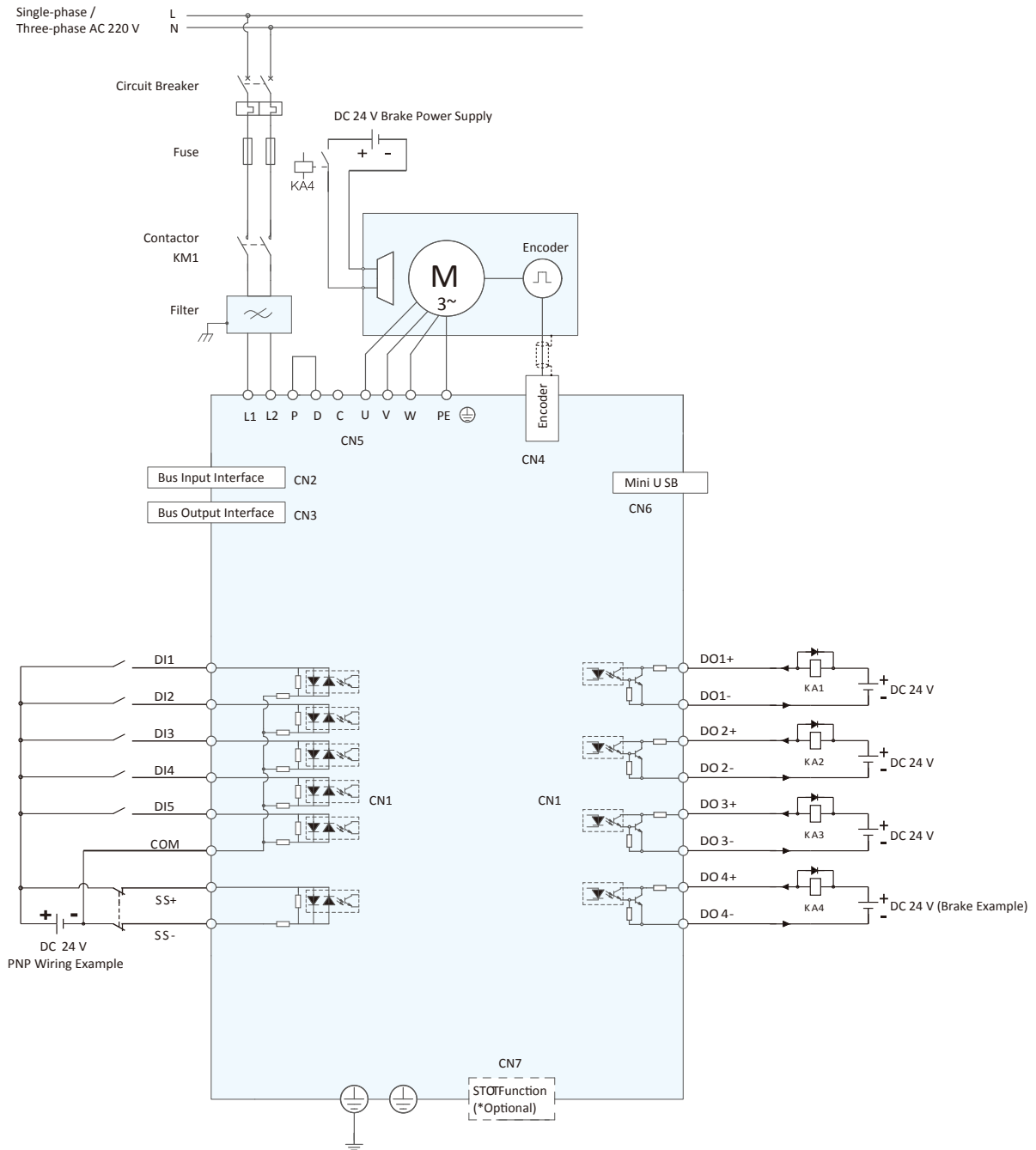

Note: This is the wiring diagram of the standard SA drive. Please carefully check whether the actual drive matches it before wiring.

SA Series Economical High-performance Bus-type Servo Drives

Wiring Diagram

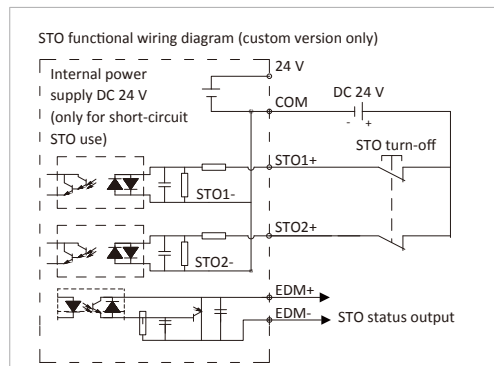
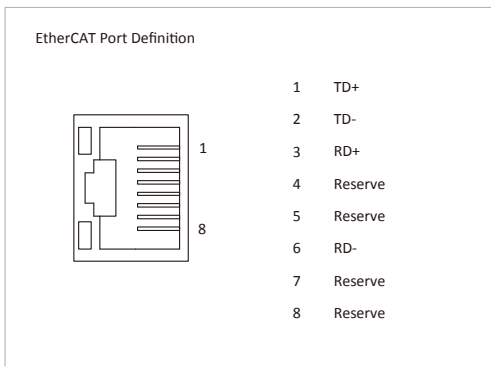
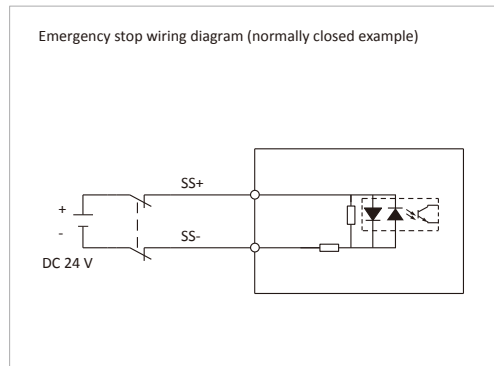
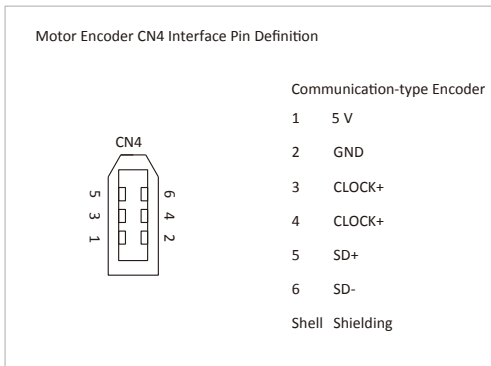
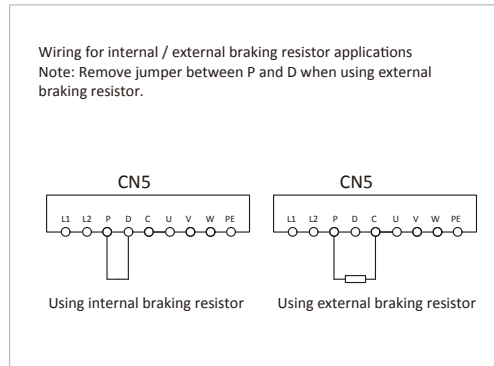
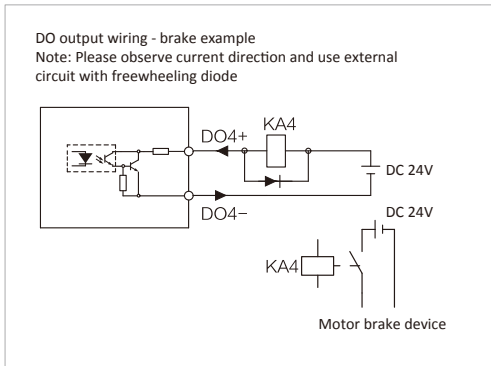
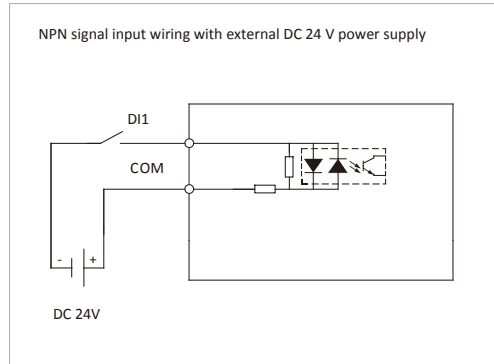
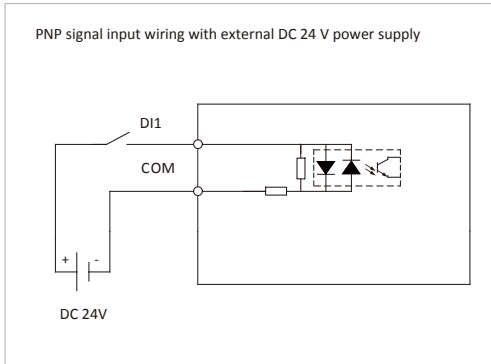

Driver accessories

Configuration software (ELCO Servo Tool)	
Model	KST-SW.02
Description	SA / SC Series Servo System Configuration Software

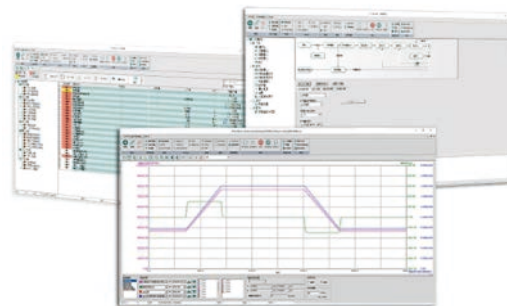

Configuration cable	
Model	KSL-M13-030
Description	SA / SC Series MiniUSB Configuration Cable (3 m)

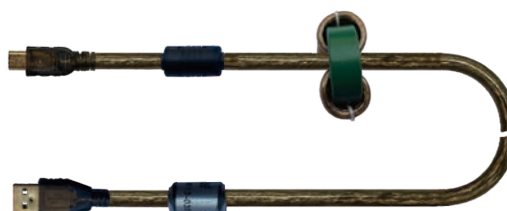

Terminal block set	
Model	Description
KSA-TB11.01	SC Series A1/A2 Specification Terminal Block Set
KSA-TB12.01	SC Series A3 Specification Terminal Block Set
KSA-TB13.01	SC Series B1/B2 Specification Terminal Block Set
KSA-TB14.01	SC Series B3 Specification Terminal Block Set
KSA-TB17.01	SA Series C1/C2 Specification Terminal Block Set
KSA-TB17.02	SA Series C1/C2 Specification Terminal Block Set with STO



Terminal assembly	
Model	Description
KSL-CAT-003.01	EtherCAT Communication Cable 0.3M
KSL-CAT-005.01	EtherCAT Communication Cable 0.5M
KSL-CAT-010.01	EtherCAT Communication Cable 1M
KSL-CAT-030.01	EtherCAT Communication Cable 3M
KSL-CAT-050.01	EtherCAT Communication Cable 5M

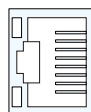

EtherCAT Pin Definition			
1	TD+	5	Reserve
2	TD-	6	RD-
3	RD+	7	Reserve
4	Reserve	8	Reserve

Note: Standard CAT5e cable is used. Please consult for special requirements.

Brake resistor

Braking Resistor Selection Table

Driver model	Matching Motor power	Internal braking Resistor of the driver	Recommended external braking resistor*				
			Model	Power	Resistance value	Maximum braking energy Ec (J) that the driver capacitor can absorb	
1R8MS	200 W	No	RXLG-100W 50RJ	100 W	50 Ω	20	
2R8MS	400 W		RXLG-100W 50RJ	100 W	50 Ω		
3R5MS	600 W		RXLG-200W 50RJ	200 W	50 Ω		
4R2MS	750 W	40 W; 80 Ω	RXLG-200W 50RJ	200 W	50 Ω	34	
060HS	850 W		RXLG-200W 25RJ	200 W	25 Ω		
	1.0 kW		RXLG-200W 25RJ	200 W	25 Ω		
100MS	1.0 kW		RXLG-200W 25RJ	200 W	25 Ω		
	1.5 kW	60 W; 40 Ω	RXLG-400W 25RJ	400 W	25 Ω		
120MS	1.0 kW		RXLG-200W 25RJ	200 W	25 Ω		
	1.3 kW		RXLG-400W 25RJ	400 W	25 Ω		
120HS	1.5 kW		RXLG-400W 25RJ	400 W	25 Ω		
	1.8 kW		RXLG-400W 25RJ	400 W	25 Ω		
140MS	2.0 kW	100 W; 20 Ω	RXLG-400W 25RJ	400 W	25 Ω	60	
	2.5 kW		RXLG-500W 25RJ	500 W	25 Ω		
	2.6 kW		RXLG-500W 25RJ	500 W	25 Ω		
5R4MT	3.0 kW		RXLG-800W 25RJ	800 W	25 Ω	130	
	1.0 kW		RXLG-200W 50RJ	200 W	50 Ω		
6R8MT	2.0 kW		RXLG-400W 50RJ	400 W	50 Ω		
	1.3 kW		RXLG-400W 50RJ	400 W	50 Ω		
	1.5 kW		RXLG-400W 50RJ	400 W	50 Ω		
	2.0 kW	No	RXLG-400W 50RJ	400 W	50 Ω		
8R3MT	2.5 kW		RXLG-500W 50RJ	500 W	50 Ω		
	3.0 kW		RXLG-800W 50RJ	800 W	50 Ω		
	1.8 kW		RXLG-400W 50RJ	400 W	50 Ω		
	2.5 kW		RXLG-500W 50RJ	500 W	50 Ω		
100MT	3.5 kW		RXLG-800W 50RJ	800 W	50 Ω		156
	4.0 kW	No	RXLG-800W 50RJ	800 W	50 Ω		
	2.3 kW		RXLG-500W 50RJ	500 W	50 Ω		
5.0 kW		RXLG-1000W 50RJ	1000 W	50 Ω			
120MT	6.0 kW		RXLG-1500W 50RJ	1500 W	50 Ω	156	
140MT	7.0 kW	No	RXLG-1500W 50RJ	1500 W	50 Ω		
210MT	8.3 kW		RXLG-2000W 50RJ	2000 W	50 Ω		
250MT	10.0 kW	No	RXLG-2000W 25RJ	2000 W	25 Ω	203	
340MT	11.0 kW		RXLG-2500W 25RJ	2500 W	25 Ω	270	
	13.2 kW	No	RXLG-3000W 25RJ	3000 W	25 Ω		
	14.7 kW		RXLG-3000W 25RJ	3000 W	25 Ω		
	15.0 kW		RXLG-3000W 25RJ	3000 W	25 Ω		

* Note:

The braking resistor power in the selection table is the recommended power. You can choose the appropriate power on site according to your needs.

The external braking resistor needs to be purchased by the user themselves.

Brake resistor

Naming rule for brake resistors

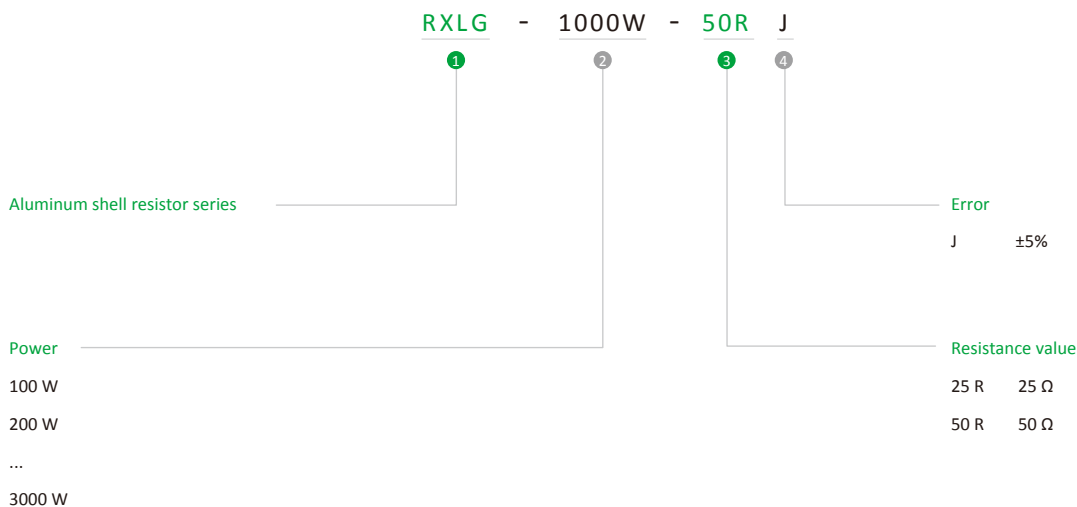

Dimension drawing

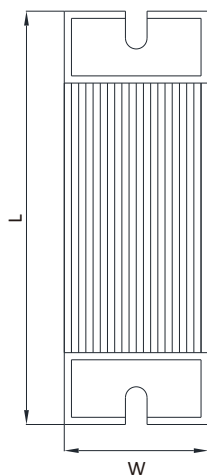
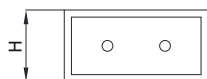

Brake resistor schematic diagram

No.	Brake resistor model	Specification dimensions: W × H × D (mm)
1	RXLG-100W 50RJ	115 × 40 × 20
2	RXLG-200W 50RJ / RXLG-200W 25RJ	165 × 60 × 30
3	RXLG-400W 50RJ / RXLG-400W 25RJ	265 × 60 × 30
4	RXLG-500W 50RJ / RXLG-500W 25RJ	285 × 60 × 30
5	RXLG-800W 50RJ / RXLG-800W 25RJ	335 × 60 × 30
6	RXLG-1000W 50RJ	300 × 100 × 50
7	RXLG-1500W 25RJ / RXLG-1500W 50RJ	400 × 100 × 50
8	RXLG-2000W 25RJ / RXLG-2000W 50RJ	450 × 100 × 50
9	RXLG-2500W 25RJ	485 × 100 × 50
10	RXLG-3000W 25RJ	550 × 100 × 50



ELCO Industrie Automation GmbH

Benzstrasse 7
71720 Oberstenfeld
Deutschland
E-Mail: info@elco-automation.de
www.elco-automation.de

Elco Automation LLC

1097 Highway 101 South, Suite D-3
Greer, South Carolina 29651 - USA
Office Phone: +1 864-581-7431
E-Mail: infousa@elcoautomation.com
www.elcoautomation.com

TIANJIN ELCO AUTOMATION CO., LTD

No.12, 4th XEDA Branch Road
Xiqing Economic-Technological Development Area
Tianjin 300385, P. R. China
E-Mail: info@elco.cn
www.elco-holding.com.cn