



Description

Topydic series small shaft incremental encoder-EV40A delivers outstanding performance in mechanical shock-resistance and can withstand higher axial and radial loads to suit various industrial environments. Its special position of cabling fits to the limited installation space. Combining advanced signal processing technology with multiple types of electrical output, EV40A are capable of matching various upper control computers.

Features

- Stainless steel shaft ensures safety and stability in operation
- Optional types of flange connection offers more flexibility
- Metal casting housing for greater shock resistance
- Side cabling design greatly saves the installation space and simplifies wiring
- Reverse connection protection; short circuit protection

Mechanical Parameters

Shaft diameter	Ø 6g6 mm
Protection class	IP66 standard, IP67 optional
Max. speed / minute	6000 rpm
Max. load capacity of the shaft	60 N axial, 100 N radial
Shock resistance	50 G/11 ms
Vibration resistance	10 G 10 ... 2000 Hz
Bearing life	10 ⁹ revolution
Moment of inertia	1.9 × 10 ⁻⁶ kgm ²
Starting torque	< 0.08 Nm
Body material	AL-alloy
Housing material	Zn-alloy
Operating temperature	-20 ... +85 °C
Storage temperature	-25 ... +100 °C
Relative humidity / condensation	90%, condensation not permitted
Weight	110 g

Regular resolution: 10, 20, 30, 40, 50, 60, 70, 80, 90, 100, 200, 300, 360, 400, 500, 512, 600, 800, 1000, 1024, 2000, 4000, 2500, 5000, 2048

Attention: the products with above resolutions are available from stock, others on request.

Topydic Small Shaft Incremental Encoder EV40A

Electrical Parameters

Output circuit	RS422	Push-pull
Resolution	Max. 5000 ppr	Max. 5000 ppr
Supply voltage	5±0.25 or 10 ... 30 V DC	10 ... 30 V DC
Power consumption (no load)	≤ 80 mA	≤ 100 mA
Permissible load (channel)	± 50 mA	± 30 mA
Pulse frequency	Max. 800 kHz	Max. 800 kHz
Signal level high	Min. 3.4 V	Min. $U_b - 1.8$ V
Signal level low	Max. 0.4 V	Max. 2.0 V
Rise time T_r	Max. 200 ns	Max. 1 μ s
Fall time T_f	Max. 200 ns	Max. 1 μ s

Terminal Configuration

Signal	0 V	+U _B	A	\bar{A}	B	\bar{B}	Z	\bar{Z}	Shield
Color	WH	BN	GN	YE	GY	PK	BU	RD	\perp
Pin	10	12	5	6	8	1	3	4	PH

Dimensions (mm)

EV40A

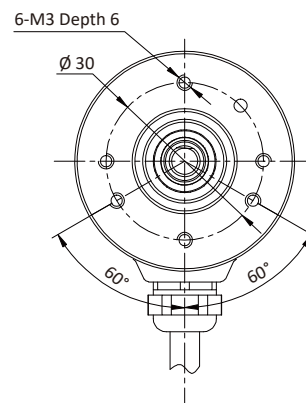
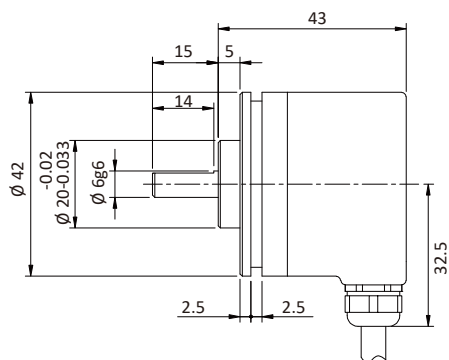

Topydic Small Shaft Incremental Encoder EV40A

Dimensions (mm)

EV40B

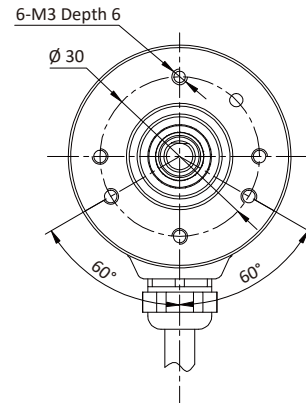
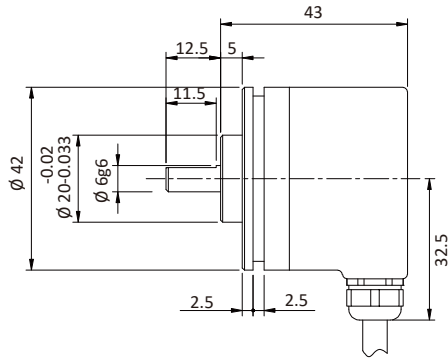

EV40C

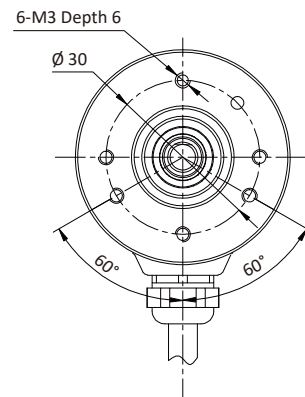
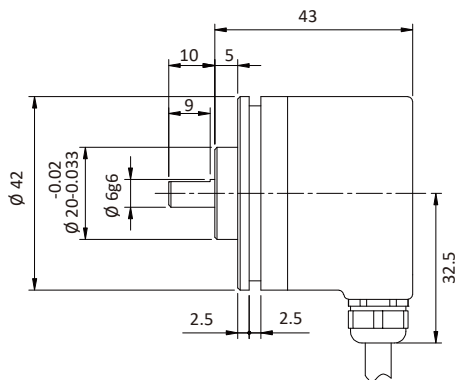

EV40A side pre-wired cable

