

EAM58-ECND

ARTICLE PROPERTIES

TYPE	EtherCAT interface absolute multiturn encoder
SIZE	Ø 58

TECHNICAL DATA

SHAFT DIAMETER	58B: Ø 6g6 mm 58C: Ø 10g6 mm	STARTING TORQUE	< 0.05 N·m
HOLLOW SHAFT DIAMETER	58W: Ø 8H7 / Ø 10H7 / Ø 12H7 / Ø 15H7 mm	BODY MATERIAL	Aluminum
SPEED	6000 rpm	HOUSING MATERIAL	Aluminum
BEARING LIFE	10 ⁹ revolution	FLANGE MATERIAL	Aluminum
MOMENT OF INERTIA	1.8 x 10 ⁻⁶ kgm ²	WEIGHT	600 g

ENVIRONMENTAL CONDITIONS

PROTECTION CLASS	IP65	OPERATING TEMPERATURE	-40 ... +80 °C
MAX LOAD CAPACITY OF THE SHAFT	80 N axial, 160 N radial	STORAGE TEMPERATURE	-45 ... +85 °C
SHOCK RESISTANCE (EN 60068-2-27)	50 g, 11 ms	RELATIVE HUMIDITY / CONDENSATION	90%, condensation not permitted
VIBRATION RESISTANCE (EN 60068-2-6)	10 g, 10 ... 2000 Hz		

ELECTRICAL PARAMETERS

INTERFACE	EtherCAT	MAX. BUS RATE	100 Mbits/s
PROFILE	CoE (CANopen over EtherCAT, DS-301 + DS-406)	INTERFACE CYCLE TIME	≥ 62.5 µs
PROGRAMMING FUNCTIONS	Resolution, preset, counting direction	CODE	Binary
SUPPLY VOLTAGE	10 ... 30 V DC	MAX. NUMBER OF LAPS	4096 (12 bits)
CURRENT CONSUMPTION (WITHOUT LOAD)	200 mA	MAX. RESOLUTION	8192 (13 bits)
POWER CONSUMPTION	≤ 2.5 W		

STANDARDS AND DIRECTIVES

LOW-VOLTAGE SWITCHGEAR AND CONTROLGEAR	EN IEC 61000-6-2 EN IEC 61000-6-4
---	--------------------------------------

APPROVALS



EAM58-ECND

TERMINAL ASSIGNMENT

Function	M12 connector						
Bus Port 1	Signal	Transmit data+	Receive data+	Transmit data-	Receive data-		Bus Port 1
	Abbreviation	TxD+	RxD+	TxD-	RxD-		
	Pin number	1	2	3	4	D coded	
Power Supply	Signal	Voltage+	-	Voltage-	-		Power Supply
	Abbreviation	+V	-	0 V	-		
	Pin number	1	2	3	4	A coded	
Bus Port 2	Signal	Transmit data+	Receive data+	Transmit data-	Receive data-		Bus Port 2
	Abbreviation	TxD+	RxD+	TxD-	RxD-		
	Pin number	1	2	3	4	D coded	

DIMENSIONS (mm)

EAM58B

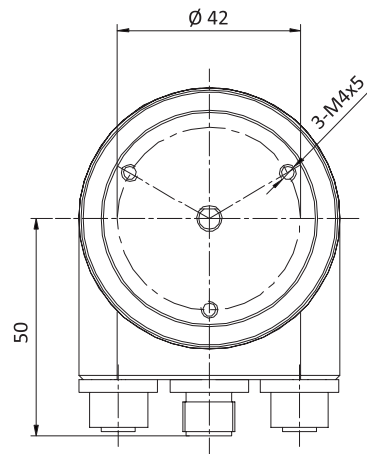
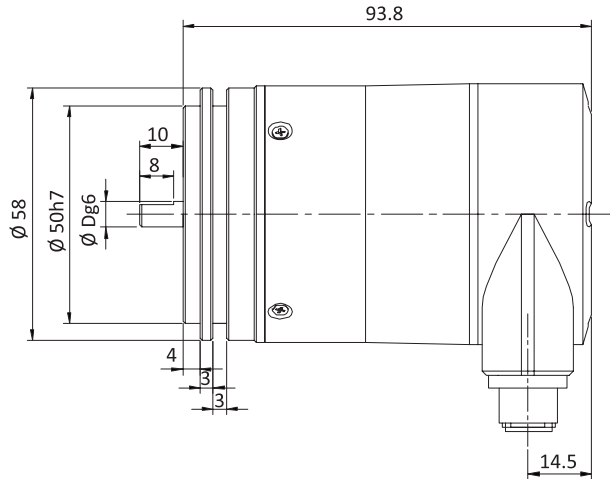

EAM58-ECND

DIMENSIONS (mm)

EAM58C

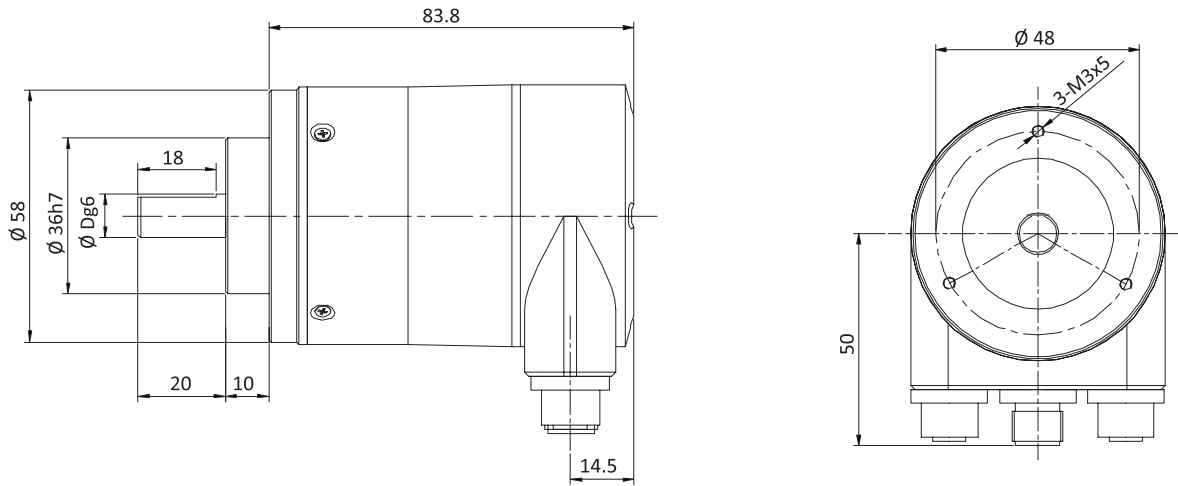

EAM58W

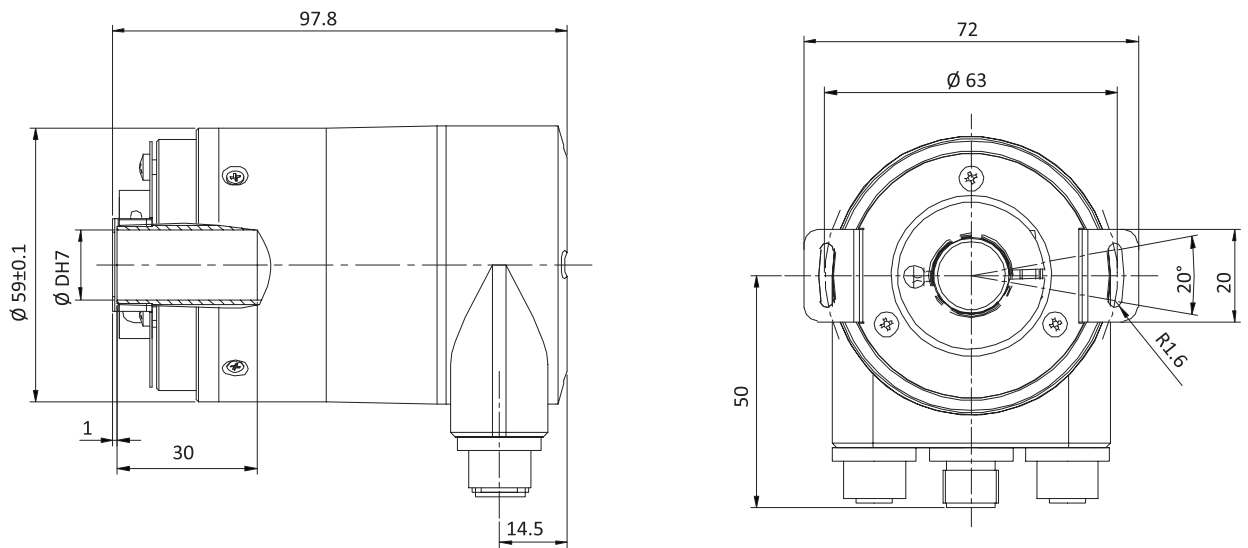

EAM58-ECND

ORDER CODE

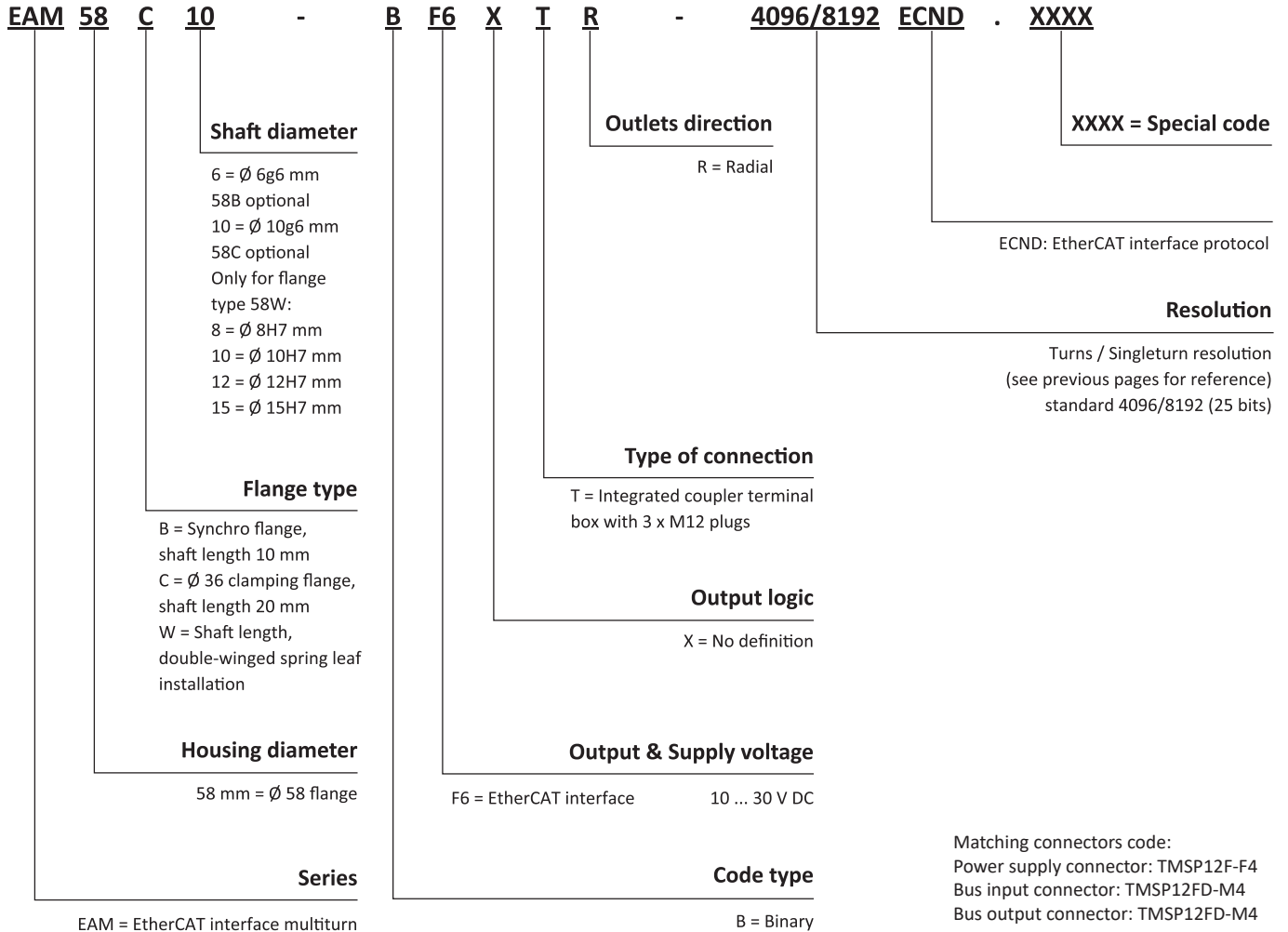

EAM58-ECND

SALES AND SERVICE

Tianjin Elco Automation Co., Ltd

No. 12, 4th XEDA Branch Road
Xiqing Economic-Technological Development Area
Tianjin 300385, P.R. China
Office Phone: 022 23788282
E-Mail: info@elco.cn
www.elco-holding.com.cn

Elco Industrie Automation GmbH

Benzstrasse 7
71720 Oberstenfeld,
Deutschland
Office Phone: +49 7062 / 6599-260
E-Mail: info@elco-automation.de
www.elco-automation.de

Elco Automation LLC

1097 Highway 101 South, Suite D-3 Greer
South Carolina 29651, USA
Office Phone: +1 864-581-7431
E-Mail: infousa@elcoautomation.com
www.elcoautomation.com

Elco Industrial Automation Pvt Ltd.

No 80, 1st Main, 2nd Cross, Royal Enclave,
Sidedahalli, Nagasandra Bangalore 560073, India
Office Phone: +91-7259931777
E-Mail: info@elcoautomation.in
www.elcoautomation.com

Elco Automation Korea Ltd.

706, 17 Daehak 4-ro, Yeongtong-gu, Suwon-si,
Gyeonggi-do, Republic of Korea, 16226
Office Phone: +82-31-216-7890
E-Mail: sales@elcoautomation.co.kr
www.elcoautomation.com