

EAM58-CAND

ARTICLE PROPERTIES

TYPE	CANopen Interface Absolute Multiturn Encoder
SIZE	Ø 58

TECHNICAL DATA

SHAFT DIAMETER	Ø 6g6 / Ø 10g6 mm	STARTING TORQUE	< 0.05 N·m
HOLLOW SHAFT DIAMETER	Ø 10H7 / Ø 12H7 / Ø 15H7 mm	BODY MATERIAL	Aluminum
SPEED	3000 rpm	HOUSING MATERIAL	Aluminum
BEARING LIFE	10 ⁹ revolution	FLANGE MATERIAL	Aluminum
MOMENT OF INERTIA	1.8 x 10 ⁻⁶ kgm ²	WEIGHT	800 g

ENVIRONMENTAL CONDITIONS

PROTECTION CLASS	IP65	OPERATING TEMPERATURE	-40 ... +80 °C
MAX LOAD CAPACITY OF THE SHAFT	80 N axial, 160 N radial	STORAGE TEMPERATURE	-45 ... +85 °C
SHOCK RESISTANCE (EN 60068-2-27)	50 g, 11 ms	RELATIVE HUMIDITY / CONDENSATION	90%, condensation not permitted
VIBRATION RESISTANCE (EN 60068-2-6)	10 g, 10 ... 2000 Hz		

ELECTRICAL PARAMETERS

SUPPLY VOLTAGE	10 ... 30 V DC	PROTOCOL	CANopen Profile DSP 406 with additional function
CURRENT	Max. 0.29 A	BAUD RATE	Based 250 K (Pre-factory setting) CAN DNET 125 / 250 / 500 kBit/son actual resolution
LINEARITY	±1/2 LSB (12 bit) ±1 LSB (13 bit)	ADD.	Add. set: 1 ... 99 32 (Pre-factory setting)
CODE	Binary	TERMINATION RESISTORS	120 Ω
INTERFACE	CAN HIGH-Speed to ISO/DIS 11898, Basic and Full-CAN; CAN specification 2.0 B		

STANDARDS AND DIRECTIVES

LOW-VOLTAGE SWITCHGEAR AND CONTROLGEAR	EN IEC 61000-6-2 EN IEC 61000-6-4
---	--------------------------------------

EAM58-CAND

APPROVALS



TERMINAL ASSIGNMENT

Encoder ID and terminal switch diagram

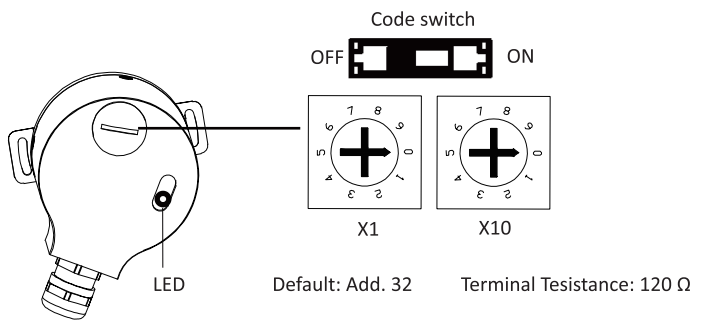

Signal	0 V	+Ub	CAN_H	CAN_L	Shield
Color	WH	BN	GN	GY	⊥

DIMENSIONS (mm)

EAM58B

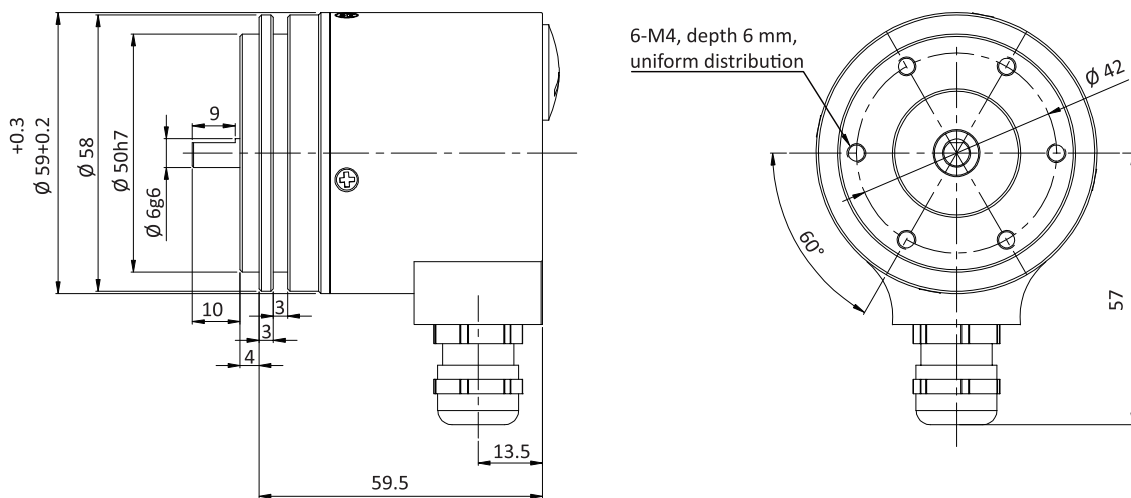

EAM58-CAND

DIMENSIONS (mm)

EAM58C

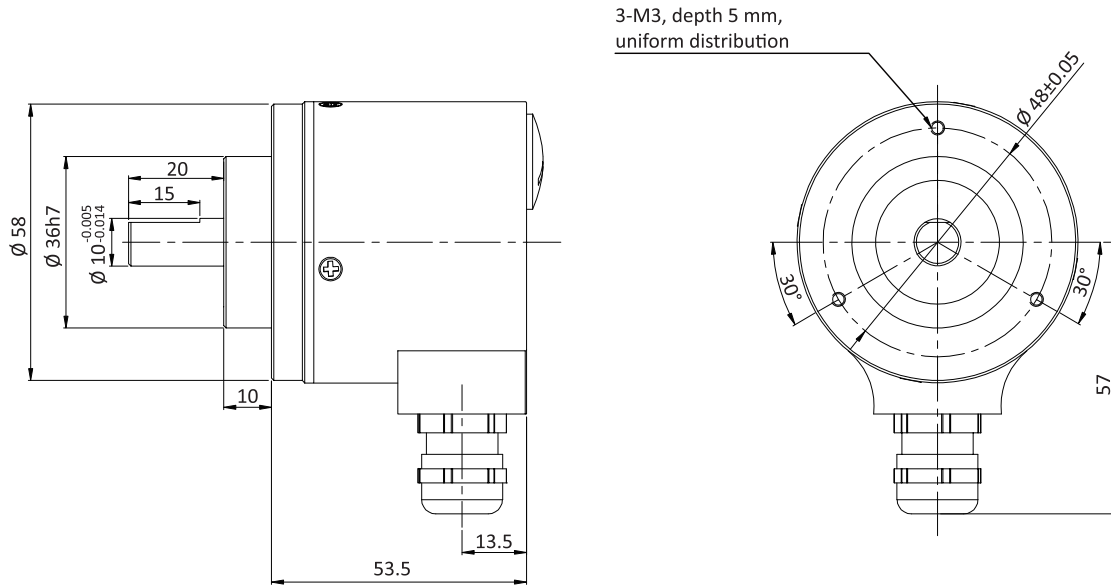

EAM58W

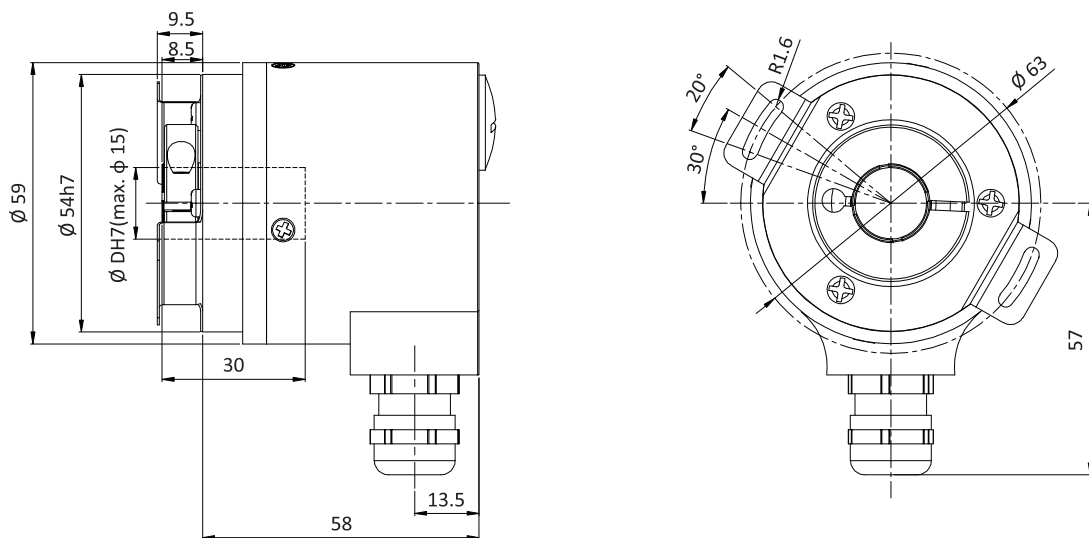

EAM58-CAND

ORDER CODE

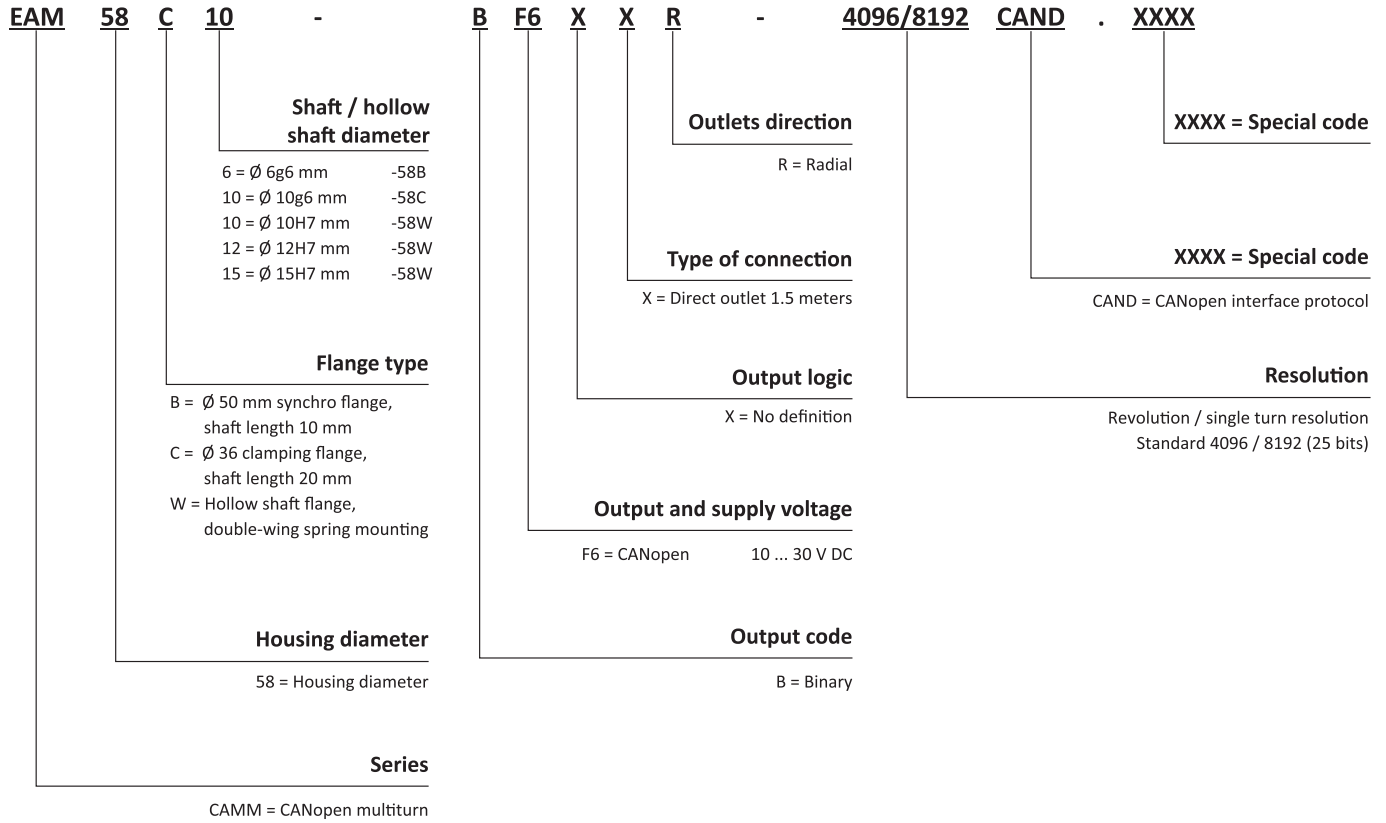

EAM58-CAND

SALES AND SERVICE

Tianjin Elco Automation Co., Ltd

No. 12, 4th XEDA Branch Road
Xiqing Economic-Technological Development Area
Tianjin 300385, P.R. China
Office Phone: 022 23788282
E-Mail: info@elco.cn
www.elco-holding.com.cn

Elco Industrie Automation GmbH

Benzstrasse 7
71720 Oberstenfeld,
Deutschland
Office Phone: +49 7062 / 6599-260
E-Mail: info@elco-automation.de
www.elco-automation.de

Elco Automation LLC

1097 Highway 101 South, Suite D-3 Greer
South Carolina 29651, USA
Office Phone: +1 864-581-7431
E-Mail: infousa@elcoautomation.com
www.elcoautomation.com

Elco Industrial Automation Pvt Ltd.

No 80, 1st Main, 2nd Cross, Royal Enclave,
Sidedahalli, Nagasandra Bangalore 560073, India
Office Phone: +91-7259931777
E-Mail: info@elcoautomation.in
www.elcoautomation.com

Elco Automation Korea Ltd.

706, 17 Daehak 4-ro, Yeongtong-gu, Suwon-si,
Gyeonggi-do, Republic of Korea, 16226
Office Phone: +82-31-216-7890
E-Mail: sales@elcoautomation.co.kr
www.elcoautomation.com