

## FX20-SCM-BB00

## ARTICLE PROPERTIES

|                     |  |                          |                         |
|---------------------|--|--------------------------|-------------------------|
| <b>PRODUCT TYPE</b> | FX20 series modular I/O system serial communication module   | <b>PRODUCT GROUP</b>     | IP20 modular I/O system |
| <b>DESCRIPTION</b>  | FX20-submodul 2-channel communication module, RS-485 / RS-422 / RS-232, 24 V DC, IP20, DIN rail installation | <b>PU</b>                | 1 pcs                   |
|                     |  | <b>COUNTRY OF ORIGIN</b> | CN                      |

## TECHNICAL DATA

|                               |  |                                  |  |
|-------------------------------|--|----------------------------------|--|
| <b>NUMBER OF CHANNEL</b>      | 2  | <b>CHECK BIT</b>                 | No checksum, odd or even checksum can be set   |
| <b>INTERFACE TYPE</b>         | Terminal type  | <b>TIMEOUT TIME</b>              | Default 100 ms, 2 ... 65535 ms can be set      |
| <b>COMMUNICATION METHODS</b>  | RS485: 2-wire, half duplex<br>RS422: 4-wire, full duplex<br>RS232: 2-wire, half duplex | <b>SLAVE STATION NUMBER</b>      | 1 ... 247                                      |
| <b>OPERATING MODE</b>         | MODBUS master station, slave station, free transparent transmission                    | <b>COMMUNICATION DISTANCE</b>    | RS485 / RS422: Max. 30 m<br>RS232: Max. 10 m   |
| <b>COMMUNICATION PROTOCOL</b> | MODBUS RTU, MODBUS ASCII, free port  | <b>PROCESS DATA LENGTH</b>       | Received data: 21 bytes<br>Sent data: 15 bytes |
| <b>BAUD RATE</b>              | Default 115200 bps, 300 ... 921600 bps can be set                                      | <b>OPERATING VOLTAGE</b>         | 24 V DC  |
| <b>DATA BITS</b>              | 7 bit or 8 bit   | <b>CURRENT CONSUMPTION (5 V)</b> | 60 mA  |
| <b>STOP BIT</b>               | 1 or 2 stop bits can be set  | <b>FAULT DIAGNOSIS METHOD</b>    | LED, communication message                     |

## CONNECTION DATA

|                        |   |                         |                                    |
|------------------------|---|-------------------------|------------------------------------|
| <b>WIRE CONNECTION</b> | Plug-in terminal block  | <b>STRIPPED LENGTHS</b> | 8 ... 10 mm,<br>0.315 ... 0.394 in |
| <b>CROSS SECTION</b>   | 0.08 mm <sup>2</sup> ... 2.5 mm <sup>2</sup> ,<br>AWG 28 ... 14 |                         |                                    |

## FX20-SCM-BB00

## ENVIRONMENTAL REQUIREMENTS

|                            |                              |  |                            |
|----------------------------|------------------------------|--|----------------------------|
| <b>PROTECTION CLASS</b>    | IP20                         | <b>ELECTRICAL FAST TRANSIENT (EFT)</b> | Level A, per IEC 61000-4-4 |
| <b>MOUNTING TYPE</b>       | DIN-35 mm rail               | <b>ELECTRO-STATIC DISCHARGE (ESD)</b>  | Level A, per IEC 61000-4-2 |
| <b>AMBIENT TEMPERATURE</b> | -5 ... +60 °C                | <b>SURGE TEST</b>                      | Level A, per IEC 61000-4-5 |
| <b>STORAGE TEMPERATURE</b> | -25 ... +70 °C               | <b>VIBRATION RESISTANCE</b>            | 4 g, per IEC 60068-2-6     |
| <b>RELATIVE HUMIDITY</b>   | 95%, non-condensing          | <b>SHOCK RESISTANCE</b>                | 15 g, per IEC 60068-2-27   |
| <b>OPERATING ALTITUDE</b>  | 0 ... 2000 m / 0 ... 6562 ft | <b>EU ROHS COMPLIANCE STATUS</b>       | Yes                        |
| <b>POLLUTION DEGREE</b>    | 2, per IEC 61131-2           | <b>MATERIAL COMPLIANCE</b>             | Compliant with REACH       |

## GENERAL DATA

|                         |            |                               |                      |
|-------------------------|------------|-------------------------------|----------------------|
| <b>HOUSING MATERIAL</b> | PPE        | <b>DIMENSIONS (H X W X D)</b> | 110.6 x 15 x 78.4 mm |
| <b>WEIGHT</b>           | 63 g       | <b>APPROVALS</b>              | CE                   |
| <b>COLOR</b>            | Light gray |                               |                      |

## APPROVALS



FX20-SCM-BB00

DIMENSIONS

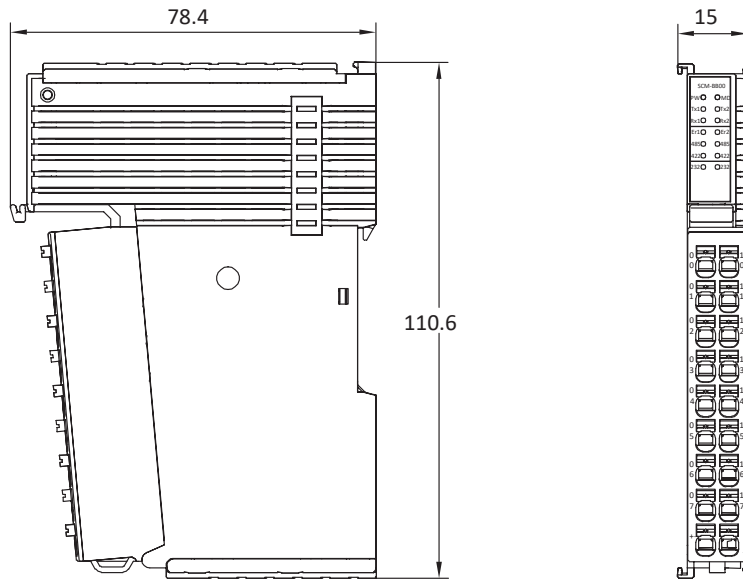

WIRING DIAGRAM

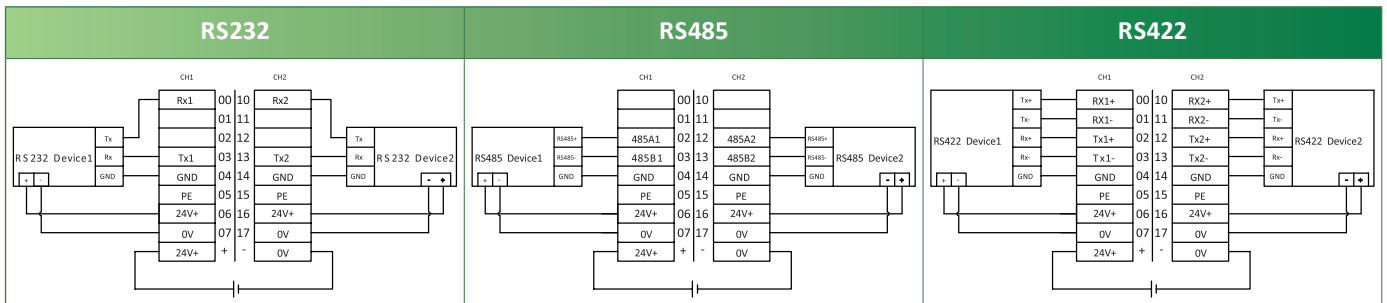

## FX20-SCM-BB00

---

### SALES AND SERVICE

**Tianjin Elco Automation Co., Ltd**

No. 12, 4th XEDA Branch Road  
Xiqing Economic-Technological Development Area  
Tianjin 300385, P.R. China  
Office Phone: 022 23788282  
E-Mail: [info@elco.cn](mailto:info@elco.cn)  
[www.elco-holding.com.cn](http://www.elco-holding.com.cn)

**Elco Industrie Automation GmbH**

Benzstrasse 7  
71720 Oberstenfeld,  
Deutschland  
Office Phone: +49 7062 / 6599-260  
E-Mail: [info@elco-automation.de](mailto:info@elco-automation.de)  
[www.elco-automation.de](http://www.elco-automation.de)

**Elco Automation LLC**

1097 Highway 101 South, Suite D-3 Greer  
South Carolina 29651, USA  
Office Phone: +1 864-581-7431  
E-Mail: [infousa@elcoautomation.com](mailto:infousa@elcoautomation.com)  
[www.elcoautomation.com](http://www.elcoautomation.com)

**Elco Industrial Automation Pvt Ltd.**

No 80, 1<sup>st</sup> Main, 2<sup>nd</sup> Cross, Royal Enclave,  
Sidedahalli, Nagasandra Bangalore 560073, India  
Office Phone: +91-7259931777  
E-Mail: [info@elcoautomation.in](mailto:info@elcoautomation.in)  
[www.elcoautomation.com](http://www.elcoautomation.com)

**Elco Automation Korea Ltd.**

706, 17 Daehak 4-ro, Yeongtong-gu, Suwon-si,  
Gyeonggi-do, Republic of Korea, 16226  
Office Phone: +82-31-216-7890  
E-Mail: [sales@elcoautomation.co.kr](mailto:sales@elcoautomation.co.kr)  
[www.elcoautomation.com](http://www.elcoautomation.com)