

FX20-AI-BD90

ARTICLE PROPERTIES

PRODUCT TYPE	FX20 series modular I/O system analog input modules	PRODUCT GROUP	IP20 modular I/O system
DESCRIPTION	FX20-submodule 4-channel TC measurement, 24 V DC, IP20, DIN rail installation	PU	1 pcs
		COUNTRY OF ORIGIN	CN

TECHNICAL DATA

NUMBER OF ANALOG INPUTS	4	MEASUREMENT ACCURACY	Within 2 °C
INPUT TYPE	Thermocouples: J, K, T, N, E types	OPERATING VOLTAGE	24 V DC
INPUT RESOLUTION	16 bits	CURRENT CONSUMPTION (5 V)	60 mA
CONVERTING TIME(TYP.)	320 ms	PROCESS DATA LENGTH	8 bytes
SENSITIVITY	0.1 °C	FAULT DIAGNOSIS METHOD	LED, communication message

CONNECTION DATA

WIRE CONNECTION	Plug-in terminal block	STRIPPED LENGTHS	8 ... 10 mm, 0.315 ... 0.394 in
CROSS SECTION	0.08 mm ² ... 2.5 mm ² , AWG 28 ... 14		

ENVIRONMENTAL REQUIREMENTS

PROTECTION CLASS	IP20	ELECTRICAL FAST TRANSIENT (EFT)	Level A, per IEC 61000-4-4
MOUNTING TYPE	DIN-35 mm rail	ELECTRO-STATIC DISCHARGE (ESD)	Level A, per IEC 61000-4-2
AMBIENT TEMPERATURE	-5 ... +60 °C	SURGE TEST	Level A, per IEC 61000-4-5
STORAGE TEMPERATURE	-25 ... +70 °C	VIBRATION RESISTANCE	4 g, per IEC 60068-2-6
RELATIVE HUMIDITY	95%, non-condensing	SHOCK RESISTANCE	15 g, per IEC 60068-2-27
OPERATING ALTITUDE	0 ... 2000 m / 0 ... 6562 ft	EU ROHS COMPLIANCE STATUS	Yes
POLLUTION DEGREE	2, per IEC 61131-2	MATERIAL COMPLIANCE	Compliant with REACH

GENERAL DATA

HOUSING MATERIAL	PPE	DIMENSIONS (H X W X D)	110.6 x 15 x 78.4 mm
WEIGHT	63 g	MTTF (25 °C)	196 years
COLOR	Light gray	APPROVALS	CE

FX20-AI-BD90

APPROVALS



DIMENSIONS

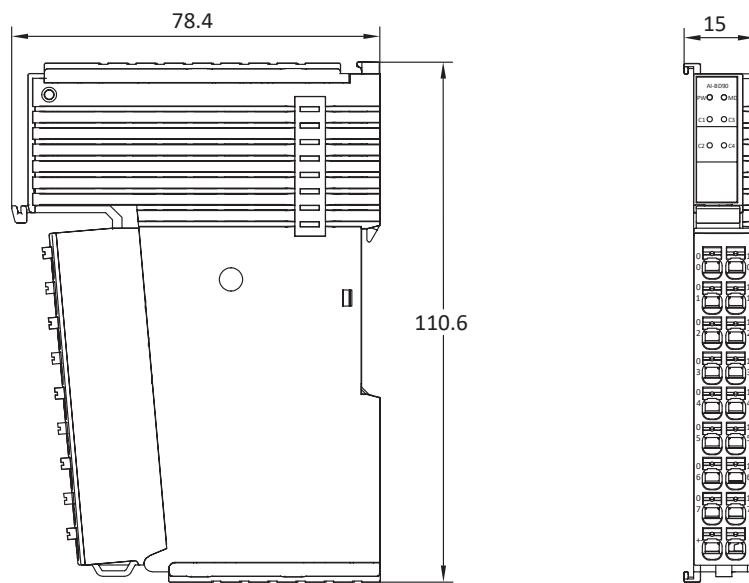

WIRING DIAGRAM

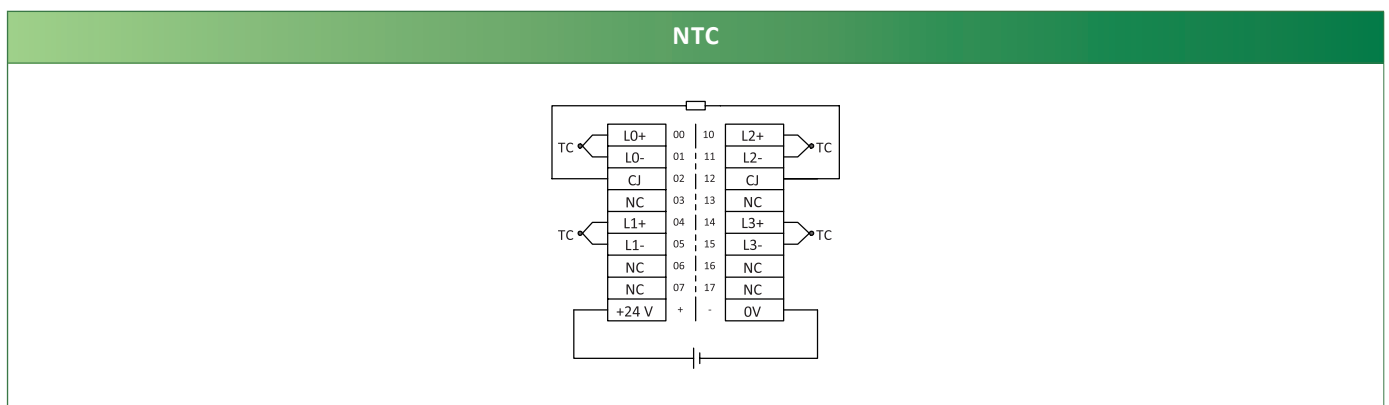

FX20-AI-BD90

SALES AND SERVICE**Tianjin Elco Automation Co., Ltd**

No. 12, 4th XEDA Branch Road
Xiqing Economic-Technological Development Area
Tianjin 300385, P.R. China
Office Phone: 022 23788282
E-Mail: info@elco.cn
www.elco-holding.com.cn

Elco Industrie Automation GmbH

Benzstrasse 7
71720 Oberstenfeld,
Deutschland
Office Phone: +49 7062 / 6599-260
E-Mail: info@elco-automation.de
www.elco-automation.de

Elco Automation LLC

1097 Highway 101 South, Suite D-3 Greer
South Carolina 29651, USA
Office Phone: +1 864-581-7431
E-Mail: infousa@elcoautomation.com
www.elcoautomation.com

Elco Industrial Automation Pvt Ltd.

No 80, 1st Main, 2nd Cross, Royal Enclave,
Sidedahalli, Nagasandra Bangalore 560073, India
Office Phone: +91-7259931777
E-Mail: info@elcoautomation.in
www.elcoautomation.com

Elco Automation Korea Ltd.

706, 17 Daehak 4-ro, Yeongtong-gu, Suwon-si,
Gyeonggi-do, Republic of Korea, 16226
Office Phone: +82-31-216-7890
E-Mail: sales@elcoautomation.co.kr
www.elcoautomation.com